

KERNBOHRER · SCHIENENBOHRER

ANNULAR CUTTERS · RAIL CUTTERS



- 1
- 2
- 3
- 4
- 5
- 6
- 7
- 8
- 9
- 10

2.6

KUNDENSERVICE | CUSTOMER SERVICE

KARNASCH PROFESSIONAL TOOLS[®]

info@karnasch.tools

+49 (0) 6203 - 40390

KARNASCH ONLINESHOP

JETZT FÜR SIE ONLINE!
NOW ONLINE FOR YOU!

<https://karnasch.tools>



ONLINE



ÜBERSICHT • OVERVIEW

Kernbohrer + Spiralbohrer · Annular cutters + twist drills

378-449

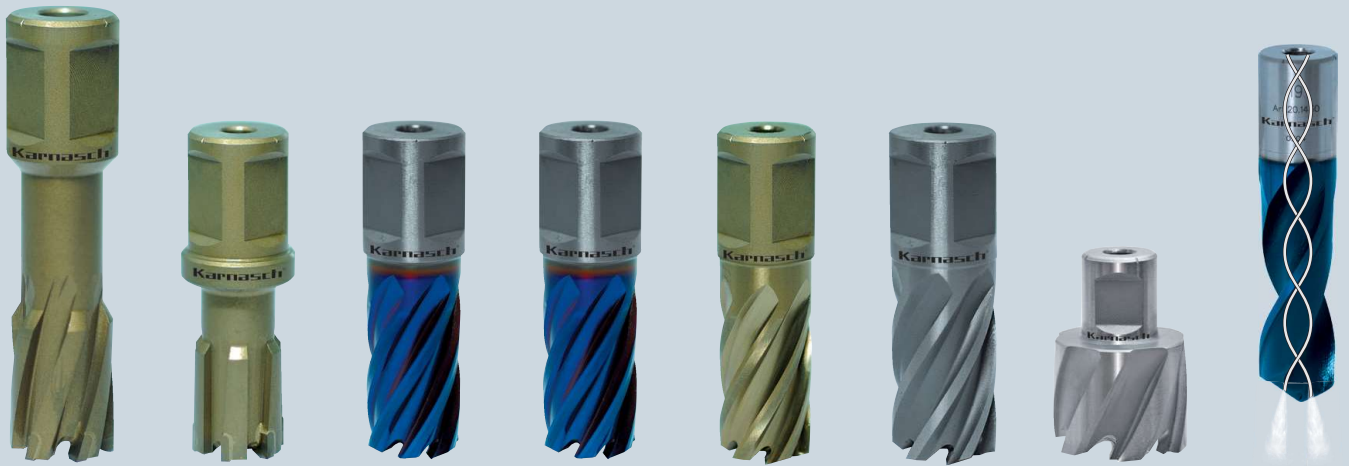

HARD-LINE /		HARDOX-LINE /		BLUE-DRILL LINE / PRO		BLUE-DRILL LINE /		GOLD-DRILL LINE /		SILVER-DRILL LINE /		MINI-LINE /		DRILL-LINE / PRO	
Weldon	380-389	Weldon	398-403	Weldon	404-409	Weldon	410-419	Weldon	420-429	Weldon	436-441	Weldon	442-443	Weldon	444-447
Nitto	452-467					Nitto	468-483	Nitto	484-505						
Fein	508-512					Fein	514-516	Fein	518-520						

Schienenbohrer · Rail cutters

526-540



RAIL-LINE / PRO		RAIL-LINE /		BLUE-DRILL LINE / PRO		SILVER-DRILL LINE /		DRILL-LINE / PRO		DRILL-LINE /	
	HM/T.C.T.		HM/T.C.T.		RAIL		RAIL		RAIL		RAIL
	522-525		526-529		530-533		534-537		538-539		540



Magnet-Kernbohrmaschine · Magnetic hole cutting machine

1197-1220



ÜBERSICHT • OVERVIEW

Zubehör · Sets · Displays · Ersatzteile / Accessories · Sets · Displays · Spare parts

541-552

Aufnahmehalter mit Morsekonus 2 / 3 / 4 / 5 und Reduzierhülsen 541-543

Tool holders with morse taper 2 / 3 / 4 / 5 and reduction sleeves

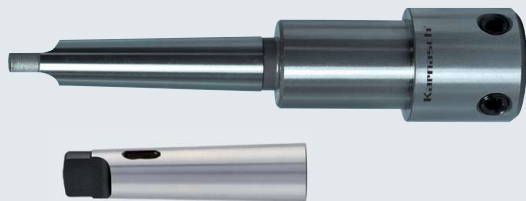

Kühlmittel-Druckflaschen 548

Coolant pressure bottles



Kegelsenker mit Weldonchaft 544/545

Countersinks with Weldon shank

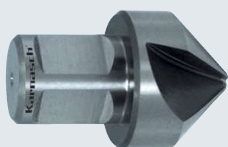

Magnetstab zur Entfernung der Bohrspäne 549

Magnetic stick for chip removal



Spiralbohradapter Weldon + Spiralbohrer Ø 2,5-12 mm 648

Twist drill adaptors Weldon + twist drills Ø 2,5-12 mm



Sets · Displays 553-582

Sets · Displays



Gewindeadapter Weldon + Gewindebohrer M 3 - M 30 649-650

Tapping adapter Weldon + taps M 3 - M 30



Vollhartmetall Gewindebohrer-Ausbohrer 652

Solid carbide drills to remove jammed taps



Adapter + passende Bohrfutter 548

Adapters + suitable drill chucks

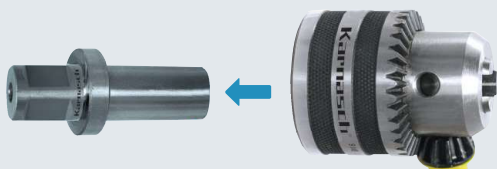

Ersatzteile 550-552

Spare parts

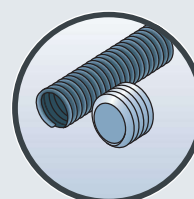

- 1
- 2
- 3
- 4
- 5
- 6
- 7
- 8
- 9
- 10

Welcher Kernbohrer / Bohrer passt auf welche Kernbohrmaschinen Which annular cutter / Twist drill fits which annular cutter machine

- 1 
- 2 
- 3 
- 4 
- 5 
- 6 
- 7 
- 8 
- 9 
- 10 

KERNBOHRER / BOHRER WELDONSCHAFT 19/32 MM
ANNULAR CUTTER / TWIST DRILL WELDON-SHANK 19/32 MM (3/4"+1.1/4")

 378-447

WELDON



Passende Kernbohrmaschinen von:
Matching machines made by:

KARNASCH · ALFRA-ROTABEST + ALFRA
ROTAQUICK · BDS · BDS KEYLESS ·
BEKTOP · BUX · CEMBRE · DUBUIS ·
ERICO · EUROBOOR · EVOLUTION · HALL
(POWERBOR) · HOUGEN · JANCY ·
MAGBROACH · MAGTRON · MAGNETOR ·
METALLKRAFT · PROMAG · ROTABROACH
· RUKO+RUKO EASY LOCK · UNIVERSAL
...



KERNBOHRER MIT NITTO / UNIVERSALSCHAFT 19 MM
ANNULAR CUTTER WITH NITTO / UNIVERSAL SHANK 19 MM (3/4")

 452-505

NITTO / UNIVERSAL



Passende Kernbohrmaschinen von Nitto:
Matching machines made by Nitto:

NITTO KOHKI "ONE TOUCH" TYPE:
WOJ 3200 · AO 5575 · WA 3500 · WA 5000 · QA 4000 · QA 6500

Passend auch für alle Maschinen mit Weldonschaft 19 mm (siehe oben).
Hierbei ist darauf zu achten, dass nur **eine** Spannfläche vorhanden ist.

Also matching all machines with Weldon shank 19 mm (3/4") (see above).
Observe that there is only **one** clamping face.

KERNBOHRER MIT FEIN QUICK-IN SCHAFT 18 MM / FEIN QUICK-IN MAX-SCHAFT 32 MM
ANNULAR CUTTER WITH FEIN QUICK-IN SHANK 18 MM / FEIN QUICK-IN MAX-SHANK 32 MM (1.1/4")

 508-520

FEIN QUICK-IN



Passende Kernbohrmaschinen von Fein:
Matching machines made by Fein:

FEIN TYPE: KBM 32 Q · KBM 50 Q · KBM 50 U · KBM 50 AUTO · KBM 65 U · KBM 80 QUICK-IN MAX

KERNBOHRER · SPIRALBOHRER MIT WELDONSCHAFT

ANNULAR CUTTERS · TWIST DRILLS WITH WELDON SHANK





Passende Kernbohrmaschinen von:
Matching machines made by:

KARNASCH · ALFRA-ROTABEST + ALFRA ROTAQUICK · BDS · BDS
KEYLESS · BEKTOP · BUX · CEMBRE · DUBUIS · ERICO · EUROBOOR ·
EVOLUTION · HALL (POWERBOR) · HOUGEN · JANCY ·
MAGBROACH · MAGTRON · MAGNETOR · METALLKRAFT · PROMAG ·
ROTABROACH · RUKO+RUKO EASY LOCK · UNIVERSAL ...





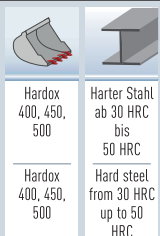









WELDON

- 1 
- 2 
- 3 
- 4 
- 5 
- 6 
- 7 
- 8 
- 9 
- 10 







Übersicht Kernbohrer Weldonschaft Overview annular cutters Weldon shank

TYPE	Ø	Beschreibung · Specification	Anwendung · Application
HARD-LINE	Ø 12-200 mm Ø 15/32-7.7/8"	<p>Kernbohrer Hartmetall-bestückt Die leistungsstärksten Kernbohrer in unserem Sortiment. Exzellente für alle Stähle bis 1400 N Festigkeit sowie für alle Edelstähle.</p> <p>Annular cutters carbide-tipped The most powerful annular cutters in our range. Excellent for all steels up to a strength of 1400 N and for all stainless steels.</p>	 <p>Stahl Edelstahl Grauguss Alu Kupfer, Messing, Zinn</p> <p>Steel Stainless Grey cast iron Alu Copper, brass, tin</p>
			380-397
HARD-LINE ZOLL / INCH	Ø 1/2-2.1/16"	<p>Der beste Kernbohrer zum Bohren in:</p> <ul style="list-style-type: none"> • Hardox 400, 450, 500 • Harte Stähle ab 30 HRC bis 50 HRC <p>Speziell entwickeltes Hartmetall sowie optimierte Geometrie ergeben exzellente Ergebnisse beim Bohren von HARDOX / HARTE STÄHLE (unbedingt Schnittparameter beachten).</p> <p>The best annular cutter for drilling in:</p> <ul style="list-style-type: none"> • Hardox 400, 450, 500 • Hard steels from 30 HRC up to 50 HRC <p>Specially developed carbide as well as optimized geometry results in excellent performance for drilling in HARDOX / HARD STEEL (absolutely observe cutting parameters).</p>	 <p>Hardox 400, 450, 500 Harder Stahl ab 30 HRC bis 50 HRC</p> <p>Hardox 400, 450, 500 Hard steel from 30 HRC up to 50 HRC</p>
			398-403
BLUE-DRILL LINE / PRO	Ø 12-36 mm Ø 15/32-1.27/64"	<p>Kernbohrer aus Pulverstahl + DURABLU- Beschichtung. Für schwierigste Zerspanungsprobleme. Gut für alle Stähle bis 1400 N Festigkeit sowie für alle Edelstähle.</p> <p>Annular cutters made of powder steel + DURABLU-coating. For the most difficult chipping problems. Good for all steels up to a strength of 1400 N and for all stainless steels.</p>	 <p>Stahl Edelstahl Grauguss Alu Kupfer, Messing, Zinn</p> <p>Steel Stainless Grey cast iron Alu Copper, brass, tin</p>
			404-409
BLUE-DRILL LINE	Ø 12-60 mm Ø 15/32-2.23/64"	<p>Kernbohrer aus HSS-XE Spezialstahl + DURABLU- Beschichtung. Der am meisten verwendete beschichtete Kernbohrer für alle Stähle bis 1100 N Festigkeit sowie für alle Edelstähle.</p> <p>Annular cutters made of HSS-XE special steel + DURABLU-coating. The most-often used coated annular cutter for all steels up to a strength of 1100 N and for all stainless steels.</p>	 <p>Stahl Edelstahl Grauguss Alu Kupfer, Messing, Zinn</p> <p>Steel Stainless Grey cast iron Alu Copper, brass, tin</p>
			410-419

Übersicht Kernbohrer Weldonschaft Overview annular cutters Weldon shank

TYPE	Ø	Beschreibung · Specification	Anwendung · Application	
GOLD-DRILL LINE	Ø 12-60 mm Ø 15/32-2.23/64"	Kernbohrer aus HSS-XE Spezialstahl + GOLD-TECH-Behandlung. Der am meisten verwendete nicht beschichtete Kernbohrer für alle Stähle bis 900 N Festigkeit. Auch noch für Edelstahl geeignet. Annular cutters made of HSS-XE special steel + GOLD-TECH treatment. The most-often used uncoated annular cutter for all steels up to a strength of 900 N. Still suitable for stainless steels.	 Stahl Steel  Edelstahl Stainless  Alu Alu  Kupfer, Messing, Zinn Copper, brass, tin  Hardox 400 Hardox 400  Hardox 450 Hardox 450	420-435
	Schnitttiefen Drill depths	30, 55, 80, 110 mm 1", 2", 3", 4"		
GOLD-DRILL LINE	Ø 7/16-2.1/16" ZOLL / INCH			
SILVER-DRILL LINE	Ø 12-60 mm Ø 15/32-2.23/64"	Kernbohrer aus HSS-XE Spezialstahl + 7 verschiedene Schneidgeometrien. Für alle Stähle bis 750 N Festigkeit. Annular cutters of HSS-XE special steel + 7 different cutting geometries. For all steels up to a strength of 750 N.	 Stahl Steel  Alu Alu  Kupfer, Messing, Zinn Copper, brass, tin  Hardox 400 Hardox 400	436-441
	Schnitttiefen Drill depths	25, 50 mm 1", 2"		
MINI-LINE	Ø 8-25 mm Ø 5/16-63/64"	Kernbohrer / Lochsagen Kombination. Für alle Stähle bis 900 N Festigkeit. Annular cutters / hole saw combination. For all steels up to a strength of 900 N.	 Stahl Steel  Edelstahl Stainless  Alu Alu  Kupfer, Messing, Zinn Copper, brass, tin  Hardox 400 Hardox 400	442-443
Schnitttiefen Drill depths	8 mm 5/16"			

Übersicht Spiralbohrer Weldonschaft · Overview twist drill Weldon shank

TYPE	Ø	Beschreibung · Specification	Anwendung · Application	
DRILL-LINE	Ø 4-32 mm Ø 5/32-1.17/64"	Spiralbohrer aus Pulverstahl / HSS-XE Stahl / HSS-Kobalt Stahl. Mit oder ohne Innenkühlung für Stähle bis 1400 N Festigkeit sowie für alle Edelstähle. Twist drills made of powder steel / HSS-XE-steel / HSS-Cobalt steel. With or without inner cooling for steels up to a strength of 1400 N and for all stainless steels.	 Stahl Steel  Edelstahl Stainless  Grauguss Grey cast iron  Alu Alu  Kupfer, Messing, Zinn Copper, brass, tin  Hardox 400 Hardox 400	444-449
Schnitttiefen Drill depths	30, 40, 50 mm 1", 1.1/2", 2"			



HARTMETALL-BESTÜCKTE KERNBOHRER CARBIDE-TIPPED ANNULAR CUTTERS

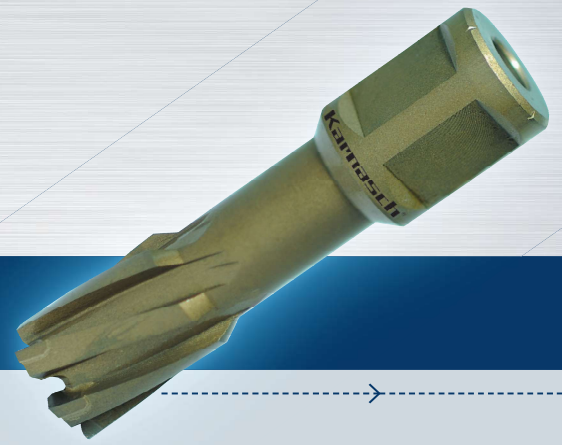

HARD-LINE

Der beste Kernbohrer ist grundsätzlich Hartmetall-bestückt.

Nur diese Bohrer bieten das optimale Preis-Leistungs-Verhältnis für nahezu alle Materialien. Neben der höchsten Standzeit in allen Stählen bieten nur Hartmetall-bestückte Kernbohrer:

- Bohren in Stähle bis 40 Rockwell (HRC)
- Bohren in alle Edelstähle
- Bohren in schwierigste Legierungen (Hardox/Inconel/Titan)
- Bohren hervorragend auch in weiche Werkstoffe wie Alu, Kupfer, Messing u.ä.

Mit Durchmessern von 12-200 mm in Schnitttiefen von 40 mm, 55 mm, 80 mm, 110 mm und 150 mm steht Ihnen weltweit das umfangreichste Lagerprogramm zur Verfügung.

The fact is: The best annular cutters are carbide tipped.

Only these drills offer the best value for money for almost all materials. Only carbide tipped annular cutters provide maximum cutting capacity in all kinds of steel:

- Drilling in hardened steel up to 40 Rockwell (HRC)
- Drilling in all sorts of stainless steel
- Drilling in most difficult alloys (Hardox/Inconel/Titan)
- Drilling also excellent in all non-ferrous metals such as alu, copper, brass

Available in diameter 12-200 mm. Available in drill depths 40 mm, 55 mm, 80 mm, 110 mm and 150 mm. Simply the world's largest stock range of carbide tipped annular cutters.

EIGENSCHAFTEN · PROPERTIES



Karnasch Hartmetall-bestückte Kernbohrer (HARD-LINE) werden mit konischer Spirale gefertigt für: Sauberen Spanfluss und höchste Zerspanleistung auch bei schwierigen Materialien.

Karnasch carbide tipped annular cutters (HARD-LINE) are made with a conical helix for: clean chip flow and highest cutting ability even with difficult materials.



Karnasch Hartmetall-bestückte Kernbohrer (HARD-LINE) werden ausschließlich mit Sandvik Hartmetallzähnen bestückt. Wir meinen: Nur das beste Hartmetall ist gut genug für Karnasch Kernbohrer.

Karnasch carbide tipped annular cutters (HARD-LINE) are exclusively equipped with Sandvik carbide teeth. Our opinion is: Only the best carbide is good enough for Karnasch annular cutters.

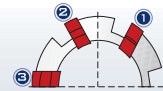

Karnasch Hartmetall-bestückte Kernbohrer (HARD-LINE) sind in einer aufwendigen Vor-Mittel-Nachsneider-Geometrie gefertigt. Dies ergibt: ratterfreies, ruhiges und leichtes Zerspanen mit höchsten Standzeiten.

Karnasch carbide tipped annular cutters (HARD-LINE) are made in an elaborate pre-/intermediate-/after-cutting geometry. This results in: clatter-free, silent and easy cutting with highest lifetimes.

ANWENDUNG · APPLICATION

Stahl	Edelstahl	Alu	Kupfer, Messing, Zinn	Kunststoffe GFK/CFK	Grauguss	Graphit	Hastelloy, Inconel, Nimonic, Exotische Materialien	Schienen
Steel	Stainless	Alu	Copper, brass, tin	Plastics GRP/CRP	Grey cast iron	Graphite	Hastelloy, Inconel, Nimonic, exotic materials	Rails
< 1400 N	> 900 N	> 10% Si						
✓	✓	✓	✓	✓	✓	✓	✓	✓

✓ OPTIMAL · OPTIMAL

✓ GUT · GOOD









✓ MÖGLICH · POSSIBLE

HARTMETALL-BESTÜCKTE KERNBOHRER CARBIDE-TIPPED ANNULAR CUTTERS

HARD-LINE

Schnitttiefe · Drill depths	Ø mm	Ø Zoll/Inch	Art. / Type	
 Weldon 40 mm 1.1/2" BEST SELLER	12-120	15/32-4.23/32"	20 1315 HARD-LINE / 40	382
 Weldon 55 mm 2" BEST SELLER	12-200	15/32-7.7/8"	20 1316 HARD-LINE / 55	384
 Weldon 80 mm 3"	14-120	35/64-4.23/32"	20 1650 HARD-LINE / 80	386
 Weldon 110 mm 4"	14-120	35/64-4.23/32"	20 1660 HARD-LINE / 110	388
 Weldon 150 mm 5.29/32"	18-60	45/64-2.23/64"	20 1665 HARD-LINE / 150	390
 Weldon 40 mm 1.1/2"	-	1/2-2.1/16"	20 1930 HARD-LINE ZOLL / INCH / 40	392
 Weldon 55 mm 2"	-	1/2-2.1/16"	20 1940 HARD-LINE ZOLL / INCH / 55	394
 Weldon 80 mm 3"	-	11/16-2.1/16"	20 1970 HARD-LINE ZOLL / INCH / 80	396

ZUBEHÖR · SETS · DISPLAYS · ERSATZTEILE / ACCESSORIES · SETS · DISPLAYS · SPARE PARTS

Aufnahmehalter mit Morsekonus 2 / 3 / 4 / 5 und Reduzierhülsen  541-543 Tool holders with morse taper 2 / 3 / 4 / 5 and reduction sleeves	Kühlmittel-Druckflaschen  548 Coolant pressure bottles
Kegelsenker mit Weldonschaft  544/545 Countersinks with Weldon shank	Magnetstab zur Entfernung der Bohrspäne  549 Magnetic stick for chip removal
Spiralbohradapter Weldon + Spiralbohrer Ø 2,5-12 mm  648 Twist drill adaptors Weldon + twist drills Ø 2,5-12 mm	Sets · Displays  553-582 Sets · Displays
Gewindeadapter Weldon + Gewindebohrer M 3 - M 30  649-650 Tapping adapter Weldon + taps M 3 - M 30	
Adapter + passende Bohrfutter  548 Adapters + suitable drill chucks	Ersatzteile  550-552 Spare parts



20 1315

HARD-LINE 40

Hartmetall-bestückter Kernbohrer, Weldonschaft, Nutzlänge 40 mm
Carbide-tipped annular cutter, Weldon shank, drill depth 40 mm | 1.1/2"



ANWENDUNG • APPLICATION

Stahl	Edelstahl	Grauguss	Alu	Kupfer, Messing, Zinn	Kunststoffe GFK/CFK	Hastelloy, Inconel, Exotische Materialien
Steel	Stainless	Grey cast iron	Alu	Copper, brass, tin	Plastics GRP/CRP	Hastelloy, Inconel, exotic materials
< 1400 N	> 900 N		> 10% Si			

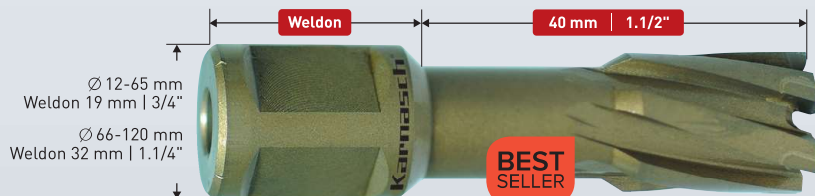

Bestseller – preisreduziert · Bestseller – price reduced

Art.	Ø mm	Ø Zoll Inch	Art.	Ø mm	Ø Zoll Inch	Art.	Ø mm	Ø Zoll Inch	Art.	Ø mm	Ø Zoll Inch
20 1315 012	12	15/32"	20 1315 032	32	1.17/64"	20 1315 052	52	2.3/64"	20 1315 072	72	2.53/64"
20 1315 013	13	33/64"	20 1315 033	33	1.19/64"	20 1315 053	53	2.3/32"	20 1315 073	73	2.7/8"
20 1315 014	14	35/64"	20 1315 034	34	1.11/32"	20 1315 054	54	2.1/8"	20 1315 074	74	2.29/32"
20 1315 015	15	19/32"	20 1315 035	35	1.3/8"	20 1315 055	55	2.11/64"	20 1315 075	75	2.61/64"
20 1315 016	16	5/8"	20 1315 036	36	1.27/64"	20 1315 056	56	2.13/64"	20 1315 076	76	2.63/64"
20 1315 017	17	43/64"	20 1315 037	37	1.29/64"	20 1315 057	57	2.1/4"	20 1315 077	77	3.1/32"
20 1315 018	18	45/64"	20 1315 038	38	1.1/2"	20 1315 058	58	2.9/32"	20 1315 078	78	3.5/64"
20 1315 019	19	3/4"	20 1315 039	39	1.17/32"	20 1315 059	59	2.21/64"	20 1315 079	79	3.7/64"
20 1315 020	20	25/32"	20 1315 040	40	1.37/64"	20 1315 060	60	2.23/64"	20 1315 080	80	3.5/32"
20 1315 021	21	53/64"	20 1315 041	41	1.39/64"	20 1315 061	61	2.13/32"	20 1315 085	85	3.11/32"
20 1315 022	22	55/64"	20 1315 042	42	1.21/32"	20 1315 062	62	2.7/16"	20 1315 090	90	3.35/64"
20 1315 023	23	29/32"	20 1315 043	43	1.11/16"	20 1315 063	63	2.31/64"	20 1315 095	95	3.47/64"
20 1315 024	24	15/16"	20 1315 044	44	1.47/64"	20 1315 064	64	2.33/64"	20 1315 100	100	3.15/16"
20 1315 025	25	63/64"	20 1315 045	45	1.49/64"	20 1315 065	65	2.9/16"	20 1315 105	105	4.9/64"
20 1315 026	26	1.1/32"	20 1315 046	46	1.13/16"	20 1315 066	66	2.19/32"	20 1315 110	110	4.21/64"
20 1315 027	27	1.1/16"	20 1315 047	47	1.27/32"	20 1315 067	67	2.41/64"	20 1315 115	115	4.17/32"
20 1315 028	28	1.7/64"	20 1315 048	48	1.57/64"	20 1315 068	68	2.43/64"	20 1315 120	120	4.23/32"
20 1315 029	29	1.9/64"	20 1315 049	49	1.59/64"	20 1315 069	69	2.23/32"			
20 1315 030	30	1.3/16"	20 1315 050	50	1.31/32"	20 1315 070	70	2.3/4"			
20 1315 031	31	1.7/32"	20 1315 051	51	2.1/64"	20 1315 071	71	2.51/64"			

Größere Ø sowie Zwischenabmessungen Art. 20 1316 siehe Seite 384, Art. 20 1130A Seite 595, Art. 20 1141A Seite 599 ·

Achtung: Die Zollabmessungen entsprechen nicht exakt den mm Durchmessern.

Larger Ø and in between Ø see Art. 20 1316 page 384, Art. 20 1130A page 595, Art. 20 1141A page 599 ·

Attention: The inch sizes do not correspond exactly to the mm diameters.

20 1315

HARD-LINE 40

ZUBEHÖR • ACCESSORIES



AUSWERFERSTIFTE • EJECTOR PINS

Ø 12-17 mm • 20 1149

Packnorm 2 Stk. · Packaging unit 2 pcs.

Ø 18-65 mm • 20 1151

Packnorm 2 Stk. · Packaging unit 2 pcs.

Ø 66-120 mm • 20 1273

Packnorm 2 Stk. · Packaging unit 2 pcs.

20 1315

HARD-LINE 40

SETS / DISPLAYS Seite / Page 554



Wir bieten eine große Auswahl an Sets / Displays – Inhaltsvorschläge 20 1315 HARD-LINE40 – siehe Seite 554. Anderer Inhalt auf Wunsch möglich, durch individuell bestückbare Sets / Displays.

We offer a large selection of sets / displays – recommended content 20 1315 HARD-LINE40 – see page 554. Other content possible by individually equipped sets / displays.



Schnittdaten
Cutting data

Film
Movie



1487

- 1
- 2
- 3
- 4
- 5
- 6
- 7
- 8
- 9
- 10

Zubehör für Hartmetall-bestückte Kernbohrer, Weldonschaft, Nutzlänge 40 mm
 Accessories for carbide-tipped annular cutter, Weldon shank, drill depth 40 mm | 1.1/2"

HARD-LINE 40 20 1315

ADAPTER + PASSENDE AUSWERFERSTIFTE
ADAPTER + SUITABLE EJECTOR PINS

 **Ø 12-17 mm** • 20 1263

FEIN Quick-In 18 mm
 Weldon + Nitto/Universal 19 mm 3/4"

6,34 × 116 mm • 20 1318

Packnorm 2 Stk. · Packaging unit 2 pcs.

 **Ø 18-65 mm** • 20 1161

FEIN Quick-In 18 mm
 Weldon + Nitto/Universal 19 mm 3/4"

7,98 × 118 mm • 20 1272

Packnorm 2 Stk. · Packaging unit 2 pcs.

 **Ø 12-17 mm** • 20 1311

Nitto/Universal 19 mm 3/4"
 Weldon 19 mm 3/4"

6,34 × 116 mm • 20 1318

Packnorm 2 Stk. · Packaging unit 2 pcs.

 **Ø 18-65 mm** • 20 1314

Nitto/Universal 19 mm 3/4"
 Weldon 19 mm 3/4"

7,98 × 118 mm • 20 1272

Packnorm 2 Stk. · Packaging unit 2 pcs.

 **Ø 12-17 mm** • 21 0048

Weldon 32 mm 1.1/4"
 Weldon + Nitto/Universal 19 mm 3/4"

6,34 × 90 mm • 20 1149

Packnorm 2 Stk. · Packaging unit 2 pcs.

 **Ø 18-65 mm** • 20 1151

7,98 × 90 mm • 20 1151

Packnorm 2 Stk. · Packaging unit 2 pcs.

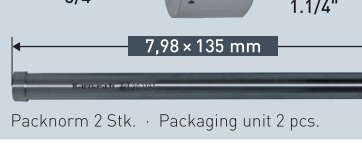
 **Ø 66-120 mm** • 20 1386

Weldon 19 mm 3/4"
 Weldon 32 mm 1.1/4"

7,98 × 135 mm • 20 1393

Packnorm 2 Stk. · Packaging unit 2 pcs.

Ersatz-Innensechskantschrauben für alle Adapter siehe Seite 550
 Spare allen screws for all adapters see page 550

Weiteres Zubehör siehe Übersichtsseite 375
 Further accessories see overview page 375

VERLÄNGERUNGEN + PASSENDE AUSWERFERSTIFTE
EXTENSIONS + SUITABLE EJECTOR PINS

 **Ø 12-17 mm** • 20 1387

Weldon 19 mm 3/4"
 Weldon + Nitto/Universal 19 mm 3/4"

7,98 × 6,34 × 5,30 × 140 mm • 20 1390

Packnorm 2 Stk. · Packaging unit 2 pcs.

 **Ø 18-65 mm** • 20 1387

Weldon 19 mm 3/4"
 Weldon + Nitto/Universal 19 mm 3/4"

7,98 × 135 mm • 20 1393

Packnorm 2 Stk. · Packaging unit 2 pcs.

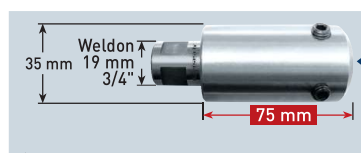
 **Ø 12-17 mm** • 20 1402

Weldon 19 mm 3/4"
 Weldon + Nitto/Universal 19 mm 3/4"

7,98 × 6,34 × 5,30 × 165 mm • 20 1405

Packnorm 2 Stk. · Packaging unit 2 pcs.

 **Ø 18-65 mm** • 20 1402

Weldon 19 mm 3/4"
 Weldon + Nitto/Universal 19 mm 3/4"

7,98 × 167 mm • 20 1408

Packnorm 2 Stk. · Packaging unit 2 pcs.

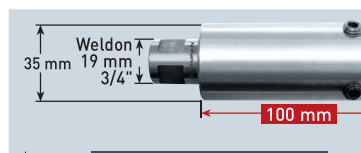
 **Ø 12-17 mm** • 20 1417

Weldon 19 mm 3/4"
 Weldon + Nitto/Universal 19 mm 3/4"

7,98 × 6,34 × 5,30 × 190 mm • 20 1420

Packnorm 2 Stk. · Packaging unit 2 pcs.

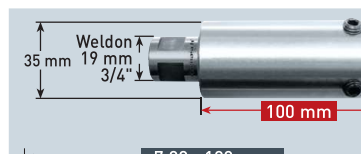
 **Ø 18-65 mm** • 20 1417

Weldon 19 mm 3/4"
 Weldon + Nitto/Universal 19 mm 3/4"

7,98 × 190 mm • 20 1423

Packnorm 2 Stk. · Packaging unit 2 pcs.

Ersatz-Innensechskantschrauben für alle Verlängerungen siehe Seite 550
 Spare allen screws for all extensions see page 550

Weiteres Zubehör siehe Übersichtsseite 375
 Further accessories see overview page 375



20 1316

HARD-LINE 55

Hartmetall-bestückter Kernbohrer, Weldonschaft, Nutzlänge 55 mm
Carbide-tipped annular cutter, Weldon shank, drill depth 55 mm | 2"



ANWENDUNG • APPLICATION

Stahl	Edelstahl	Grauguss	Alu	Kupfer, Messing, Zinn	Kunststoffe GFK/CFK	Hastelloy, Inconel, Exotische Materialien
Steel	Stainless	Grey cast iron	Alu	Copper, brass, tin	Plastics GRP/CRP	Hastelloy, Inconel, exotic materials
< 1400 N	> 900 N		> 10% Si			

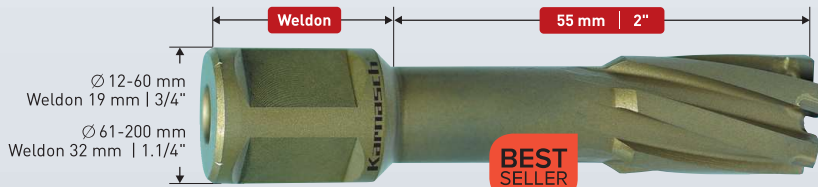

BEST SELLER

☞ Sonderpreis / Sale Artikel. Lieferbar solange Vorrat.
Special price / sale article. While stocks last.

Bestseller – preisreduziert • Bestseller – price reduced

Art.	Ø mm	Ø Zoll Inch	Art.	Ø mm	Ø Zoll Inch	Art.	Ø mm	Ø Zoll Inch	Art.	Ø mm	Ø Zoll Inch
20 1316 012	12	15/32"	20 1316 035	35	1.3/8"	20 1316 062	62	2.7/16"	20 1316 100	100	3.15/16"
20 1316 013	13	33/64"	20 1316 036	36	1.27/64"	20 1316 063	63	2.31/64"	20 1316 103	103	4.1/16"
20 1316 014	14	35/64"	20 1316 037	37	1.29/64"	20 1316 064	64	2.33/64"	20 1316 104	104	4.3/32"
20 1316 015	15	19/32"	20 1316 038	38	1.1/2"	20 1316 065	65	2.9/16"	20 1316 105	105	4.9/64"
20 1316 016	16	5/8"	20 1316 039	39	1.17/32"	20 1316 066	66	2.19/32"	20 1316 106	106	4.11/64"
20 1316 017	17	43/64"	20 1316 040	40	1.37/64"	20 1316 067	67	2.41/64"	20 1316 108	108	4.1/4"
20 1316 0175	17.5	11/16"	20 1316 041	41	1.39/64"	20 1316 068	68	2.43/64"	20 1316 110	110	4.21/64"
20 1316 018	18	45/64"	20 1316 042	42	1.21/32"	20 1316 069	69	2.23/32"	20 1316 115	115	4.17/32"
20 1316 019	19	3/4"	20 1316 043	43	1.11/16"	20 1316 070	70	2.3/4"	20 1316 120	120	4.23/32"
20 1316 020	20	25/32"	20 1316 044	44	1.47/64"	20 1316 071	71	2.51/64"	20 1316 125	125	4.59/64"
20 1316 021	21	53/64"	20 1316 045	45	1.49/64"	20 1316 072	72	2.53/64"	20 1316 130	130	5.1/8"
20 1316 0215	21.5	27/32"	20 1316 046	46	1.13/16"	20 1316 073	73	2.7/8"	20 1316 135	135	5.5/16"
20 1316 022	22	55/64"	20 1316 047	47	1.27/32"	20 1316 074	74	2.29/32"	20 1316 140	140	5.33/64"
20 1316 023	23	29/32"	20 1316 048	48	1.57/64"	20 1316 075	75	2.61/64"	20 1316 145	145	5.45/64"
20 1316 0235	23.5	59/64"	20 1316 049	49	1.59/64"	20 1316 076	76	2.63/64"	20 1316 150	150	5.29/32"
20 1316 024	24	15/16"	20 1316 050	50	1.31/32"	20 1316 077	77	3.1/32"	20 1316 155	155	6.7/64"
20 1316 025	25	63/64"	20 1316 051	51	2.1/64"	20 1316 078	78	3.5/64"	20 1316 160	160	6.19/64"
20 1316 0255	25.5	1"	20 1316 052	52	2.3/64"	20 1316 079	79	3.7/64"	20 1316 165	165	6.1/2"
20 1316 026	26	1.1/32"	20 1316 053	53	2.3/32"	20 1316 080	80	3.5/32"	20 1316 170	170	6.11/16"
20 1316 027	27	1.1/16"	20 1316 054	54	2.1/8"	20 1316 082	82	3.15/64"	20 1316 175	175	6.57/64"
20 1316 028	28	1.7/64"	20 1316 055	55	2.11/64"	20 1316 083	83	3.17/64"	20 1316 180	180	7.3/32"
20 1316 029	29	1.9/64"	20 1316 056	56	2.13/64"	20 1316 084	84	3.5/16"	20 1316 185	185	7.9/32"
20 1316 030	30	1.3/16"	20 1316 057	57	2.1/4"	20 1316 085	85	3.11/32"	20 1316 190	190	7.31/64"
20 1316 031	31	1.7/32"	20 1316 058	58	2.9/32"	20 1316 088	88	3.15/32"	20 1316 195	195	7.43/64"
20 1316 032	32	1.17/64"	20 1316 059	59	2.21/64"	20 1316 090	90	3.35/64"	20 1316 200	200	7.7/8"
20 1316 033	33	1.19/64"	20 1316 060	60	2.23/64"	20 1316 092	92	3.5/8"			
20 1316 034	34	1.11/32"	20 1316 061	61	2.13/32"	20 1316 095	95	3.47/64"			

Achtung: Die Zollabmessungen entsprechen nicht exakt den mm Durchmessern. • Attention: The inch sizes do not correspond exactly to the mm diameters.

20 1316

HARD-LINE 55

ZUBEHÖR • ACCESSORIES



AUSWERFERSTIFTE • EJECTOR PINS

☞ Ø 12-17,5 mm • 20 1271

Packnorm 2 Stk. • Packaging unit 2 pcs.

☞ Ø 18-60 mm • 20 1273

Packnorm 2 Stk. • Packaging unit 2 pcs.

☞ Ø 61-200 mm • 20 1272

Packnorm 2 Stk. • Packaging unit 2 pcs.

20 1316

HARD-LINE 55

SETS / DISPLAYS Seite / Page 555



Wir bieten eine große Auswahl an Sets / Displays – Inhaltsvorschläge 20 1316 HARD-LINE55 – siehe Seite 555. Anderer Inhalt auf Wunsch möglich, durch individuell bestückbare Sets / Displays.

We offer a large selection of sets / displays – recommended content 20 1316 HARD-LINE55 – see page 555. Other content possible by individually equipped sets / displays.



Schnittdaten
Cutting data

Film
Movie







1487

Zubehör für Hartmetall-bestückte Kernbohrer, Weldonschaft, Nutzlänge 55 mm
 Accessories for carbide-tipped annular cutter, Weldon shank, drill depth 55 mm | 2"

HARD-LINE 55 20 1316

ADAPTER + PASSENDE AUSWERFERSTIFTE
ADAPTER + SUITABLE EJECTOR PINS

 **Ø 12-17,5 mm • 20 1263**
 FEIN Quick-In 18 mm Weldon + Nitto/Universal 19 mm 3/4"
 **• 20 1160**
 Packnorm 2 Stk. · Packaging unit 2 pcs.

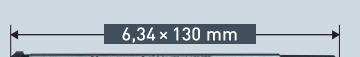

 **Ø 18-60 mm • 20 1161**
 FEIN Quick-In 18 mm Weldon + Nitto/Universal 19 mm 3/4"
 **• 20 1439**
 Packnorm 2 Stk. · Packaging unit 2 pcs.

 **Ø 12-17,5 mm • 20 1311**
 Nitto/Universal 19 mm 3/4" Weldon 19 mm 3/4"
 **• 20 1160**
 Packnorm 2 Stk. · Packaging unit 2 pcs.

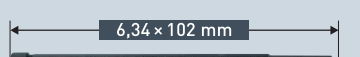
 **Ø 18-60 mm • 20 1314**
 Nitto/Universal 19 mm 3/4" Weldon 19 mm 3/4"
 **• 20 1439**
 Packnorm 2 Stk. · Packaging unit 2 pcs.

 **• 21 0048**
 Weldon 32 mm 1.1/4" Weldon + Nitto/Universal 19 mm 3/4"
 **Ø 12-17,5 mm • 20 1271**
 Packnorm 2 Stk. · Packaging unit 2 pcs.

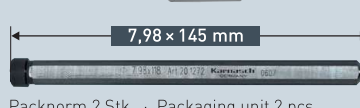

 **Ø 18-60 mm • 20 1273**
 **• 20 1439**
 Packnorm 2 Stk. · Packaging unit 2 pcs.



 **Ø 61-150 mm • 20 1386**
 Weldon 19 mm 3/4" Weldon 32 mm 1.1/4"
 **• 20 1403**
 Packnorm 2 Stk. · Packaging unit 2 pcs.

Ersatz-Innensechskantschrauben für alle Adapter siehe Seite 550
 Spare allen screws for all adapters see page 550

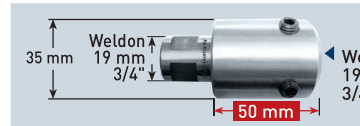

Weiteres Zubehör siehe Übersichtsseite 375
 Further accessories see overview page 375

VERLÄNGERUNGEN + PASSENDE AUSWERFERSTIFTE
EXTENSIONS + SUITABLE EJECTOR PINS

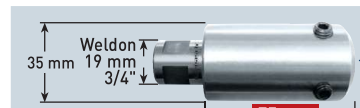

 **Ø 12-17,5 mm • 20 1387**
 35 mm Weldon 19 mm 3/4" Weldon + Nitto/Universal 19 mm 3/4"
 **• 20 1396**
 Packnorm 2 Stk. · Packaging unit 2 pcs.

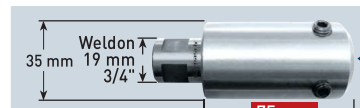
 **Ø 18-60 mm • 20 1387**
 35 mm Weldon 19 mm 3/4" Weldon + Nitto/Universal 19 mm 3/4"
 **• 20 1399**
 Packnorm 2 Stk. · Packaging unit 2 pcs.

 **Ø 12-17,5 mm • 20 1402**
 35 mm Weldon 19 mm 3/4" Weldon + Nitto/Universal 19 mm 3/4"
 **• 20 1411**
 Packnorm 2 Stk. · Packaging unit 2 pcs.

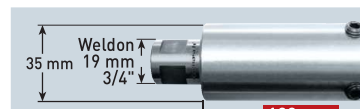
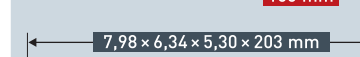
 **Ø 18-60 mm • 20 1402**
 35 mm Weldon 19 mm 3/4" Weldon + Nitto/Universal 19 mm 3/4"
 **• 20 1414**
 Packnorm 2 Stk. · Packaging unit 2 pcs.

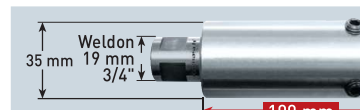
 **Ø 12-17,5 mm • 20 1417**
 35 mm Weldon 19 mm 3/4" Weldon + Nitto/Universal 19 mm 3/4"
 **• 20 1426**
 Packnorm 2 Stk. · Packaging unit 2 pcs.

 **Ø 18-60 mm • 20 1417**
 35 mm Weldon 19 mm 3/4" Weldon + Nitto/Universal 19 mm 3/4"
 **• 20 1429**
 Packnorm 2 Stk. · Packaging unit 2 pcs.

Ersatz-Innensechskantschrauben für alle Verlängerungen siehe Seite 550
 Spare allen screws for all extensions see page 550

Weiteres Zubehör siehe Übersichtsseite 375
 Further accessories see overview page 375



20 1650

HARD-LINE 80

Hartmetall-bestückter Kernbohrer, Weldonschaft, Nutzlänge 80 mm
Carbide-tipped annular cutter, Weldon shank, drill depth 80 mm | 3"



ANWENDUNG • APPLICATION

Stahl	Edelstahl	Grauguss	Alu	Kupfer, Messing, Zinn	Kunststoffe GFK/CFK	Hastelloy, Inconel, Exotische Materialien
Steel	Stainless	Grey cast iron	Alu	Copper, brass, tin	Plastics GRP/CRP	Hastelloy, Inconel, exotic materials
< 1400 N	> 900 N		> 10% Si			

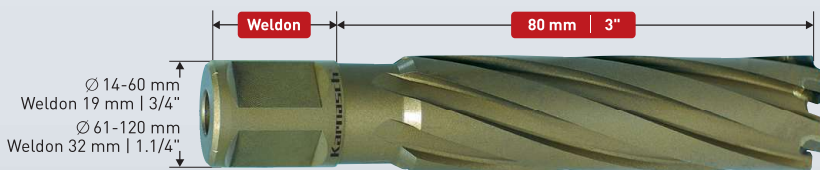

☞ Sonderpreis / Sale Artikel. Lieferbar solange Vorrat.
Special price / sale article. While stocks last.

Art.	Ø mm	Ø Zoll Inch	Art.	Ø mm	Ø Zoll Inch	Art.	Ø mm	Ø Zoll Inch	Art.	Ø mm	Ø Zoll Inch
20 1650 014	• 14	35/64"	20 1650 034	• 34	1.11/32"	20 1650 054	• 54	2.1/8"	20 1650 075	• 75	2.61/64"
20 1650 015	• 15	19/32"	20 1650 035	• 35	1.3/8"	20 1650 055	• 55	2.11/64"	20 1650 076	• 76	2.63/64"
20 1650 016	• 16	5/8"	20 1650 036	• 36	1.27/64"	20 1650 056	• 56	2.13/64"	20 1650 078	• 78	3.5/64"
20 1650 017	• 17	43/64"	20 1650 037	• 37	1.29/64"	20 1650 057	• 57	2.1/4"	20 1650 080	• 80	3.5/32"
20 1650 018	• 18	45/64"	20 1650 038	• 38	1.1/2"	20 1650 058	• 58	2.9/32"	20 1650 082	• 82	3.15/64"
20 1650 019	• 19	3/4"	20 1650 039	• 39	1.17/32"	20 1650 059	• 59	2.21/64"	20 1650 085	• 85	3.11/32"
20 1650 020	• 20	25/32"	20 1650 040	• 40	1.37/64"	20 1650 060	• 60	2.23/64"	20 1650 090	• 90	3.35/64"
20 1650 021	• 21	53/64"	20 1650 041	• 41	1.39/64"	20 1650 061	• 61	2.13/32"	20 1650 095	☞ 95	3.47/64"
20 1650 022	• 22	55/64"	20 1650 042	• 42	1.21/32"	20 1650 062	• 62	2.7/16"	20 1650 100	• 100	3.15/16"
20 1650 023	• 23	29/32"	20 1650 043	• 43	1.11/16"	20 1650 063	• 63	2.31/64"	20 1650 103	• 103	4.1/16"
20 1650 024	• 24	15/16"	20 1650 044	• 44	1.47/64"	20 1650 064	• 64	2.33/64"	20 1650 104	• 104	4.3/32"
20 1650 025	• 25	63/64"	20 1650 045	• 45	1.49/64"	20 1650 065	• 65	2.9/16"	20 1650 105	• 105	4.9/64"
20 1650 026	• 26	1.1/32"	20 1650 046	• 46	1.13/16"	20 1650 066	• 66	2.19/32"	20 1650 106	☞ 106	4.11/64"
20 1650 027	• 27	1.1/16"	20 1650 047	• 47	1.27/32"	20 1650 067	• 67	2.41/64"	20 1650 108	• 108	4.1/4"
20 1650 028	• 28	1.7/64"	20 1650 048	• 48	1.57/64"	20 1650 068	• 68	2.43/64"	20 1650 110	• 110	4.21/64"
20 1650 029	• 29	1.9/64"	20 1650 049	• 49	1.59/64"	20 1650 069	• 69	2.23/32"	20 1650 115	• 115	4.17/32"
20 1650 030	• 30	1.3/16"	20 1650 050	• 50	1.31/32"	20 1650 070	• 70	2.3/4"	20 1650 120	• 120	4.23/32"
20 1650 031	• 31	1.7/32"	20 1650 051	• 51	2.1/64"	20 1650 072	• 72	2.53/64"			
20 1650 032	• 32	1.17/64"	20 1650 052	• 52	2.3/64"	20 1650 073	• 73	2.7/8"			
20 1650 033	• 33	1.19/64"	20 1650 053	• 53	2.3/32"	20 1650 074	• 74	2.29/32"			

Achtung: Die Zollabmessungen entsprechen nicht exakt den mm Durchmesser.
Attention: The inch sizes do not correspond exactly to the mm diameters.

20 1650

HARD-LINE 80

ZUBEHÖR • ACCESSORIES



AUSWERFERSTIFTE 1 + 2-TEILIG EJECTOR PINS 1 + 2-PIECE



Packnorm 2 Stk. - Packaging unit 2 pcs.

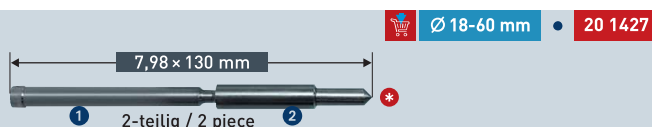

Packnorm 2 Stk. - Packaging unit 2 pcs.

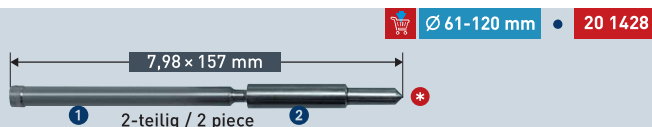

Packnorm 2 Stk. - Packaging unit 2 pcs.

ANWENDUNG AUSWERFERSTIFTE 2-TEILIG APPLICATION EJECTOR PINS 2-PIECE



Anwendung:

Teil 1 in den Schaft des Kernbohrers einführen. Teil 2 auf Teil 1 schieben. Bohren Sie bis ca. 50 mm Schnitttiefe. Danach Teil 2 entfernen und weiter bohren.

Application:

Insert piece 1 into the annular cutter shank. Push piece 2 onto part 1. Drill as deep as 50 mm cutting depth. Then remove piece 2 and continue drilling.

* Warum 2-teilige Auswerferstifte? In der Regel haben Standard Morsekonus-Aufnahmehalter eine Schnitttiefenkapazität von 50 mm. Wenn keine extra langen Aufnahmehalter verwendet werden (wie auf Seite 542-543 Art. 20 1842, 20 1291, 20 1843, 20 1845, 20 1846), müssen bei Schnitttiefen über 50 mm 2-teilige Auswerferstifte verwendet werden.

* Why use 2-part ejector pins? Usually, standard morse taper holders have a cutting depth capacity of 50 mm. If no extra-long holders are used (e.g. as on page 542-543 Art. 20 1842, 20 1291, 20 1843, 20 1845, 20 1846), you need for drill depths above 50 mm 2-part ejector pins.

Einteilige Auswerferstifte siehe nächste Seite • One-piece ejector pins see next page

Schnittdaten
Cutting data

Film
Movie



1487



Zubehör für Hartmetall-bestückte Kernbohrer, Weldonschaft, Nutzlänge 80 mm
Accessories for carbide-tipped annular cutter, Weldon shank, drill depth 80 mm | 3"

HARD-LINE 80 20 1650

ADAPTER + PASSENDE AUSWERFERSTIFTE
ADAPTER + SUITABLE EJECTOR PINS

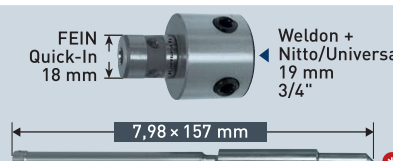
 FEIN Quick-In 18 mm | Weldon + Nitto/Universal 19 mm 3/4"

Ø 18-60 mm • 20 1161

7,98 × 157 mm

1 2-teilig / 2 piece 2 *

Packnorm 2 Stk. · Packaging unit 2 pcs.

• 20 1436

 Nitto/Universal 19 mm 3/4" | Weldon 19 mm 3/4"

Ø 18-60 mm • 20 1314

7,98 × 157 mm

1 2-teilig / 2 piece 2 *

Packnorm 2 Stk. · Packaging unit 2 pcs.

• 20 1436

 Weldon 32 mm 1.1/4" | Weldon + Nitto/Universal 19 mm 3/4"

• 21 0048

6,34 × 130 mm

1-teilig / 1 piece

Packnorm 2 Stk. · Packaging unit 2 pcs.

• 20 1302

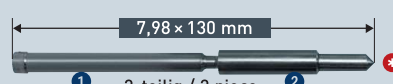
 7,98 × 130 mm

Ø 18-60 mm • 20 1427

1 2-teilig / 2 piece 2 *

Packnorm 2 Stk. · Packaging unit 2 pcs.

 7,98 × 130 mm

Ø 18-60 mm • 20 1439

1-teilig / 1 piece

Packnorm 2 Stk. · Packaging unit 2 pcs.

 Weldon 19 mm 3/4" | Weldon 32 mm 1.1/4"

Ø 61-120 mm • 20 1386

7,98 × 168 mm

1 2-teilig / 2 piece 2 *

Packnorm 2 Stk. · Packaging unit 2 pcs.

• 20 1486

 7,98 × 167 mm

• 20 1408

1-teilig / 1 piece

Packnorm 2 Stk. · Packaging unit 2 pcs.

* Erklärung 1-teilige / 2-teilige Auswerferstifte beachten
Please note explanation 1-part / 2-part pins

Ersatz-Innensechskantschrauben für alle Adapter siehe Seite 550
Spare allen screws for all adapters see page 550

Weiteres Zubehör siehe Übersichtsseite 375
Further accessories see overview page 375

AUSWERFERSTIFTE 1-TEILIG
EJECTOR PINS 1-PIECE

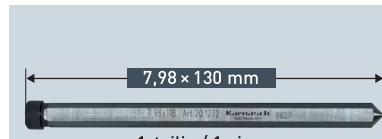
 7,98 × 130 mm

Ø 18-60 mm • 20 1439

1-teilig / 1 piece

Packnorm 2 Stk. · Packaging unit 2 pcs.

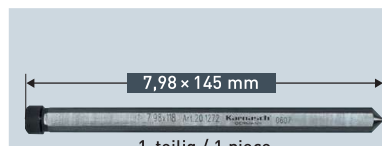
 7,98 × 145 mm

Ø 61-120 mm • 20 1403

1-teilig / 1 piece

Packnorm 2 Stk. · Packaging unit 2 pcs.

Zusammen mit Aufnahmehalter 20 1842, 20 1291, 20 1843, 20 1845, 20 1846 (siehe Seite 542-543) kann dieser einteilige Auswerferstift verwendet werden. Es kann ohne Umstecken bis 110 mm Schnitttiefe in einem Arbeitsgang gebohrt werden. Robust und einfach.

It is possible to use this one-piece ejector pin in combination with tool holder article 20 1842, 20 1291, 20 1843, 20 1845, 20 1846 (see page 542-543). You can drill as deep as 110 mm in one working process without changing. Robust and easy.



20 1660

HARD-LINE / 110

Hartmetall-bestückter Kernbohrer, Weldonschaft, Nutzlänge 110 mm
Carbide-tipped annular cutter, Weldon shank, drill depth 110 mm | 4"



ANWENDUNG • APPLICATION

Stahl	Edelstahl	Grauguss	Alu	Kupfer, Messing, Zinn	Kunststoffe GFK/CFK	Hastelloy, Inconel, Exotische Materialien
Steel	Stainless	Grey cast iron	Alu	Copper, brass, tin	Plastics GRP/CRP	Hastelloy, Inconel, exotic materials
< 1400 N	> 900 N		> 10% Si			

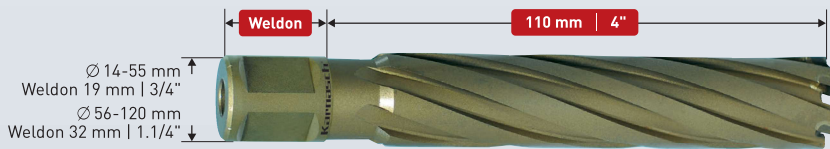

☒ Sonderpreis / Sale Artikel. Lieferbar solange Vorrat.
Special price / sale article. While stocks last.

Art.	Ø mm	Ø Zoll Inch	Art.	Ø mm	Ø Zoll Inch	Art.	Ø mm	Ø Zoll Inch	Art.	Ø mm	Ø Zoll Inch
20 1660 014	• 14	35/64"	20 1660 034	• 34	1.11/32"	20 1660 054	• 54	2.1/8"	20 1660 075	• 75	2.61/64"
20 1660 015	• 15	19/32"	20 1660 035	• 35	1.3/8"	20 1660 055	• 55	2.11/64"	20 1660 076	• 76	2.63/64"
20 1660 016	• 16	5/8"	20 1660 036	• 36	1.27/64"	20 1660 056	• 56	2.13/64"	20 1660 078	• 78	3.5/64"
20 1660 017	• 17	43/64"	20 1660 037	• 37	1.29/64"	20 1660 057	• 57	2.1/4"	20 1660 080	• 80	3.5/32"
20 1660 018	• 18	45/64"	20 1660 038	• 38	1.1/2"	20 1660 058	• 58	2.9/32"	20 1660 082	• 82	3.15/64"
20 1660 019	• 19	3/4"	20 1660 039	• 39	1.17/32"	20 1660 059	• 59	2.21/64"	20 1660 085	• 85	3.11/32"
20 1660 020	• 20	25/32"	20 1660 040	• 40	1.37/64"	20 1660 060	• 60	2.23/64"	20 1660 090	• 90	3.35/64"
20 1660 021	• 21	53/64"	20 1660 041	• 41	1.39/64"	20 1660 061	• 61	2.13/32"	20 1660 095	• 95	3.47/64"
20 1660 022	• 22	55/64"	20 1660 042	• 42	1.21/32"	20 1660 062	• 62	2.7/16"	20 1660 100	• 100	3.15/16"
20 1660 023	• 23	29/32"	20 1660 043	• 43	1.11/16"	20 1660 063	• 63	2.31/64"	20 1660 103	☒ 103	4.1/16"
20 1660 024	• 24	15/16"	20 1660 044	• 44	1.47/64"	20 1660 064	• 64	2.33/64"	20 1660 104	☒ 104	4.3/32"
20 1660 025	• 25	63/64"	20 1660 045	• 45	1.49/64"	20 1660 065	• 65	2.9/16"	20 1660 105	• 105	4.9/64"
20 1660 026	• 26	1.1/32"	20 1660 046	• 46	1.13/16"	20 1660 066	• 66	2.19/32"	20 1660 106	☒ 106	4.11/64"
20 1660 027	• 27	1.1/16"	20 1660 047	• 47	1.27/32"	20 1660 067	☒ 67	2.41/64"	20 1660 108	• 108	4.1/4"
20 1660 028	• 28	1.7/64"	20 1660 048	• 48	1.57/64"	20 1660 068	• 68	2.43/64"	20 1660 110	• 110	4.21/64"
20 1660 029	• 29	1.9/64"	20 1660 049	• 49	1.59/64"	20 1660 069	• 69	2.23/32"	20 1660 115	• 115	4.17/32"
20 1660 030	• 30	1.3/16"	20 1660 050	• 50	1.31/32"	20 1660 070	• 70	2.3/4"	20 1660 120	• 120	4.23/32"
20 1660 031	• 31	1.7/32"	20 1660 051	• 51	2.1/64"	20 1660 072	• 72	2.53/64"			
20 1660 032	• 32	1.17/64"	20 1660 052	• 52	2.3/64"	20 1660 073	• 73	2.7/8"			
20 1660 033	• 33	1.19/64"	20 1660 053	• 53	2.3/32"	20 1660 074	• 74	2.29/32"			

Achtung: Die Zollabmessungen entsprechen nicht exakt den mm Durchmessern. - Attention: The inch sizes do not correspond exactly to the mm diameters.

20 1660

HARD-LINE / 110

ZUBEHÖR • ACCESSORIES



AUSWERFERSTIFTE 1 + 2-TEILIG EJECTOR PINS 1 + 2-PIECE



1-teilig / 1 piece

Packnorm 2 Stk. - Packaging unit 2 pcs.



2-teilig / 2 piece

Packnorm 2 Stk. - Packaging unit 2 pcs.



2-teilig / 2 piece

Packnorm 2 Stk. - Packaging unit 2 pcs.

ANWENDUNG AUSWERFERSTIFTE 2-TEILIG APPLICATION EJECTOR PINS 2-PIECE



Anwendung:

Teil 1 in den Schaft des Kernbohrers einführen. Teil 2 auf Teil 1 schieben. Bohren Sie bis ca. 50 mm Schnitttiefe. Danach Teil 2 entfernen und weiter bohren.

Application:

Insert piece 1 into the annular cutter shank. Push piece 2 onto part 1. Drill as deep as 50 mm cutting depth. Then remove piece 2 and continue drilling.

☒ Warum 2-teilige Auswerferstifte? In der Regel haben Standard Morsekonus-Aufnahmehalter eine Schnitttiefenkapazität von 50 mm. Wenn keine extra langen Aufnahmehalter verwendet werden (wie auf Seite 542-543 Art. 20 1842, 20 1291, 20 1843, 20 1845, 20 1846), müssen bei Schnitttiefen über 50 mm 2-teilige Auswerferstifte verwendet werden.

☒ Why use 2-part ejector pins? Usually, standard morse taper holders have a cutting depth capacity of 50 mm. If no extra-long holders are used (e.g. as on page 542-543 Art. 20 1842, 20 1291, 20 1843, 20 1845, 20 1846), you need for drill depths above 50 mm 2-part ejector pins.

Einteilige Auswerferstifte siehe nächste Seite - One-piece ejector pins see next page

Schnittdaten
Cutting data

Film
Movie



1487



Zubehör für Hartmetall-bestückte Kernbohrer, Weldonschaft, Nutzlänge 110 mm
 Accessories for carbide-tipped annular cutter, Weldon shank, drill depth 110 mm | 4"

HARD-LINE 110 20 1660

**ADAPTER + PASSENDE AUSWERFERSTIFTE
 ADAPTER + SUITABLE EJECTOR PINS**

FEIN Quick-In 18 mm | Weldon + Nitto/Universal 19 mm 3/4" | **Ø 18-55 mm • 20 1161**

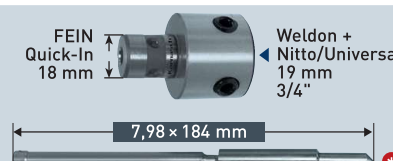

7,98 x 184 mm | **• 20 1438**

1 2-teilig / 2 piece 2

Packnorm 2 Stk. · Packaging unit 2 pcs.

Nitto/Universal 19 mm 3/4" | Weldon 19 mm 3/4" | **Ø 18-55 mm • 20 1314**

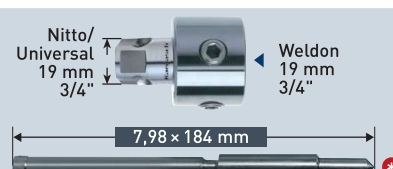

7,98 x 184 mm | **• 20 1438**

1 2-teilig / 2 piece 2

Packnorm 2 Stk. · Packaging unit 2 pcs.

Weldon 32 mm 1.1/4" | Weldon + Nitto/Universal 19 mm 3/4" | **• 21 0048**



6,34 x 160 mm | **Ø 14-17 mm • 20 1304**

1-teilig / 1 piece

Packnorm 2 Stk. · Packaging unit 2 pcs.

7,98 x 160 mm | **Ø 18-55 mm • 20 1399**

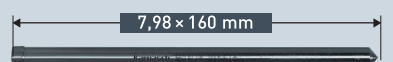

1-teilig / 1 piece

Packnorm 2 Stk. · Packaging unit 2 pcs.

7,98 x 157 mm | **Ø 18-55 mm • 20 1428**

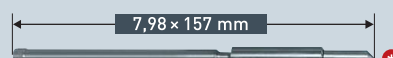

1 2-teilig / 2 piece 2

Packnorm 2 Stk. · Packaging unit 2 pcs.

Weldon 19 mm 3/4" | Weldon 32 mm 1.1/4" | **Ø 56-120 mm • 20 1386**

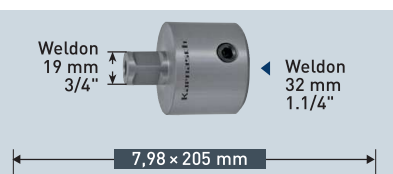

7,98 x 205 mm | **• 20 1152**

1 2-teilig / 2 piece 2

Packnorm 2 Stk. · Packaging unit 2 pcs.

7,98 x 205 mm | **• 20 1429**

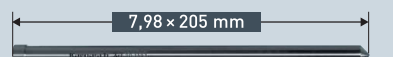

1-teilig / 1 piece

Packnorm 2 Stk. · Packaging unit 2 pcs.

* Erklärung 1-teilige / 2-teilige Auswerferstifte beachten
 Please note explanation 1-part / 2-part pins

**AUSWERFERSTIFTE 1-TEILIG
 EJECTOR PINS 1-PIECE**

Ø 18-55 mm • 20 1399

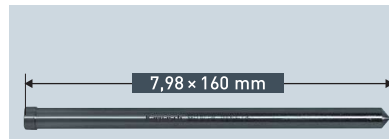

7,98 x 160 mm

1-teilig / 1 piece

Packnorm 2 Stk. · Packaging unit 2 pcs.

Ø 56-120 mm • 20 1408



7,98 x 167 mm

1-teilig / 1 piece

Packnorm 2 Stk. · Packaging unit 2 pcs.

Zusammen mit Aufnahmehalter 20 1842, 20 1291, 20 1843, 20 1845, 20 1846 (siehe Seite 542-543) kann dieser einteilige Auswerferstift verwendet werden. Es kann ohne Umstecken bis 110 mm Schnitttiefe in einem Arbeitsgang gebohrt werden. Robust und einfach.

It is possible to use this one-piece ejector pin in combination with tool holder article 20 1842, 20 1291, 20 1843, 20 1845, 20 1846 (see page 542-543). You can drill as deep as 110 mm in one working process without changing. Robust and easy.

Ersatz-Innensechskantschrauben für alle Adapter siehe Seite 550
 Spare allen screws for all adapters see page 550

Weiteres Zubehör siehe Übersichtsseite 375
 Further accessories see overview page 375



20 1665

HARD-LINE / 150

Hartmetall-bestückter Kernbohrer, Weldonschaft, Nutzlänge 150 mm
Carbide-tipped annular cutter, Weldon shank, drill depth 150 mm | 5.29/32"



ANWENDUNG • APPLICATION

Stahl	Edelstahl	Grauguss	Alu	Kupfer, Messing, Zinn	Kunststoffe GFK/CFK	Hastelloy, Inconel, Exotische Materialien
Steel	Stainless	Grey cast iron	Alu	Copper, brass, tin	Plastics GRP/CRP	Hastelloy, Inconel, exotic materials
< 1400 N	> 900 N		> 10% Si			

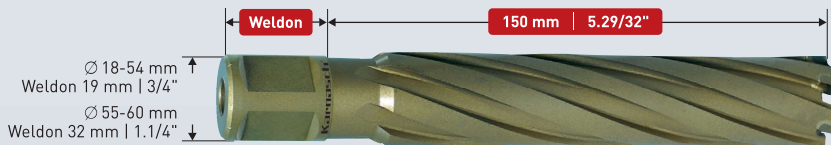

Art.	Ø mm	Ø Zoll Inch	Art.	Ø mm	Ø Zoll Inch	Art.	Ø mm	Ø Zoll Inch	Art.	Ø mm	Ø Zoll Inch
20 1665 018	• 18	45/64"	20 1665 030	• 30	1.3/16"	20 1665 042	• 42	1.21/32"	20 1665 054	• 54	2.1/8"
20 1665 019	• 19	3/4"	20 1665 031	• 31	1.7/32"	20 1665 043	• 43	1.11/16"	20 1665 055	• 55	2.11/64"
20 1665 020	• 20	25/32"	20 1665 032	• 32	1.17/64"	20 1665 044	• 44	1.47/64"	20 1665 056	• 56	2.13/64"
20 1665 021	• 21	53/64"	20 1665 033	• 33	1.19/64"	20 1665 045	• 45	1.49/64"	20 1665 057	• 57	2.1/4"
20 1665 022	• 22	55/64"	20 1665 034	• 34	1.11/32"	20 1665 046	• 46	1.13/16"	20 1665 058	• 58	2.9/32"
20 1665 023	• 23	29/32"	20 1665 035	• 35	1.3/8"	20 1665 047	• 47	1.27/32"	20 1665 059	• 59	2.21/64"
20 1665 024	• 24	15/16"	20 1665 036	• 36	1.27/64"	20 1665 048	• 48	1.57/64"	20 1665 060	• 60	2.23/64"
20 1665 025	• 25	63/64"	20 1665 037	• 37	1.29/64"	20 1665 049	• 49	1.59/64"			
20 1665 026	• 26	1.1/32"	20 1665 038	• 38	1.1/2"	20 1665 050	• 50	1.31/32"			
20 1665 027	• 27	1.1/16"	20 1665 039	• 39	1.17/32"	20 1665 051	• 51	2.1/64"			
20 1665 028	• 28	1.7/64"	20 1665 040	• 40	1.37/64"	20 1665 052	• 52	2.3/64"			
20 1665 029	• 29	1.9/64"	20 1665 041	• 41	1.39/64"	20 1665 053	• 53	2.3/32"			

20 1665

HARD-LINE / 150

ZUBEHÖR • ACCESSORIES

AUSWERFERSTIFTE 1 + 2-TEILIG EJECTOR PINS 1 + 2-PIECE

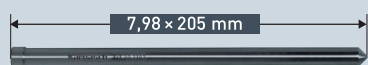

Ø 18-19 mm • 20 1429

1-teilig / 1 piece

Packnorm 2 Stk. • Packaging unit 2 pcs.



• 20 1399

1-teilig / 1 piece

Packnorm 2 Stk. • Packaging unit 2 pcs.



Ø 20-54 mm • 20 1152

2-teilig / 2 piece

Packnorm 2 Stk. • Packaging unit 2 pcs.

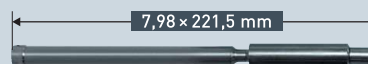

Ø 55-60 mm • 20 1124

2-teilig / 2 piece

Packnorm 2 Stk. • Packaging unit 2 pcs.

ANWENDUNG AUSWERFERSTIFTE 1-TEILIG Ø 18-19 mm APPLICATION EJECTOR PINS 1-PIECE Ø 18-19 mm

Verwenden Sie Auswerferstifte Art. 20 1429 und bohren Sie bis ca. 80 mm Tiefe

Mount pin Art. 20 1429 into the cutter and drill up to 80 mm cutting depth



Entfernen Sie den Kernbohrer aus der Maschine und wechseln Sie auf Auswerferstift Art. 20 1399 und bohren Sie bis zu 150 mm Tiefe weiter.

Take off the cutter and use pin Art. 20 1399 and continue drilling up to 150 mm cutting depth.

ANWENDUNG AUSWERFERSTIFTE 2-TEILIG APPLICATION EJECTOR PINS 2-PIECE



Anwendung:

Teil 1 in den Schaft des Kernbohrers einführen. Teil 2 auf Teil 1 schieben. Bohren Sie bis ca. 80 mm Schnitttiefe. Danach Teil 2 entfernen und weiter bohren bis zu 150 mm Schnitttiefe.

Application:

Insert piece 1 into the annular cutter shank. Push piece 2 onto part 1. Drill as deep as 80 mm cutting depth. Then remove piece 2 and continue drilling up to cutting depth 150 mm.

ACHTUNG: Die Anwendung dieser 1+2-teiligen Auswerferstifte funktioniert nur mit extra langen Aufnahmen mit Morsekegel siehe Art. 20 1842, 20 1291, 20 1843, 20 1845, 20 1846 Seite 542/543

ATTENTION: The use of these 1+2-part ejector pins works only with extra long morse taper holders see Art. 20 1842, 20 1291, 20 1843, 20 1845, 20 1846 page 542/543

Schnittdaten

Cutting data

Film

Movie



1487



Qualitätsprodukte für die Metallbearbeitung.
Quality products for metalworking.

EFFIZIENZ

FÜR DIE METALLVERARBEITENDE INDUSTRIE

Efficiency for the metalworking industry



DAS KARNASCH PRODUKTSORTIMENT ONLINE! Nutzen Sie unseren Onlineshop und profitieren Sie von den speziellen Vorteilen für Onlineshop-Kunden.

THE KARNASCH PRODUCT RANGE ONLINE! Use our onlineshop and benefit from the special advantages for onlineshop customers.

 <https://karnasch.tools>

1



2



3



4



5



6



7



8



9



10

Index

20 1930

HARD-LINE
ZOLL / INCH **40**

Hartmetall-bestückter Kernbohrer, Weldonschaft, Nutzlänge 40 mm
Carbide-tipped annular cutter, Weldon shank, drill depth 40 mm | 1.1/2"



ANWENDUNG • APPLICATION

Stahl	Edelstahl	Grauguss	Alu	Kupfer, Messing, Zinn	Kunststoffe GFK/CFK	Hastelloy, Inconel, Exotische Materialien
Steel	Stainless	Grey cast iron	Alu	Copper, brass, tin	Plastics GRP/CRP	Hastelloy, Inconel, exotic materials
< 1400 N	> 900 N		> 10% Si			

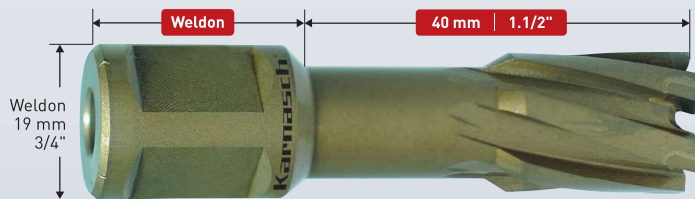

Zoll/Inch	Ø mm	Art.	Zoll/Inch	Ø mm	Art.	Zoll/Inch	Ø mm	Art.	Zoll/Inch	Ø mm	Art.
• 1/2"	12,70	20 1930 010	• 1"	25,40	20 1930 050	• 1.1/2"	38,10	20 1930 090	• 2"	50,80	20 1930 130
• 9/16"	14,28	20 1930 015	• 1.1/16"	26,98	20 1930 055	• 1.9/16"	39,68	20 1930 095	• 2.1/16"	52,38	20 1930 135
• 5/8"	15,87	20 1930 020	• 1.1/8"	28,57	20 1930 060	• 1.5/8"	41,27	20 1930 100			
• 11/16"	17,46	20 1930 025	• 1.3/16"	30,13	20 1930 065	• 1.11/16"	42,86	20 1930 105			
• 3/4"	19,04	20 1930 030	• 1.1/4"	31,75	20 1930 070	• 1.3/4"	44,45	20 1930 110			
• 13/16"	20,63	20 1930 035	• 1.5/16"	33,33	20 1930 075	• 1.13/16"	46,03	20 1930 115			
• 7/8"	22,22	20 1930 040	• 1.3/8"	34,92	20 1930 080	• 1.7/8"	47,62	20 1930 120			
• 15/16"	23,81	20 1930 045	• 1.7/16"	36,51	20 1930 085	• 1.15/16"	49,21	20 1930 125			

Achtung: Die Zollabmessungen entsprechen nicht exakt den mm Durchmessern.
Attention: The inch sizes do not correspond exactly to the mm diameters.

20 1930

HARD-LINE
ZOLL / INCH **40**

ZUBEHÖR • ACCESSORIES

AUSWERFERSTIFTE • EJECTOR PINS



1/2"-11/16" • 20 1149

Packnorm 2 Stk. · Packaging unit 2 pcs.



3/4"-2.1/16" • 20 1151

Packnorm 2 Stk. · Packaging unit 2 pcs.

20 1930

HARD-LINE
ZOLL / INCH **40**

SETS / DISPLAYS Seite / Page 556

Wir bieten eine große Auswahl an Sets / Displays – Inhaltsvorschläge 20 1930 HARD-LINE40 – siehe Seite 556. Anderer Inhalt auf Wunsch möglich, durch individuell bestückbare Sets / Displays.
We offer a large selection of sets / displays – recommended content 20 1930 HARD-LINE40 – see page 556. Other content possible by individually equipped sets / displays.



Schnittdaten
Cutting data

Film
Movie



1487

- 1
- 2
- 3
- 4
- 5
- 6
- 7
- 8
- 9
- 10

Zubehör für Hartmetall-bestückte Kernbohrer, Weldonschaft, Nutzlänge 40 mm
 Accessories for carbide-tipped annular cutter, Weldon shank, drill depth 40 mm | 1.1/2"

HARD-LINE 40 20 1930
 ZOLL / INCH

ADAPTER + PASSENDE AUSWERFERSTIFTE
ADAPTER + SUITABLE EJECTOR PINS

 FEIN Quick-In 18 mm
 Weldon + Nitto/Universal 19 mm 3/4"
 6,34 × 116 mm
 20 1263
 20 1318
 Packnorm 2 Stk. · Packaging unit 2 pcs.

 FEIN Quick-In 18 mm
 Weldon + Nitto/Universal 19 mm 3/4"
 7,98 × 118 mm
 20 1161
 20 1272
 Packnorm 2 Stk. · Packaging unit 2 pcs.

 Nitto/Universal 19 mm 3/4"
 Weldon 19 mm 3/4"
 6,34 × 116 mm
 20 1311
 20 1318
 Packnorm 2 Stk. · Packaging unit 2 pcs.

 Nitto/Universal 19 mm 3/4"
 Weldon 19 mm 3/4"
 7,98 × 118 mm
 20 1314
 20 1272
 Packnorm 2 Stk. · Packaging unit 2 pcs.

 Weldon 32 mm 1.1/4"
 Weldon + Nitto/Universal 19 mm 3/4"
 6,34 × 90 mm
 21 0048
 20 1149
 Packnorm 2 Stk. · Packaging unit 2 pcs.

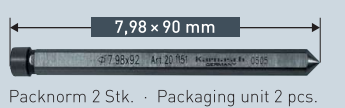
 7,98 × 90 mm
 20 1151
 Packnorm 2 Stk. · Packaging unit 2 pcs.

Ersatz-Innensechskantschrauben für alle Adapter siehe Seite 550
 Spare allen screws for all adapters see page 550

Weiteres Zubehör siehe Übersichtsseite 375
 Further accessories see overview page 375

VERLÄNGERUNGEN + PASSENDE AUSWERFERSTIFTE
EXTENSIONS + SUITABLE EJECTOR PINS

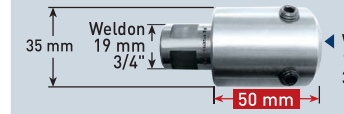
 Weldon 19 mm 3/4"
 Weldon + Nitto/Universal 19 mm 3/4"
 50 mm
 7,98 × 6,34 × 5,30 × 140 mm
 20 1387
 20 1390
 Packnorm 2 Stk. · Packaging unit 2 pcs.

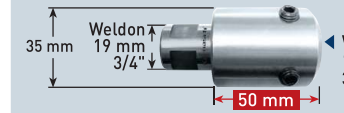
 Weldon 19 mm 3/4"
 Weldon + Nitto/Universal 19 mm 3/4"
 50 mm
 7,98 × 135 mm
 20 1387
 20 1393
 Packnorm 2 Stk. · Packaging unit 2 pcs.

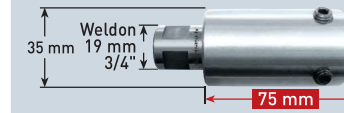
 Weldon 19 mm 3/4"
 Weldon + Nitto/Universal 19 mm 3/4"
 75 mm
 7,98 × 6,34 × 5,30 × 165 mm
 20 1402
 20 1405
 Packnorm 2 Stk. · Packaging unit 2 pcs.

 Weldon 19 mm 3/4"
 Weldon + Nitto/Universal 19 mm 3/4"
 75 mm
 7,98 × 167 mm
 20 1402
 20 1408
 Packnorm 2 Stk. · Packaging unit 2 pcs.

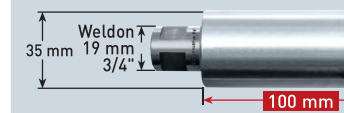
 Weldon 19 mm 3/4"
 Weldon + Nitto/Universal 19 mm 3/4"
 100 mm
 7,98 × 6,34 × 5,30 × 190 mm
 20 1417
 20 1420
 Packnorm 2 Stk. · Packaging unit 2 pcs.

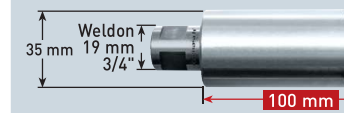
 Weldon 19 mm 3/4"
 Weldon + Nitto/Universal 19 mm 3/4"
 100 mm
 7,98 × 190 mm
 20 1417
 20 1423
 Packnorm 2 Stk. · Packaging unit 2 pcs.

Ersatz-Innensechskantschrauben für alle Verlängerungen siehe Seite 550
 Spare allen screws for all extensions see page 550

Weiteres Zubehör siehe Übersichtsseite 375
 Further accessories see overview page 375

- 1 
- 2 
- 3 
- 4 
- 5 
- 6 
- 7 
- 8 
- 9 
- 10 

20 1940

HARD-LINE
ZOLL / INCH **55**

Hartmetall-bestückter Kernbohrer, Weldonschaft, Nutzlänge 55 mm
Carbide-tipped annular cutter, Weldon shank, drill depth 55 mm | 2"



ANWENDUNG • APPLICATION

Stahl	Edelstahl	Grauguss	Alu	Kupfer, Messing, Zinn	Kunststoffe GFK/CFK	Hastelloy, Inconel, Exotische Materialien
Steel	Stainless	Grey cast iron	Alu	Copper, brass, tin	Plastics GRP/CRP	Hastelloy, Inconel, exotic materials
< 1400 N	> 900 N		> 10% Si			

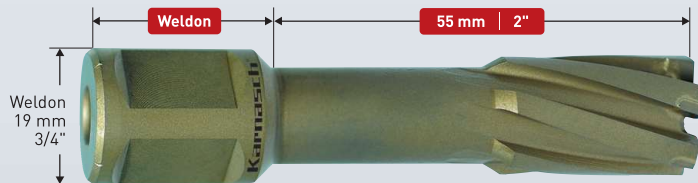

Zoll/Inch	Ø mm	Art.
• 1/2"	12,70	20 1940 010
• 9/16"	14,28	20 1940 015
• 5/8"	15,87	20 1940 020
• 11/16"	17,46	20 1940 025
• 3/4"	19,04	20 1940 030
• 13/16"	20,63	20 1940 035
• 7/8"	22,22	20 1940 040
• 15/16"	23,81	20 1940 045

Zoll/Inch	Ø mm	Art.
• 1"	25,40	20 1940 050
• 1.1/16"	26,98	20 1940 055
• 1.1/8"	28,57	20 1940 060
• 1.3/16"	30,13	20 1940 065
• 1.1/4"	31,75	20 1940 070
• 1.5/16"	33,33	20 1940 075
• 1.3/8"	34,92	20 1940 080
• 1.7/16"	36,51	20 1940 085

Zoll/Inch	Ø mm	Art.
• 1.1/2"	38,10	20 1940 090
• 1.9/16"	39,68	20 1940 095
• 1.5/8"	41,27	20 1940 100
• 1.11/16"	42,86	20 1940 105
• 1.3/4"	44,45	20 1940 110
• 1.13/16"	46,03	20 1940 115
• 1.7/8"	47,62	20 1940 120
• 1.15/16"	49,21	20 1940 125

Zoll/Inch	Ø mm	Art.
• 2"	50,80	20 1940 130
• 2.1/16"	52,38	20 1940 135

Achtung: Die Zollabmessungen entsprechen nicht exakt den mm Durchmessern.
Attention: The inch sizes do not correspond exactly to the mm diameters.

20 1940

HARD-LINE
ZOLL / INCH **55**

ZUBEHÖR • ACCESSORIES

AUSWERFERSTIFTE • EJECTOR PINS



1/2"-11/16" • 20 1271

Packnorm 2 Stk. • Packaging unit 2 pcs.



3/4"-2.1/16" • 20 1273

Packnorm 2 Stk. • Packaging unit 2 pcs.

20 1940

HARD-LINE
ZOLL / INCH **55**

SETS / DISPLAYS Seite / Page 557

Wir bieten eine große Auswahl an Sets / Displays – Inhaltsvorschläge 20 1940 HARD-LINE55 – siehe Seite 557. Anderer Inhalt auf Wunsch möglich, durch individuell bestückbare Sets / Displays.
We offer a large selection of sets / displays – recommended content 20 1940 HARD-LINE55 – see page 557. Other content possible by individually equipped sets / displays.



Schnittdaten
Cutting data

Film
Movie



1487

- 1
- 2
- 3
- 4
- 5
- 6
- 7
- 8
- 9
- 10
- Index

Zubehör für Hartmetall-bestückte Kernbohrer, Weldonschaft, Nutzlänge 55 mm
 Accessories for carbide-tipped annular cutter, Weldon shank, drill depth 55 mm | 2"

HARD-LINE 55 20 1940
 ZOLL / INCH

ADAPTER + PASSENDE AUSWERFERSTIFTE
ADAPTER + SUITABLE EJECTOR PINS

 FEIN Quick-In 18 mm
 Weldon + Nitto/Universal 19 mm 3/4"

 6,34 x 130 mm

Packnorm 2 Stk. · Packaging unit 2 pcs. **20 1263** **20 1160**

 FEIN Quick-In 18 mm
 Weldon + Nitto/Universal 19 mm 3/4"

 7,98 x 130 mm

Packnorm 2 Stk. · Packaging unit 2 pcs. **20 1161** **20 1439**

 Nitto/Universal 19 mm 3/4"
 Weldon 19 mm 3/4"

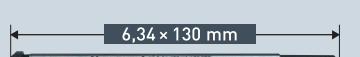
 6,34 x 130 mm

Packnorm 2 Stk. · Packaging unit 2 pcs. **20 1311** **20 1160**

 Nitto/Universal 19 mm 3/4"
 Weldon 19 mm 3/4"

 7,98 x 130 mm

Packnorm 2 Stk. · Packaging unit 2 pcs. **20 1314** **20 1439**

 Weldon 32 mm 1.1/4"
 Weldon + Nitto/Universal 19 mm 3/4"

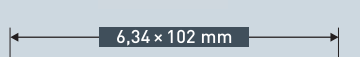
 6,34 x 102 mm

Packnorm 2 Stk. · Packaging unit 2 pcs. **21 0048** **20 1271**

 Weldon 32 mm 1.1/4"
 Weldon + Nitto/Universal 19 mm 3/4"

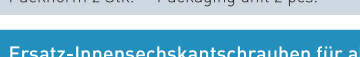
 7,98 x 105 mm

Packnorm 2 Stk. · Packaging unit 2 pcs. **20 1273**

Ersatz-Innensechskantschrauben für alle Adapter siehe Seite 550
 Spare allen screws for all adapters see page 550

Weiteres Zubehör siehe Übersichtsseite 375
 Further accessories see overview page 375

VERLÄNGERUNGEN + PASSENDE AUSWERFERSTIFTE
EXTENSIONS + SUITABLE EJECTOR PINS

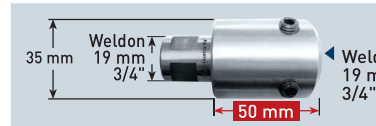
 Weldon 19 mm 3/4"
 Weldon + Nitto/Universal 19 mm 3/4"

 7,98 x 6,34 x 5,30 x 153 mm

Packnorm 2 Stk. · Packaging unit 2 pcs. **20 1387** **20 1396**

 Weldon 19 mm 3/4"
 Weldon + Nitto/Universal 19 mm 3/4"

 7,98 x 160 mm

Packnorm 2 Stk. · Packaging unit 2 pcs. **20 1387** **20 1399**

 Weldon 19 mm 3/4"
 Weldon + Nitto/Universal 19 mm 3/4"

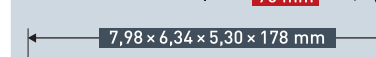
 7,98 x 6,34 x 5,30 x 178 mm

Packnorm 2 Stk. · Packaging unit 2 pcs. **20 1402** **20 1411**

 Weldon 19 mm 3/4"
 Weldon + Nitto/Universal 19 mm 3/4"

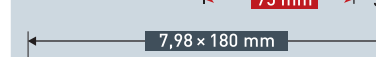
 7,98 x 180 mm

Packnorm 2 Stk. · Packaging unit 2 pcs. **20 1402** **20 1414**

 Weldon 19 mm 3/4"
 Weldon + Nitto/Universal 19 mm 3/4"

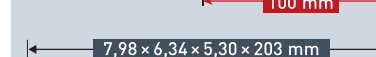
 7,98 x 6,34 x 5,30 x 203 mm

Packnorm 2 Stk. · Packaging unit 2 pcs. **20 1417** **20 1426**

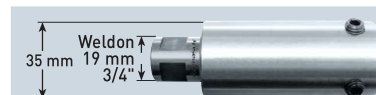
 Weldon 19 mm 3/4"
 Weldon + Nitto/Universal 19 mm 3/4"

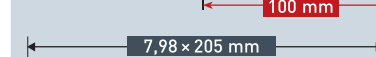
 7,98 x 205 mm

Packnorm 2 Stk. · Packaging unit 2 pcs. **20 1417** **20 1429**

Ersatz-Innensechskantschrauben für alle Verlängerungen siehe Seite 550
 Spare allen screws for all extensions see page 550

Weiteres Zubehör siehe Übersichtsseite 375
 Further accessories see overview page 375



20 1970

HARD-LINE
ZOLL / INCH **80**

Hartmetall-bestückter Kernbohrer, Weldonchaft, Nutzlänge 80 mm
Carbide-tipped annular cutter, Weldon shank, drill depth 80 mm | 3"



ANWENDUNG • APPLICATION

Stahl	Edelstahl	Grauguss	Alu	Kupfer, Messing, Zinn	Kunststoffe GFK/CFK	Hastelloy, Inconel, Exotische Materialien
Steel	Stainless	Grey cast iron	Alu	Copper, brass, tin	Plastics GRP/CRP	Hastelloy, Inconel, exotic materials
< 1400 N	> 900 N		> 10% Si			



Zoll/Inch	Ø mm	Art.	Zoll/Inch	Ø mm	Art.	Zoll/Inch	Ø mm	Art.	Zoll/Inch	Ø mm	Art.
• 11/16"	17,46	20 1970 025	• 1.1/16"	26,98	20 1970 055	• 1.7/16"	36,51	20 1970 085	• 1.13/16"	46,03	20 1970 115
• 3/4"	19,04	20 1970 030	• 1.1/8"	28,57	20 1970 060	• 1.1/2"	38,10	20 1970 090	• 1.7/8"	47,62	20 1970 120
• 13/16"	20,63	20 1970 035	• 1.3/16"	30,13	20 1970 065	• 1.9/16"	39,68	20 1970 095	• 1.15/16"	49,21	20 1970 125
• 7/8"	22,22	20 1970 040	• 1.1/4"	31,75	20 1970 070	• 1.5/8"	41,27	20 1970 100	• 2"	50,80	20 1970 130
• 15/16"	23,81	20 1970 045	• 1.5/16"	33,33	20 1970 075	• 1.11/16"	42,86	20 1970 105	• 2.1/16"	52,38	20 1970 135
• 1"	25,40	20 1970 050	• 1.3/8"	34,92	20 1970 080	• 1.3/4"	44,45	20 1970 110			

Achtung: Die Zollabmessungen entsprechen nicht exakt den mm Durchmessern.
Attention: The inch sizes do not correspond exactly to the mm diameters.

20 1970

HARD-LINE
ZOLL / INCH **80**

ZUBEHÖR • ACCESSORIES



AUSWERFERSTIFTE 1-TEILIG • EJECTOR PINS 1-PIECE

• 20 1439



1-teilig / 1 piece

Packnorm 2 Stk. · Packaging unit 2 pcs.

Zusammen mit Aufnahmehalter 20 1842, 20 1291, 20 1843, 20 1845, 20 1846 (siehe Seite 542–543) kann dieser einteilige Auswerferstift verwendet werden. Es kann ohne Umstecken bis 110 mm Schnitttiefe in einem Arbeitsgang gebohrt werden. Robust und einfach.

It is possible to use this one-piece ejector pin in combination with tool holder article 20 1842, 20 1291, 20 1843, 20 1845, 20 1846 (see page 542–543). You can drill as deep as 110 mm in one working process without changing. Robust and easy.

AUSWERFERSTIFTE 2-TEILIG EJECTOR PINS 2-PIECE

• 20 1427



2-teilig / 2 piece

Packnorm 2 Stk. · Packaging unit 2 pcs.

ANWENDUNG AUSWERFERSTIFTE 2-TEILIG APPLICATION EJECTOR PINS 2-PIECE



Anwendung:

Teil 1 in den Schaft des Kernbohrers einführen. Teil 2 auf Teil 1 schieben. Bohren Sie bis ca. 50 mm Schnitttiefe. Danach Teil 2 entfernen und weiter bohren.

Application:

Insert piece 1 into the annular cutter shank. Push piece 2 onto part 1. Drill as deep as 50 mm cutting depth. Then remove piece 2 and continue drilling.

• **Warum 2-teilige Auswerferstifte?** In der Regel haben Standard Morsekonus-Aufnahmehalter eine Schnitttiefenkapazität von 50 mm. Wenn **keine extra langen** Aufnahmehalter verwendet werden (wie auf Seite 542–543 Art. 20 1842, 20 1291, 20 1843, 20 1845, 20 1846), müssen bei Schnitttiefen über 50 mm 2-teilige Auswerferstifte verwendet werden.

• **Why use 2-part ejector pins?** Usually, standard morse taper holders have a cutting depth capacity of 50 mm. If **no extra-long** holders are used (e.g. as on page 542–543 Art. 20 1842, 20 1291, 20 1843, 20 1845, 20 1846), you need for drill depths above 50 mm 2-part ejector pins.

Schnittdaten
Cutting data

Film
Movie



1487



1
2
3
4
5
6
7
8
9
10
Index

Zubehör für Hartmetall-bestückte Kernbohrer, Weldonschaft, Nutzlänge 80 mm
 Accessories for carbide-tipped annular cutter, Weldon shank, drill depth 80 mm | 3"

HARD-LINE 80 20 1970
 ZOLL / INCH

ADAPTER + PASSENDE AUSWERFERSTIFTE
ADAPTER + SUITABLE EJECTOR PINS

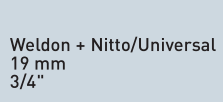
FEIN Quick-In 18 mm  **Weldon + Nitto/Universal 19 mm 3/4"** 

20 1161

7,98 x 157 mm  **20 1436**

1 2-teilig / 2 piece 2

Packnorm 2 Stk. · Packaging unit 2 pcs.

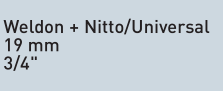
Weldon 32 mm 1.1/4"  **Weldon + Nitto/Universal 19 mm 3/4"** 

21 0048

7,98 x 130 mm  **20 1439**

1-teilig / 1 piece

Packnorm 2 Stk. · Packaging unit 2 pcs.

7,98 x 130 mm  **20 1427**

1 2-teilig / 2 piece 2

Packnorm 2 Stk. · Packaging unit 2 pcs.

Ersatz-Innensechskantschrauben für alle Adapter siehe Seite 550
 Spare allen screws for all adapters see page 550

ZUBEHÖR · SETS · DISPLAYS · ERSATZTEILE / ACCESSORIES · SETS · DISPLAYS · SPARE PARTS

Aufnahmehalter mit Morsekonus 2 / 3 / 4 / 5 und Reduzierhülsen  **541-543**
 Tool holders with morse taper 2 / 3 / 4 / 5 and reduction sleeves

Kühlmittel-Druckflaschen  **548**
 Coolant pressure bottles

Kegelsenker mit Weldonschaft  **544/545**
 Countersinks with Weldon shank

Magnetstab zur Entfernung der Bohrspäne  **549**
 Magnetic stick for chip removal

Spiralbohradapter Weldon + Spiralbohrer Ø 2,5-12 mm  **648**
 Twist drill adaptors Weldon + twist drills Ø 2,5-12 mm

Sets · Displays  **553-582**
 Sets · Displays

Gewindeadapter Weldon + Gewindebohrer M 3 - M 30  **649-650**
 Tapping adapter Weldon + taps M 3 - M 30

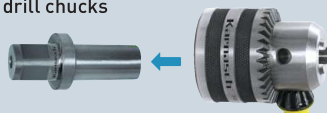
Adapter + passende Bohrfutter  **548**
 Adapters + suitable drill chucks

Ersatzteile  **550-552**
 Spare parts

- 1 
- 2 
- 3 
- 4 
- 5 
- 6 
- 7 
- 8 
- 9 
- 10 **Index**

HARDOX / HARTE STÄHLE KERNBOHRER HARDOX / HARD STEEL ANNULAR CUTTER



HARDOX-LINE

Der beste Kernbohrer zum Bohren in:

- Hardox 400, 450, 500
- Harte Stähle ab 30 HRC bis 50 HRC

Speziell entwickeltes Hartmetall sowie optimierte Geometrie ergeben exzellente Ergebnisse beim Bohren von HARDOX / HARTE STÄHLE (unbedingt Schnittparameter beachten).

The best annular cutter for drilling in:

- Hardox 400, 450, 500
- Hard steels from 30 HRC up to 50 HRC

Specially developed carbide as well as optimized geometry results in excellent performance for drilling in HARDOX / HARD STEEL (absolutely observe cutting parameters).

EIGENSCHAFTEN · PROPERTIES



Karnasch HARDOX-LINE Kernbohrer werden mit konischer Spirale gefertigt für sauberen Spanfluss und höchste Zerspanleistung.

Karnasch HARDOX-LINE annular cutters are made with a conical helix for clean chip flow and highest cutting ability.



Karnasch HARDOX-LINE Kernbohrer kommen mit optimiertem Hartmetall zum Bohren in HARDOX und HARTE STÄHLE.

Karnasch HARDOX-LINE annular cutters come with optimized carbide tipped teeth for excellent results drilling in HARDOX and HARD STEEL.



Karnasch HARDOX-LINE Kernbohrer sind in einer aufwendigen Vor-Mittel-Nachschneider-Geometrie gefertigt. Dies ergibt: ratterfreies, ruhiges und leichtes Zerspanen mit höchsten Standzeiten.

Karnasch HARDOX-LINE annular cutters are made in an elaborate pre-/ intermediate-/ after-cutting geometry. This results in: clatter-free, silent and easy cutting with highest lifetimes.

ANWENDUNG · APPLICATION



Hardox
400, 450, 500

Hardox
400, 450, 500



Harter Stahl
ab 30 HRC
bis 50 HRC

Hard steel
from 30 HRC
up to 50 HRC



ACHTUNG:

Maximal empfohlene Schnitttiefe bei Hardox:
Art. 20 1680 = 20 mm
Art. 20 1690 = 35 mm
Unbedingt Schnittparameter beachten,
siehe Seite 1490-1491

ATTENTION:

Maximum recommended cutting depth for
Hardox:
Art. 20 1680 = 20 mm
Art. 20 1690 = 35 mm
Be sure to observe cutting parameters,
see page 1490-1491



OPTIMAL · OPTIMAL



GUT · GOOD



MÖGLICH · POSSIBLE

HARDOX / HARTE STÄHLE KERNBOHRER HARDOX / HARD STEEL ANNULAR CUTTER

HARDOX-LINE

Schnitttiefe · Drill depths

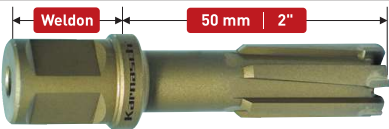
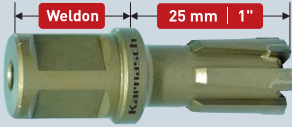

Ø mm	Ø Zoll/Inch	Art. / Type	
14-40	35/64-1.37/64"	20 1680 HARDOX-LINE /25	400
14-60	35/64-2.23/64"	20 1690 HARDOX-LINE /50	402

Größere Ø und Schnitttiefen auf Anfrage · Larger Ø and drill depths on request

ZUBEHÖR · SETS · DISPLAYS · ERSATZTEILE / ACCESSORIES · SETS · DISPLAYS · SPARE PARTS

Aufnahmehalter mit Morsekonus 2 / 3 / 4 / 5 und Reduzierhülsen 541-543
Tool holders with morse taper 2 / 3 / 4 / 5 and reduction sleeves



Kegelsenker 693
Countersinks

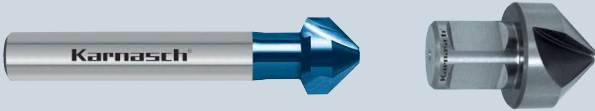

Spiralbohradapter Weldon + Spiralbohrer Ø 2,5-12 mm 648
Twist drill adaptors Weldon + twist drills Ø 2,5-12 mm



Gewindeadapter Weldon + Gewindebohrer M 3 - M 30 649-650
Tapping adapter Weldon + taps M 3 - M 30



Vollhartmetall Gewindebohrer-Ausbohrer 652
Solid carbide drills to remove jammed taps



Adapter + passende Bohrfutter 548
Adapters + suitable drill chucks

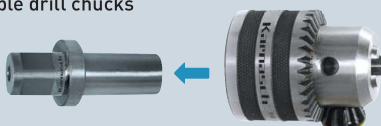

Kühlmittel-Druckflaschen 548
Coolant pressure bottles



Magnetstab zur Entfernung der Bohrspäne 549
Magnetic stick for chip removal



Sets · Displays 553-582
Sets · Displays



Ersatzteile 550-552
Spare parts

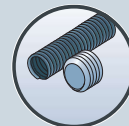

- 1
- 2
- 3
- 4
- 5
- 6
- 7
- 8
- 9
- 10

20 1680

HARDOX-LINE 25

Hartmetall-bestückter Kernbohrer, Weldonschaft, Nutzlänge 25 mm
Carbide-tipped annular cutter, Weldon shank, drill depth 25 mm | 1"



ANWENDUNG • APPLICATION



Hardox
400, 450, 500



Harter Stahl
ab 30 HRC bis
50 HRC

Hard steel
from 30 HRC up
to 50 HRC

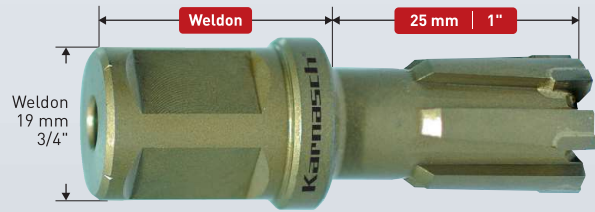

Art.	Ø mm	Ø Zoll Inch	Art.	Ø mm	Ø Zoll Inch	Art.	Ø mm	Ø Zoll Inch	Art.	Ø mm	Ø Zoll Inch
20 1680 014	• 14	35/64"	20 1680 022	• 22	55/64"	20 1680 030	• 30	1.3/16"	20 1680 038	• 38	1.1/2"
20 1680 015	• 15	19/32"	20 1680 023	• 23	29/32"	20 1680 031	• 31	1.7/32"	20 1680 039	• 39	1.17/32"
20 1680 016	• 16	5/8"	20 1680 024	• 24	15/16"	20 1680 032	• 32	1.17/64"	20 1680 040	• 40	1.37/64"
20 1680 017	• 17	43/64"	20 1680 025	• 25	63/64"	20 1680 033	• 33	1.19/64"			
20 1680 018	• 18	45/64"	20 1680 026	• 26	1.1/32"	20 1680 034	• 34	1.11/32"			
20 1680 019	• 19	3/4"	20 1680 027	• 27	1.1/16"	20 1680 035	• 35	1.3/8"			
20 1680 020	• 20	25/32"	20 1680 028	• 28	1.7/64"	20 1680 036	• 36	1.27/64"			
20 1680 021	• 21	53/64"	20 1680 029	• 29	1.9/64"	20 1680 037	• 37	1.29/64"			

Größere Ø siehe Art. 20 1690 Seite 402 · Maximal empfohlene Schnitttiefe bei Hardox = 20 mm ·
Achtung: Die Zollabmessungen entsprechen nicht exakt den mm Durchmessern.

Larger Ø see Art. 20 1690 page 402 · Maximum recommended cutting depth for Hardox = 20 mm ·
Attention: The inch sizes do not correspond exactly to the mm diameters.

20 1680

HARDOX-LINE 25

ZUBEHÖR • ACCESSORIES



AUSWERFERSTIFTE • EJECTOR PINS

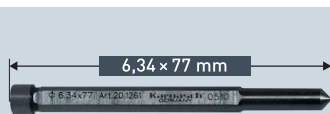

Ø 12-40 mm • 20 1261

Packnorm 2 Stk. · Packaging unit 2 pcs.

SETS / DISPLAYS

• 20 1344

• 20 1138

• 20 1132

• 20 1139



max. 44 Stück / Pieces

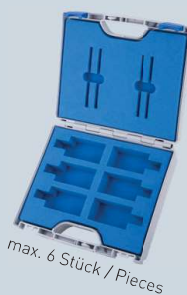

max. 6 Stück / Pieces

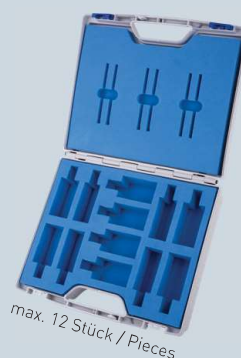

max. 12 Stück / Pieces



max. 50 Stück / Pieces

Sie möchten Ihren Inhalt selbst aussuchen?
Kein Problem. Kontaktieren Sie uns und wir stellen Ihr Wunsch-Set oder Wunsch-Display zusammen.

Would you like to select your own contents?
No Problem. Contact us and we create your individual set or display.

Schnittdaten
Cutting data

Film
Movie



1490-1491

Zubehör für Hartmetall-bestückte Kernbohrer, Weldonschaft, Nutzlänge 25 mm
 Accessories for carbide-tipped annular cutter, Weldon shank, drill depth 25 mm | 1"

HARDOX-LINE 25 20 1680

ADAPTER + PASSENDE AUSWERFERSTIFTE
ADAPTER + SUITABLE EJECTOR PINS

FEIN Quick-In 18 mm

Weldon+Nitto/Universal 19 mm 3/4"

6,34 x 102 mm

• 20 1263

• 20 1271

Packnorm 2 Stk. · Packaging unit 2 pcs.

Nitto/Universal 19 mm 3/4"

Weldon 19 mm 3/4"

6,34 x 102 mm

• 20 1311

• 20 1271

Packnorm 2 Stk. · Packaging unit 2 pcs.

Weldon 32 mm 1.1/4"

Weldon + Nitto/Universal 19 mm 3/4"

6,34 x 77 mm

• 21 0048

• 20 1261

Packnorm 2 Stk. · Packaging unit 2 pcs.

Ersatz-Innensechskantschrauben für alle Adapter siehe Seite 550
 Spare allen screws for all adapters see page 550

VERLÄNGERUNGEN + PASSENDE AUSWERFERSTIFTE
EXTENSIONS + SUITABLE EJECTOR PINS

Weldon 19 mm 3/4"

Weldon+Nitto/Universal 19 mm 3/4"

7,98 x 6,34 x 5,30 x 127 mm

50 mm

• 20 1387

• 20 1433

Packnorm 2 Stk. · Packaging unit 2 pcs.

Weldon 19 mm 3/4"

Weldon+Nitto/Universal 19 mm 3/4"

7,98 x 6,34 x 5,30 x 153 mm

75 mm

• 20 1402

• 20 1396

Packnorm 2 Stk. · Packaging unit 2 pcs.

Weldon 19 mm 3/4"

Weldon+Nitto/Universal 19 mm 3/4"

7,98 x 6,34 x 5,30 x 178 mm

100 mm

• 20 1417

• 20 1411

Packnorm 2 Stk. · Packaging unit 2 pcs.

Ersatz-Innensechskantschrauben für alle Verlängerungen siehe Seite 550
 Spare allen screws for all extensions see page 550

Weiteres Zubehör siehe Übersichtsseite 509
 Further accessories see overview page 509



20 1690

HARDOX-LINE 50

Hartmetall-bestückter Kernbohrer, Weldonschaft, Nutzlänge 50 mm
Carbide-tipped annular cutter, Weldon shank, drill depth 50 mm | 2"



ANWENDUNG • APPLICATION



Hardox
400, 450, 500



Harter Stahl
ab 30 HRC bis
50 HRC

Hardox
400, 450, 500

Hard steel
from 30 HRC up
to 50 HRC

📌 Sonderpreis / Sale Artikel. Lieferbar solange Vorrat.
Special price / sale article. While stocks last.

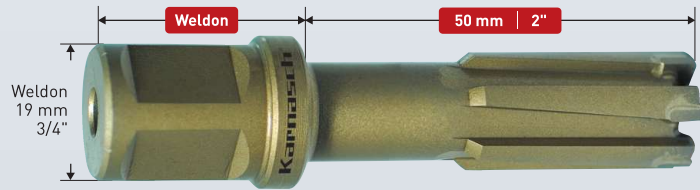

Art.	Ø mm	Ø Zoll Inch	Art.	Ø mm	Ø Zoll Inch	Art.	Ø mm	Ø Zoll Inch	Art.	Ø mm	Ø Zoll Inch
20 1690 014	• 14	35/64"	20 1690 026	• 26	1.1/32"	20 1690 038	• 38	1.1/2"	20 1690 050	• 50	1.31/32"
20 1690 015	• 15	19/32"	20 1690 027	• 27	1.1/16"	20 1690 039	• 39	1.17/32"	20 1690 051	• 51	2.1/64"
20 1690 016	• 16	5/8"	20 1690 028	• 28	1.7/64"	20 1690 040	• 40	1.37/64"	20 1690 052	• 52	2.3/64"
20 1690 017	• 17	43/64"	20 1690 029	• 29	1.9/64"	20 1690 041	• 41	1.39/64"	20 1690 053	📌 53	2.3/32"
20 1690 018	• 18	45/64"	20 1690 030	• 30	1.3/16"	20 1690 042	• 42	1.21/32"	20 1690 054	• 54	2.1/8"
20 1690 019	• 19	3/4"	20 1690 031	• 31	1.7/32"	20 1690 043	• 43	1.11/16"	20 1690 055	• 55	2.11/64"
20 1690 020	• 20	25/32"	20 1690 032	• 32	1.17/64"	20 1690 044	• 44	1.47/64"	20 1690 056	• 56	2.13/64"
20 1690 021	• 21	53/64"	20 1690 033	• 33	1.19/64"	20 1690 045	• 45	1.49/64"	20 1690 057	📌 57	2.1/4"
20 1690 022	• 22	55/64"	20 1690 034	• 34	1.11/32"	20 1690 046	• 46	1.13/16"	20 1690 058	📌 58	2.9/32"
20 1690 023	• 23	29/32"	20 1690 035	• 35	1.3/8"	20 1690 047	• 47	1.27/32"	20 1690 059	• 59	2.21/64"
20 1690 024	• 24	15/16"	20 1690 036	• 36	1.27/64"	20 1690 048	• 48	1.57/64"	20 1690 060	• 60	2.23/64"
20 1690 025	• 25	63/64"	20 1690 037	• 37	1.29/64"	20 1690 049	• 49	1.59/64"			

Maximal empfohlene Schnitttiefe bei Hardox = 35 mm • **Achtung:** Die Zollabmessungen entsprechen nicht exakt den mm Durchmessern.

Maximum recommended cutting depth for Hardox = 35 mm • **Attention:** The inch sizes do not correspond exactly to the mm diameters.

20 1690

HARDOX-LINE 50

ZUBEHÖR • ACCESSORIES



AUSWERFERSTIFTE • EJECTOR PINS

📌 Ø 14-60 mm • 20 1271



Packnorm 2 Stk. • Packaging unit 2 pcs.

SETS / DISPLAYS

📌 • 20 1344

📌 • 20 1138

📌 • 20 1132

📌 • 20 1139



max. 44 Stück / Pieces

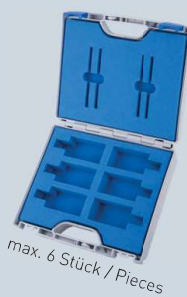

max. 6 Stück / Pieces

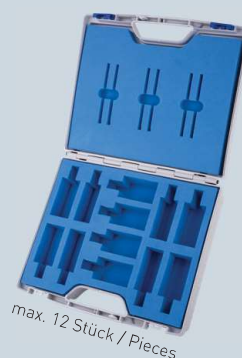

max. 12 Stück / Pieces



max. 50 Stück / Pieces

Sie möchten Ihren Inhalt selbst aussuchen?

Kein Problem. Kontaktieren Sie uns und wir stellen Ihr Wunsch-Set oder Wunsch-Display zusammen.

Would you like to select your own contents?

No Problem. Contact us and we create your individual set or display.

Schnittdaten
Cutting data

Film
Movie



1490-1491

Zubehör für Hartmetall-bestückte Kernbohrer, Weldonschaft, Nutzlänge 50 mm
 Accessories for carbide-tipped annular cutter, Weldon shank, drill depth 50 mm | 2"

HARDOX-LINE 50 20 1690

ADAPTER + PASSENDE AUSWERFERSTIFTE
ADAPTER + SUITABLE EJECTOR PINS

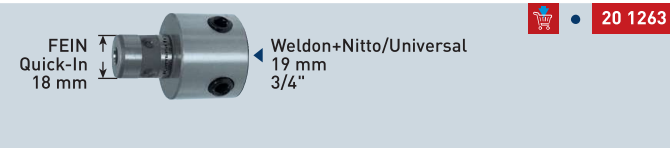

FEIN Quick-In 18 mm
 Weldon+Nitto/Universal 19 mm 3/4"

6,34 × 130 mm

Packnorm 2 Stk. · Packaging unit 2 pcs.

20 1263



Nitto/Universal 19 mm 3/4"
 Weldon 19 mm 3/4"

6,34 × 130 mm

Packnorm 2 Stk. · Packaging unit 2 pcs.

20 1311

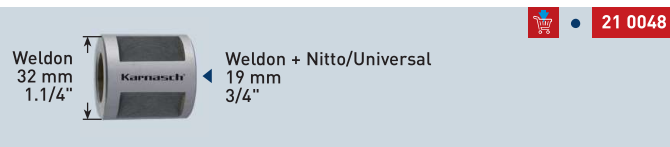

Weldon 32 mm 1.1/4"
 Weldon + Nitto/Universal 19 mm 3/4"

6,34 × 102 mm

Packnorm 2 Stk. · Packaging unit 2 pcs.

21 0048

Ersatz-Innensechskantschrauben für alle Adapter siehe Seite 550
 Spare allen screws for all adapters see page 550

VERLÄNGERUNGEN + PASSENDE AUSWERFERSTIFTE
EXTENSIONS + SUITABLE EJECTOR PINS



35 mm Weldon 19 mm 3/4"
 Weldon+Nitto/Universal 19 mm 3/4"

50 mm

7,98 × 6,34 × 5,30 × 153 mm

Packnorm 2 Stk. · Packaging unit 2 pcs.

20 1387



35 mm Weldon 19 mm 3/4"
 Weldon+Nitto/Universal 19 mm 3/4"

75 mm

7,98 × 6,34 × 5,30 × 178 mm

Packnorm 2 Stk. · Packaging unit 2 pcs.

20 1402



35 mm Weldon 19 mm 3/4"
 Weldon+Nitto/Universal 19 mm 3/4"

100 mm

7,98 × 6,34 × 5,30 × 203 mm

Packnorm 2 Stk. · Packaging unit 2 pcs.

20 1417

Ersatz-Innensechskantschrauben für alle Verlängerungen siehe Seite 550
 Spare allen screws for all extensions see page 550

Weiteres Zubehör siehe Übersichtsseite 509
 Further accessories see overview page 509



PULVERSTAHL + DURABLU- BESCHICHTETE KERNBOHRER POWDER STEEL + DURABLU-COATED ANNULAR CUTTERS



BLUE-DRILL LINE PRO

Neben Hartmetall-bestückten Kernbohrern bieten beschichtete Pulverstahl-Kernbohrer ein hervorragendes Preis-Leistungs-Verhältnis.

Im harten Einsatz kann nur in den seltensten Fällen auf optimale Drehzahlen und Kühlung Rücksicht genommen werden. Die Karnasch DURABLU-Beschichtung macht den Kernbohrer somit entscheidend widerstandsfähiger. Letztendlich wird dadurch die Lebensdauer des Bohrers wesentlich erhöht.

BLUE-DRILL LINE PRO Kernbohrer sind der Problemlöser für schwierigste Zerspanungsprobleme. Bohren in Stähle bis 45 Rockwell (HRC). (Als beschichtete Standardkernbohrer empfehlen wir unsere BLUE-DRILL LINE Versionen siehe Seite 411)

Carbide tipped annular cutters and coated powder steel cutters provide an excellent price-performance ratio.

The Karnasch DURABLU-coating makes the annular cutter decisively more resistant. This results in a considerable increase of product life.

BLUE-DRILL LINE PRO annular cutters are the right choice for most difficult materials. Drilling in steel up to 45 Rockwell (HRC). (For standard coated annular cutters we recommend our BLUE-DRILL LINE range see page 411)

EIGENSCHAFTEN · PROPERTIES



Gefertigt aus ASP Pulverstahl zum Bohren auch schwierigster Materialien wie Eisenbahnschienen, Edelstähle, exotische Legierungen. Immer dort einsetzbar wo höchste Verschleißfestigkeit und Standzeit benötigt wird.

Made of ASP powder steel for drilling of difficult materials like railway tracks, stainless steels, exotic alloys. Applicable wherever a high wear resistance and lifetime are required.

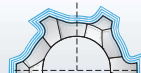

Unsere hochwertigsten Kernbohrer erhalten die einzigartige und patentierte DURABLU-Beschichtung. Extreme Oberflächenhärte- und -glätte ergeben extreme Standzeiten auch unter nicht optimalen Arbeitsbedingungen wie „Über Kopf arbeiten“, Trockenbohrungen, u.s.w.

Our first-class annular cutters are equipped with the unique and patented DURABLU-coating. Extreme surface hardness and sleekness yield extreme lifetimes even under non-optimum conditions like "overhead work", dry drilling, etc.



Nur wenige Hersteller sind in der Lage in Stufen gehärtete Kernbohrer zu fertigen. Für uns ist dies „Standard“. Dadurch erreichen wir extrem harte Zahnschneiden (68 HRC) und dennoch einen flexiblen Kernbohrer.

Only few manufacturers are capable of producing step-hardened annular cutters. For Karnasch this is "standard". Only this makes us produce extremely hard tooth tips (68 HRC) and yet a flexible annular cutter.

ANWENDUNG · APPLICATION

Stahl	Stahl	Edelstahl	Alu	Kupfer, Messing, Zinn	Kunststoffe GFK/CFK	Grauguss	Hastelloy, Inconel, Nimonic, Exotische Materialien	Schienen	Hardox 400	Hardox 450
Steel	Steel	Stainless	Alu	Copper, brass, tin	Plastics GRP/CRP	Grey cast iron	Hastelloy, Inconel, Nimonic, exotic materials	Rails	Hardox 400	Hardox 450
< 1100 N	< 1400 N	> 900 N	> 10% Si							
✓	✓	✓	✓	✓	✓	✓	✓	✓	✓	✓

✓ OPTIMAL · OPTIMAL

✓ GUT · GOOD

✓ MÖGLICH · POSSIBLE

PULVERSTAHL + DURABLU-ESCHICHTETE KERNBOHRER POWDER STEEL + DURABLU-COATED ANNULAR CUTTERS

BLUE-DRILL LINE PRO

Schnitttiefe · Drill depths

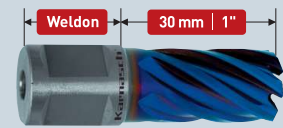

Ø mm

Ø Zoll/Inch

Art. / Type



12-36

15/32-
1.27/64"

20 1284

BLUE-DRILL LINE **30**
PRO

406



12-36

15/32-
1.27/64"

20 1317

BLUE-DRILL LINE **55**
PRO

408

ZUBEHÖR · SETS · DISPLAYS · ERSATZTEILE / ACCESSORIES · SETS · DISPLAYS · SPARE PARTS

Aufnahmehalter mit Morsekonus 2 / 3 / 4 / 5 und Reduzierhülsen 541-543

Tool holders with morse taper 2 / 3 / 4 / 5 and reduction sleeves



Kühlmittel-Druckflaschen 548

Coolant pressure bottles



Kegelsenker mit Weldonschaft 544/545

Countersinks with Weldon shank

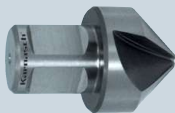

Magnetstab zur Entfernung der Bohrspäne 549

Magnetic stick for chip removal



Spiralbohradapter Weldon + Spiralbohrer Ø 2,5-12 mm 648

Twist drill adaptors Weldon + twist drills Ø 2,5-12 mm



Sets · Displays 553-582

Sets · Displays



Gewindeadapter Weldon + Gewindebohrer M 3 - M 30 649-650

Tapping adapter Weldon + taps M 3 - M 30



Vollhartmetall Gewindebohrer-Ausbohrer 652

Solid carbide drills to remove jammed taps



Adapter + passende Bohrfutter 548

Adapters + suitable drill chucks

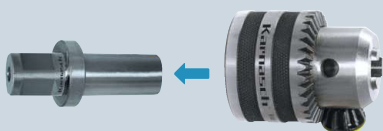

Ersatzteile 550-552

Spare parts

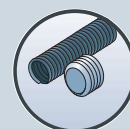

- 1
- 2
- 3
- 4
- 5
- 6
- 7
- 8
- 9
- 10

20 1284

BLUE-DRILL LINE 30 PRO

Pulverstahl + DURABLU-beschichteter Kernbohrer, Weldonschaft, Nutzlänge 30 mm
 Powder steel + DURABLU-coated annular cutter, Weldon shank, drill depth 30 mm | 1"



ANWENDUNG • APPLICATION

Stahl	Edelstahl	Grauguss	Alu	Kupfer, Messing, Zinn	Kunststoffe GFK/CFK	Hastelloy, Inconel, Exotische Materialien	Hardox 400, 450
Steel	Stainless	Grey cast iron	Alu	Copper, brass, tin	Plastics GRP/CRP	Hastelloy, Inconel, exotic materials	Hardox 400, 450
< 1400 N	> 900 N		> 10% Si				

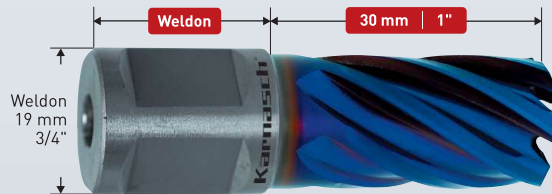

Art.	Ø mm	Ø Zoll Inch	Art.	Ø mm	Ø Zoll Inch	Art.	Ø mm	Ø Zoll Inch	Art.	Ø mm	Ø Zoll Inch
20 1284 012	• 12	15/32"	20 1284 020	• 20	25/32"	20 1284 028	• 28	1.7/64"	20 1284 036	• 36	1.27/64"
20 1284 013	• 13	33/64"	20 1284 021	• 21	53/64"	20 1284 029	• 29	1.9/64"			
20 1284 014	• 14	35/64"	20 1284 022	• 22	55/64"	20 1284 030	• 30	1.3/16"			
20 1284 015	• 15	19/32"	20 1284 023	• 23	29/32"	20 1284 031	• 31	1.7/32"			
20 1284 016	• 16	5/8"	20 1284 024	• 24	15/16"	20 1284 032	• 32	1.17/64"			
20 1284 017	• 17	43/64"	20 1284 025	• 25	63/64"	20 1284 033	• 33	1.19/64"			
20 1284 018	• 18	45/64"	20 1284 026	• 26	1.1/32"	20 1284 034	• 34	1.11/32"			
20 1284 019	• 19	3/4"	20 1284 027	• 27	1.1/16"	20 1284 035	• 35	1.3/8"			

Achtung: Die Zollabmessungen entsprechen nicht exakt den mm Durchmessern.
Attention: The inch sizes do not correspond exactly to the mm diameters.

20 1284

BLUE-DRILL LINE 30 PRO

ZUBEHÖR • ACCESSORIES



AUSWERFERSTIFTE • EJECTOR PINS

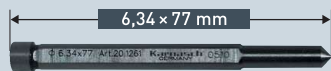

• 20 1261

Packnorm 2 Stk. • Packaging unit 2 pcs.

20 1284

BLUE-DRILL LINE 30 PRO

SETS / DISPLAYS Seite / Page 558



Wir bieten eine große Auswahl an Sets / Displays – Inhaltsvorschläge 20 1284 BLUE-DRILL LINE 30 PRO – siehe Seite 558. Anderer Inhalt auf Wunsch möglich, durch individuell bestückbare Sets / Displays.

We offer a large selection of sets / displays – recommended content 20 1284 BLUE-DRILL LINE 30 PRO – see page 558. Other content possible by individually equipped sets / displays.



Schnittdaten
Cutting data

Film
Movie



1488

- 1
- 2
- 3
- 4
- 5
- 6
- 7
- 8
- 9
- 10

Zubehör für Pulverstahl + DURABLU- beschichteten Kernbohrer, Weldonschaft, Nutzlänge 30 mm
 Accessories for powder steel + DURABLU-coated annular cutter, Weldon shank, drill depth 30 mm | "

BLUE-DRILL LINE 30 PRO 20 1284

ADAPTER + PASSENDE AUSWERFERSTIFTE
ADAPTER + SUITABLE EJECTOR PINS

FEIN Quick-In 18 mm
 Weldon + Nitto/Universal 19 mm 3/4"

 6,34 x 102 mm
 Packnorm 2 Stk. · Packaging unit 2 pcs. 20 1263 20 1271

Nitto/Universal 19 mm 3/4"
 Weldon 19 mm 3/4"

 6,34 x 102 mm
 Packnorm 2 Stk. · Packaging unit 2 pcs. 20 1311 20 1271

Weldon 32 mm 1.1 1/4"
 Weldon + Nitto/Universal 19 mm 3/4"

 6,34 x 77 mm
 Packnorm 2 Stk. · Packaging unit 2 pcs. 21 0048 20 1261

Ersatz-Innensechskantschrauben für alle Adapter siehe Seite 550
 Spare allen screws for all adapters see page 550

VERLÄNGERUNGEN + PASSENDE AUSWERFERSTIFTE
EXTENSIONS + SUITABLE EJECTOR PINS

Weldon 19 mm 3/4"
 Weldon + Nitto/Universal 19 mm 3/4"

 35 mm 50 mm
 7,98 x 6,34 x 5,30 x 127 mm
 Packnorm 2 Stk. · Packaging unit 2 pcs. 20 1387 20 1433

Weldon 19 mm 3/4"
 Weldon + Nitto/Universal 19 mm 3/4"

 35 mm 75 mm
 7,98 x 6,34 x 5,30 x 153 mm
 Packnorm 2 Stk. · Packaging unit 2 pcs. 20 1402 20 1396

Weldon 19 mm 3/4"
 Weldon + Nitto/Universal 19 mm 3/4"

 35 mm 100 mm
 7,98 x 6,34 x 5,30 x 178 mm
 Packnorm 2 Stk. · Packaging unit 2 pcs. 20 1417 20 1411

Ersatz-Innensechskantschrauben für alle Verlängerungen siehe Seite 550
 Spare allen screws for all extensions see page 550

ZUBEHÖR · SETS · DISPLAYS · ERSATZTEILE / ACCESSORIES · SETS · DISPLAYS · SPARE PARTS

Aufnahmehalter mit Morsekonus 2 / 3 / 4 / 5 und Reduzierhülsen 541-543
 Tool holders with morse taper 2 / 3 / 4 / 5 and reduction sleeves

Kühlmittel-Druckflaschen 548
 Coolant pressure bottles

Kegelsenker mit Weldonschaft 544/545
 Countersinks with Weldon shank

Magnetstab zur Entfernung der Bohrspäne 549
 Magnetic stick for chip removal

Spiralbohradapter Weldon + Spiralbohrer Ø 2,5-12 mm 648
 Twist drill adaptors Weldon + twist drills Ø 2,5-12 mm

Sets · Displays 553-582
 Sets · Displays

Gewindeadapter Weldon + Gewindebohrer M 3 - M 30 649-650
 Tapping adapter Weldon + taps M 3 - M 30

Ersatzteile 550-552
 Spare parts

Adapter + passende Bohrfutter 548
 Adapters + suitable drill chucks



20 1317

BLUE-DRILL LINE 55 PRO

Pulverstahl + DURABLU-beschichteter Kernbohrer, Weldonschaft, Nutzlänge 55 mm
 Powder steel + DURABLU-coated annular cutter, Weldon shank, drill depth 55 mm | 2"



ANWENDUNG • APPLICATION

Stahl	Edelstahl	Grauguss	Alu	Kupfer, Messing, Zinn	Kunststoffe GFK/CFK	Hastelloy, Inconel, Exotische Materialien	Hardox 400, 450
Steel	Stainless	Grey cast iron	Alu	Copper, brass, tin	Plastics GRP/CRP	Hastelloy, Inconel, exotic materials	Hardox 400, 450
< 1400 N	> 900 N		> 10% Si				

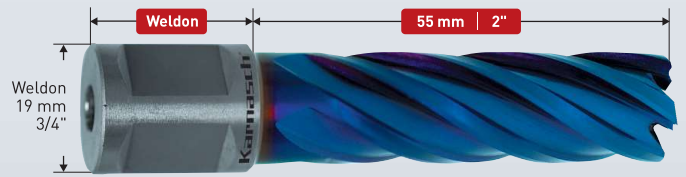

Art.	Ø mm	Ø Zoll Inch
20 1317 012	• 12	15/32"
20 1317 013	• 13	33/64"
20 1317 014	• 14	35/64"
20 1317 015	• 15	19/32"
20 1317 016	• 16	5/8"
20 1317 017	• 17	43/64"
20 1317 018	• 18	45/64"

Art.	Ø mm	Ø Zoll Inch
20 1317 019	• 19	3/4"
20 1317 020	• 20	25/32"
20 1317 021	• 21	53/64"
20 1317 022	• 22	55/64"
20 1317 023	• 23	29/32"
20 1317 024	• 24	15/16"
20 1317 025	• 25	63/64"

Art.	Ø mm	Ø Zoll Inch
20 1317 026	• 26	1.1/32"
20 1317 027	• 27	1.1/16"
20 1317 029	• 29	1.9/64"
20 1317 030	• 30	1.3/16"
20 1317 031	• 31	1.7/32"
20 1317 032	• 32	1.17/64"
20 1317 033	• 33	1.19/64"

Art.	Ø mm	Ø Zoll Inch
20 1317 034	• 34	1.11/32"
20 1317 035	• 35	1.3/8"
20 1317 036	• 36	1.27/64"

% Sonderpreis / Sale Artikel.
 Lieferbar solange Vorrat.
 Special price / sale article.
 While stocks last.

Ersatzartikel siehe Art. 20 1316 Seite 384

Achtung: Die Zollabmessungen entsprechen nicht exakt den mm Durchmesser.

Replacement article see Art. 20 1316 page 384

Attention: The inch sizes do not correspond exactly to the mm diameters.

20 1317

BLUE-DRILL LINE 55 PRO

ZUBEHÖR • ACCESSORIES



AUSWERFERSTIFTE • EJECTOR PINS

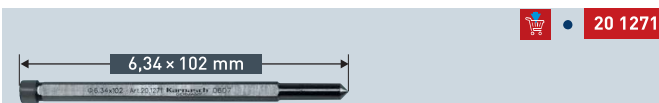

Packnorm 2 Stk. • Packaging unit 2 pcs.

20 1317

BLUE-DRILL LINE 55 PRO

SETS / DISPLAYS Seite / Page 559

Wir bieten eine große Auswahl an Sets / Displays – Inhaltsvorschläge 20 1317 BLUE-DRILL LINE 55 PRO – siehe Seite 559. Anderer Inhalt auf Wunsch möglich, durch individuell bestückbare Sets / Displays.

We offer a large selection of sets / displays – recommended content 20 1317 BLUE-DRILL LINE 55 PRO – see page 559. Other content possible by individually equipped sets / displays.



Schnittdaten
Cutting data

Film
Movie



1488

Zubehör für Pulverstahl + DURABLU- beschichteten Kernbohrer, Weldonschaft, Nutzlänge 55 mm
 Accessories for powder steel + DURABLU-coated annular cutter, Weldon shank, drill depth 55 mm | 2"

BLUE-DRILL LINE **55**
PRO

20 1317

ADAPTER + PASSENDE AUSWERFERSTIFTE
ADAPTER + SUITABLE EJECTOR PINS

FEIN Quick-In 18 mm
 Weldon + Nitto/Universal 19 mm 3/4"



6,34 x 130 mm

Packnorm 2 Stk. · Packaging unit 2 pcs.

20 1263

20 1160

Nitto/Universal 19 mm 3/4"
 Weldon 19 mm 3/4"

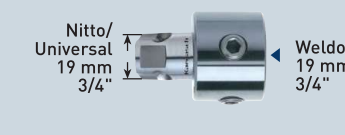

6,34 x 130 mm

Packnorm 2 Stk. · Packaging unit 2 pcs.

20 1311

20 1160

Weldon 32 mm 1.1/4"
 Weldon + Nitto/Universal 19 mm 3/4"



6,34 x 102 mm

Packnorm 2 Stk. · Packaging unit 2 pcs.

21 0048

20 1271

Ersatz-Innensechskantschrauben für alle Adapter siehe Seite 550
 Spare allen screws for all adapters see page 550

VERLÄNGERUNGEN + PASSENDE AUSWERFERSTIFTE
EXTENSIONS + SUITABLE EJECTOR PINS

Weldon 19 mm 3/4"
 Weldon + Nitto/Universal 19 mm 3/4"

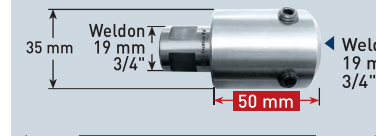

35 mm

50 mm

7,98 x 6,34 x 5,30 x 153 mm

Packnorm 2 Stk. · Packaging unit 2 pcs.

20 1387

20 1396

Weldon 19 mm 3/4"
 Weldon + Nitto/Universal 19 mm 3/4"

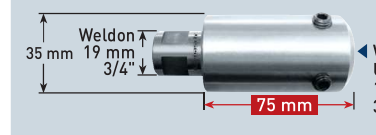

35 mm

75 mm

7,98 x 6,34 x 5,30 x 178 mm

Packnorm 2 Stk. · Packaging unit 2 pcs.

20 1402

20 1411

Weldon 19 mm 3/4"
 Weldon + Nitto/Universal 19 mm 3/4"

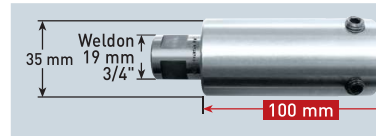

35 mm

100 mm

7,98 x 6,34 x 5,30 x 203 mm

Packnorm 2 Stk. · Packaging unit 2 pcs.

20 1417

20 1426

Ersatz-Innensechskantschrauben für alle Verlängerungen siehe Seite 550
 Spare allen screws for all extensions see page 550

ZUBEHÖR • SETS • DISPLAYS • ERSATZTEILE / ACCESSORIES • SETS • DISPLAYS • SPARE PARTS

Aufnahmehalter mit Morsekonus 2 / 3 / 4 / 5 und Reduzierhülsen 541-543
 Tool holders with morse taper 2 / 3 / 4 / 5 and reduction sleeves



Kühlmittel-Druckflaschen 548
 Coolant pressure bottles



Kegelsenker mit Weldonschaft 544/545
 Countersinks with Weldon shank



Magnetstab zur Entfernung der Bohrspäne 549
 Magnetic stick for chip removal



Spiralbohradapter Weldon + Spiralbohrer Ø 2,5-12 mm 648
 Twist drill adaptors Weldon + twist drills Ø 2,5-12 mm

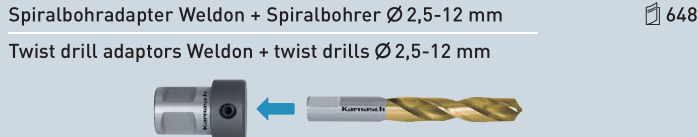

Sets • Displays 553-582
 Sets • Displays



Gewindeadapter Weldon + Gewindebohrer M 3 - M 30 649-650
 Tapping adapter Weldon + taps M 3 - M 30

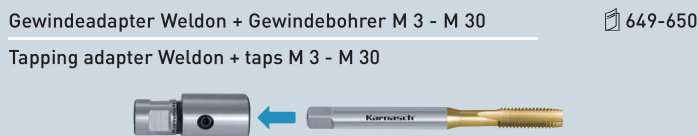

Adapter + passende Bohrfutter 548
 Adapters + suitable drill chucks

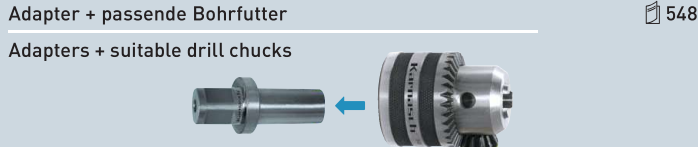

Ersatzteile 550-552
 Spare parts

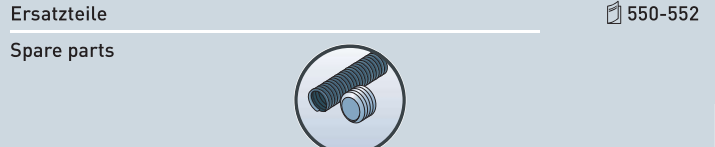

- 1 
- 2 
- 3 
- 4 
- 5 
- 6 
- 7 
- 8 
- 9 
- 10 

HSS-XE + DURABLU-ESCHICHTETE KERNBOHRER HSS-XE + DURABLU-COATED ANNULAR CUTTERS



BLUE-DRILL LINE

Neben Hartmetall-bestückten Kernbohrern bieten beschichtete HSS-XE Kernbohrer das optimale Preis-Leistungs-Verhältnis.

Im harten Einsatz kann nur in den seltensten Fällen auf optimale Drehzahlen und Kühlung Rücksicht genommen werden. Die Karnasch DURABLU-Beschichtung macht den Kernbohrer somit entscheidend widerstandsfähiger. Letztendlich wird dadurch die Lebensdauer des Bohrers wesentlich erhöht.

BLUE-DRILL LINE ist der am häufigsten verwendete Karnasch Kernbohrer. Der HSS-XE Bohrer mit dem besten Preis-Leistungs-Verhältnis für alle Stähle bis 40 Rockwell (HRC) sowie Edelstähle.

Carbide tipped annular cutters and coated HSS-XE cutters provide the optimal price-performance ratio.

The Karnasch DURABLU-coating makes the annular cutter decisively more resistant. This results in a considerable increase of product life.

BLUE-DRILL LINE annular cutters are the most commonly used Karnasch cutters. These HSS-XE cutters offers the best price-performance ratio for all steels up to a strength of 40 Rockwell (HRC) and stainless steels.

EIGENSCHAFTEN · PROPERTIES



Gefertigt aus hochlegiertem HSS-XE Spezialstahl. Für extreme Härte an den Zahnsitzen (bis 68 HRC). Somit hohe Verschleißfestigkeit und Standzeit.

Made of high-alloyed HSS-XE special steel. For extreme hardness at the tip of the tooth (up to 68 HRC). A high wear resistance and lifetime.

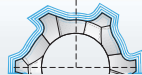

Unsere hochwertigsten Kernbohrer erhalten die einzigartige und patentierte DURABLU-Beschichtung. Extreme Oberflächenhärte- und -glätte ergeben extreme Standzeiten auch unter nicht optimalen Arbeitsbedingungen wie „Über Kopf arbeiten“, Trockenbohrungen, u.s.w.

Our first-class annular cutters are equipped with the unique and patented DURABLU-coating. Extreme surface hardness and sleekness yield extreme lifetimes even under non-optimum conditions like "overhead work", dry drilling, etc.



Nur wenige Hersteller sind in der Lage in Stufen gehärtete Kernbohrer zu fertigen. Für uns ist dies „Standard“. Dadurch erreichen wir extrem harte Zahnsitzen (68 HRC) und dennoch einen flexiblen Kernbohrer.

Only few manufacturers are capable of producing step-hardened annular cutters. For Karnasch this is "standard". Only this makes us produce extremely hard tooth tips (68 HRC) and yet a flexible annular cutter.

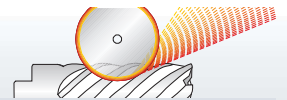

Aus dem vollen Material komplett geschliffen. Dieser Feinschliff erhöht die Zerspanleistung bei gleichzeitiger Reduzierung der Reibung. Für ein Mehr an Standzeit.

Completely made "FULLY GROUND". This refining increases the cutting ability while reducing friction at the same time. For an extended lifetime.

ANWENDUNG · APPLICATION

Stahl	Stahl	Stahl	Edelstahl	Edelstahl	Alu	Alu	Kupfer, Messing, Zinn	Kunststoffe GFK/CFK	Grauguss	Hastelloy, Inconel, Nimonic, Exotische Materialien	Hardox 400	Hardox 450
Steel	Steel	Steel	Stainless	Stainless	Alu	Alu	Copper, brass, tin	Plastics GRP/CRP	Grey cast iron	Hastelloy, Inconel, Nimonic, exotic materials	Hardox 400	Hardox 450
< 900 N	< 1100 N	< 1400 N	< 900 N	> 900 N	< 10% Si	> 10% Si						
✓	✓	✓	✓	✓	✓	✓	✓	✓	✓	✓	✓	✓

✓ OPTIMAL · OPTIMAL



✓ GUT · GOOD

✓ MÖGLICH · POSSIBLE

HSS-XE + DURABLU-ESCHICHTETE KERNBOHRER HSS-XE + DURABLU-COATED ANNULAR CUTTERS

BLUE-DRILL LINE

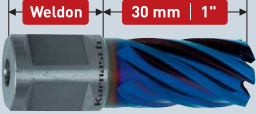
Schnitttiefe · Drill depths

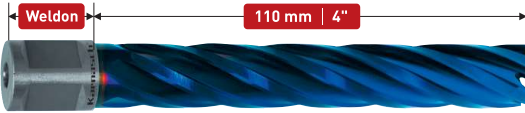
	Ø mm	Ø Zoll/Inch	Art. / Type	
 <p>Weldon 30 mm 1"</p> <p>BEST SELLER</p>	12-60	15/32-2.23/64"	20 1312 BLUE-DRILL LINE/30	412
 <p>Weldon 55 mm 2"</p> <p>BEST SELLER</p>	12-60	15/32-2.23/64"	20 1313 BLUE-DRILL LINE/55	414
 <p>Weldon 80 mm 3"</p>	18-50	45/64-1.31/32"	20 1285 BLUE-DRILL LINE/80	416
 <p>Weldon 110 mm 4"</p>	18-50	45/64-1.31/32"	20 1280 BLUE-DRILL LINE/110	418

ZUBEHÖR · SETS · DISPLAYS · ERSATZTEILE / ACCESSORIES · SETS · DISPLAYS · SPARE PARTS

Aufnahmehalter mit Morsekonus 2 / 3 / 4 / 5 und Reduzierhülsen 541-543
Tool holders with morse taper 2 / 3 / 4 / 5 and reduction sleeves



Kühlmittel-Druckflaschen 548
Coolant pressure bottles



Kegelsenker mit Weldonschaft 544/545
Countersinks with Weldon shank

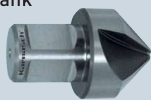

Magnetstab zur Entfernung der Bohrspäne 549
Magnetic stick for chip removal



Spiralbohradapter Weldon + Spiralbohrer Ø 2,5-12 mm 648
Twist drill adaptors Weldon + twist drills Ø 2,5-12 mm



Sets · Displays 553-582
Sets · Displays



Gewintheadapter Weldon + Gewindebohrer M 3 - M 30 649-650
Tapping adapter Weldon + taps M 3 - M 30



Vollhartmetall Gewindebohrer-Ausbohrer 652
Solid carbide drills to remove jammed taps



Adapter + passende Bohrfutter 548
Adapters + suitable drill chucks

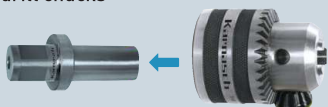

Ersatzteile 550-552
Spare parts



- 1
- 2
- 3
- 4
- 5
- 6
- 7
- 8
- 9
- 10

20 1312

BLUE-DRILL LINE/30

HSS-XE + DURABLUe-beschichteter Kernbohrer, Weldonschaft, Nutzlänge 30 mm
HSS-XE + DURABLUe-coated annular cutter, Weldon shank, drill depth 30 mm | 1"



ANWENDUNG • APPLICATION

Stahl	Edelstahl	Grauguss	Alu	Kupfer, Messing, Zinn	Kunststoffe GFK/CFK	Hardox 400, 450
Steel	Stainless	Grey cast iron	Alu	Copper, brass, tin	Plastics GRP/CRP	Hardox 400, 450
< 1100 N	< 900 N		> 10% Si			

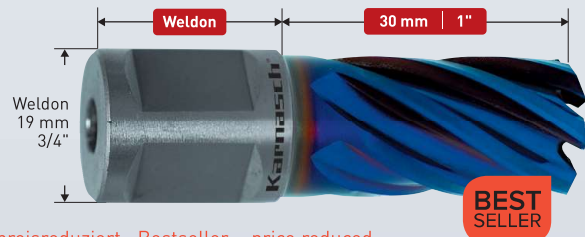

Bestseller – preisreduziert • Bestseller – price reduced

Art.	Ø mm	Ø Zoll Inch	Art.	Ø mm	Ø Zoll Inch	Art.	Ø mm	Ø Zoll Inch	Art.	Ø mm	Ø Zoll Inch
20 1312 012	• 12	15/32"	20 1312 026	• 26	1.1/32"	20 1312 040	• 40	1.37/64"	20 1312 054	• 54	2.1/8"
20 1312 013	• 13	33/64"	20 1312 027	• 27	1.1/16"	20 1312 041	• 41	1.39/64"	20 1312 055	• 55	2.11/64"
20 1312 014	• 14	35/64"	20 1312 028	• 28	1.7/64"	20 1312 042	• 42	1.21/32"	20 1312 056	• 56	2.13/64"
20 1312 015	• 15	19/32"	20 1312 029	• 29	1.9/64"	20 1312 043	• 43	1.11/16"	20 1312 057	• 57	2.1/4"
20 1312 016	• 16	5/8"	20 1312 030	• 30	1.3/16"	20 1312 044	• 44	1.47/64"	20 1312 058	• 58	2.9/32"
20 1312 017	• 17	43/64"	20 1312 031	• 31	1.7/32"	20 1312 045	• 45	1.49/64"	20 1312 059	• 59	2.21/64"
20 1312 018	• 18	45/64"	20 1312 032	• 32	1.17/64"	20 1312 046	• 46	1.13/16"	20 1312 060	• 60	2.23/64"
20 1312 019	• 19	3/4"	20 1312 033	• 33	1.19/64"	20 1312 047	• 47	1.27/32"	20 1312 063	• 63	2.31/64"
20 1312 020	• 20	25/32"	20 1312 034	• 34	1.11/32"	20 1312 048	• 48	1.57/64"			
20 1312 021	• 21	53/64"	20 1312 035	• 35	1.3/8"	20 1312 049	• 49	1.59/64"			
20 1312 022	• 22	55/64"	20 1312 036	• 36	1.27/64"	20 1312 050	• 50	1.31/32"			
20 1312 023	• 23	29/32"	20 1312 037	• 37	1.29/64"	20 1312 051	• 51	2.1/64"			
20 1312 024	• 24	15/16"	20 1312 038	• 38	1.1/2"	20 1312 052	• 52	2.3/64"			
20 1312 025	• 25	63/64"	20 1312 039	• 39	1.17/32"	20 1312 053	• 53	2.3/32"			

% Sonderpreis / Sale Artikel.
Lieferbar solange Vorrat.
Special price / sale article.
While stocks last.

* Mit Weldon 32 mm Sonderpreis solange Vorrat reicht • With Weldon 32 mm special price as long as it is available

Größere Ø siehe Art. 20 1315 Seite 382 sowie Art. 20 1316 Seite 384

Achtung: Die Zollabmessungen entsprechen nicht exakt den mm Durchmessern.

Larger Ø see Art. 20 1315 page 382 and Art. 20 1316 page 384

Attention: The inch sizes do not correspond exactly to the mm diameters.

20 1312

BLUE-DRILL LINE/30

ZUBEHÖR • ACCESSORIES



AUSWERFERSTIFTE • EJECTOR PINS

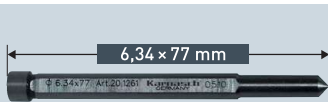

• 20 1261

Packnorm 2 Stk. • Packaging unit 2 pcs.

20 1312

BLUE-DRILL LINE/30

SETS / DISPLAYS Seite / Page 560

Wir bieten eine große Auswahl an Sets / Displays – Inhaltsvorschläge 20 1312 BLUE-DRILL LINE30 – siehe Seite 560. Anderer Inhalt auf Wunsch möglich, durch individuell bestückbare Sets / Displays.

We offer a large selection of sets / displays – recommended content 20 1312 BLUE-DRILL LINE30 – see page 560. Other content possible by individually equipped sets / displays.



Schnittdaten
Cutting data

Film
Movie



1488

Zubehör für HSS-XE + DURABLU- beschichteten Kernbohrer, Weldonschaft, Nutzlänge 30 mm
 Accessories for HSS-XE + DURABLU-coated annular cutter, Weldon shank, drill depth 30 mm | 1"

BLUE-DRILL LINE 30 **20 1312**

ADAPTER + PASSENDE AUSWERFERSTIFTE
ADAPTER + SUITABLE EJECTOR PINS

FEIN Quick-In 18 mm
 Weldon + Nitto/Universal 19 mm 3/4"

 6,34 x 102 mm
 Packnorm 2 Stk. · Packaging unit 2 pcs. **20 1263**

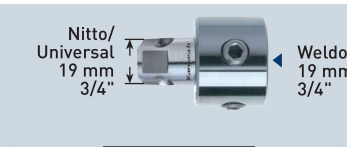
Nitto/Universal 19 mm 3/4"
 Weldon 19 mm 3/4"

 6,34 x 102 mm
 Packnorm 2 Stk. · Packaging unit 2 pcs. **20 1311**

Weldon 32 mm 1.1/4"
 Weldon + Nitto/Universal 19 mm 3/4"

 6,34 x 77 mm
 Packnorm 2 Stk. · Packaging unit 2 pcs. **21 0048**

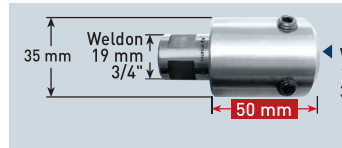
Ersatz-Innensechskantschrauben für alle Adapter siehe Seite 550
 Spare allen screws for all adapters see page 550

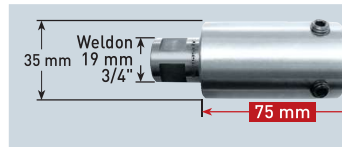
VERLÄNGERUNGEN + PASSENDE AUSWERFERSTIFTE
EXTENSIONS + SUITABLE EJECTOR PINS

Weldon 19 mm 3/4"
 Weldon + Nitto/Universal 19 mm 3/4"

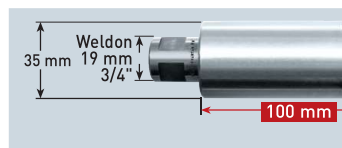
 35 mm
 50 mm
 7,98 x 6,34 x 5,30 x 127 mm
 Packnorm 2 Stk. · Packaging unit 2 pcs. **20 1387**

Weldon 19 mm 3/4"
 Weldon + Nitto/Universal 19 mm 3/4"

 35 mm
 75 mm
 7,98 x 6,34 x 5,30 x 153 mm
 Packnorm 2 Stk. · Packaging unit 2 pcs. **20 1402**

Weldon 19 mm 3/4"
 Weldon + Nitto/Universal 19 mm 3/4"

 35 mm
 100 mm
 7,98 x 6,34 x 5,30 x 178 mm
 Packnorm 2 Stk. · Packaging unit 2 pcs. **20 1417**

Ersatz-Innensechskantschrauben für alle Verlängerungen siehe Seite 550
 Spare allen screws for all extensions see page 550

ZUBEHÖR · SETS · DISPLAYS · ERSATZTEILE / ACCESSORIES · SETS · DISPLAYS · SPARE PARTS

Aufnahmehalter mit Morsekonus 2 / 3 / 4 / 5 und Reduzierhülsen **541-543**
 Tool holders with morse taper 2 / 3 / 4 / 5 and reduction sleeves



Kühlmittel-Druckflaschen **548**
 Coolant pressure bottles

Kegelsenker mit Weldonschaft **544/545**
 Countersinks with Weldon shank

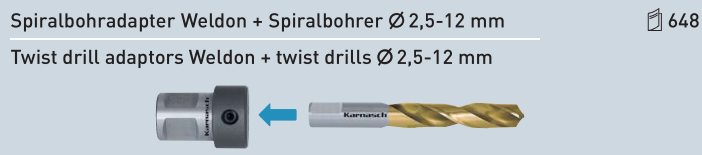

Magnetstab zur Entfernung der Bohrspäne **549**
 Magnetic stick for chip removal

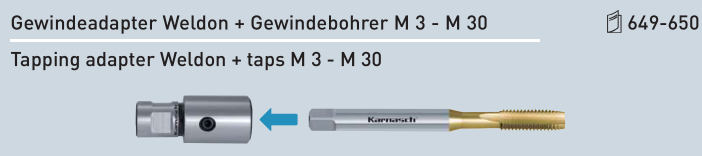
Spiralbohradapter Weldon + Spiralbohrer Ø 2,5-12 mm **648**
 Twist drill adaptors Weldon + twist drills Ø 2,5-12 mm

Sets · Displays **553-582**
 Sets · Displays

Gewindeadapter Weldon + Gewindebohrer M 3 - M 30 **649-650**
 Tapping adapter Weldon + taps M 3 - M 30

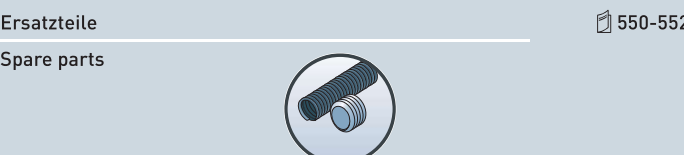
Adapter + passende Bohrfutter **548**
 Adapters + suitable drill chucks

Ersatzteile **550-552**
 Spare parts



20 1313

BLUE-DRILL LINE/55

HSS-XE + DURABLUÉ-beschichteter Kernbohrer, Weldonschaft, Nutzlänge 55 mm
HSS-XE + DURABLUÉ-coated annular cutter, Weldon shank, drill depth 55 mm | 2"



ANWENDUNG • APPLICATION

Stahl	Edelstahl	Grauguss	Alu	Kupfer, Messing, Zinn	Kunststoffe GFK/CFK	Hardox 400, 450
Steel	Stainless	Grey cast iron	Alu	Copper, brass, tin	Plastics GRP/CRP	Hardox 400, 450
< 1100 N	< 900 N		> 10% Si			

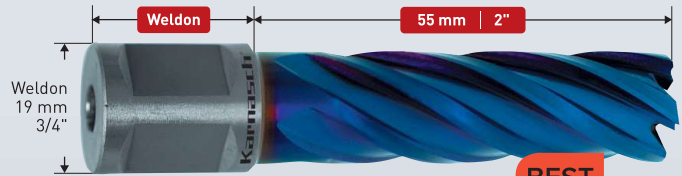

BEST SELLER

Bestseller – preisreduziert • Bestseller – price reduced

Art.	Ø mm	Ø Zoll Inch
20 1313 012	• 12	15/32"
20 1313 013	• 13	33/64"
20 1313 014	• 14	35/64"
20 1313 015	• 15	19/32"
20 1313 016	• 16	5/8"
20 1313 017	• 17	43/64"
20 1313 018	• 18	45/64"
20 1313 019	• 19	3/4"
20 1313 020	• 20	25/32"
20 1313 021	• 21	53/64"
20 1313 022	• 22	55/64"
20 1313 023	• 23	29/32"
20 1313 024	• 24	15/16"
20 1313 025	• 25	63/64"

Art.	Ø mm	Ø Zoll Inch
20 1313 026	• 26	1.1/32"
20 1313 027	• 27	1.1/16"
20 1313 028	• 28	1.7/64"
20 1313 029	• 29	1.9/64"
20 1313 030	• 30	1.3/16"
20 1313 031	• 31	1.7/32"
20 1313 032	• 32	1.17/64"
20 1313 033	• 33	1.19/64"
20 1313 034	• 34	1.11/32"
20 1313 035	• 35	1.3/8"
20 1313 036	• 36	1.27/64"
20 1313 037	• 37	1.29/64"
20 1313 038	• 38	1.1/2"
20 1313 039	• 39	1.17/32"

Art.	Ø mm	Ø Zoll Inch
20 1313 040	• 40	1.37/64"
20 1313 041	• 41	1.39/64"
20 1313 042	• 42	1.21/32"
20 1313 043	• 43	1.11/16"
20 1313 044	• 44	1.47/64"
20 1313 045	• 45	1.49/64"
20 1313 046	• 46	1.13/16"
20 1313 047	• 47	1.27/32"
20 1313 048	• 48	1.57/64"
20 1313 049	• 49	1.59/64"
20 1313 050	• 50	1.31/32"
20 1313 051	• 51	2.1/64"
20 1313 052	• 52	2.3/64"
20 1313 053	• 53	2.3/32"

Art.	Ø mm	Ø Zoll Inch
20 1313 054	• 54	2.1/8"
20 1313 055	• 55	2.11/64"
20 1313 056	• 56	2.13/64"
20 1313 057	• 57	2.1/4"
20 1313 058	• 58	2.9/32"
20 1313 059	• 59	2.21/64"
20 1313 060	• 60	2.23/64"

% Sonderpreis / Sale Artikel.
Lieferbar solange Vorrat.
Special price / sale article.
White stocks last.

Größere Ø siehe Art. 20 1316 Seite 384 -

Achtung: Die Zollabmessungen entsprechen nicht exakt den mm Durchmessern.

Larger Ø see Art. 20 1316 page 384 -

Attention: The inch sizes do not correspond exactly to the mm diameters.

20 1313

BLUE-DRILL LINE/55

ZUBEHÖR • ACCESSORIES



AUSWERFERSTIFTE • EJECTOR PINS

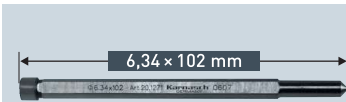

20 1271

Packnorm 2 Stk. • Packaging unit 2 pcs.

20 1313

BLUE-DRILL LINE/55

SETS / DISPLAYS Seite / Page 561



Wir bieten eine große Auswahl an Sets / Displays – Inhaltsvorschläge 20 1313 BLUE-DRILL LINE55 – siehe Seite 561. Anderer Inhalt auf Wunsch möglich, durch individuell bestückbare Sets / Displays.

We offer a large selection of sets / displays – recommended content 20 1313 BLUE-DRILL LINE55 – see page 561. Other content possible by individually equipped sets / displays.



Schnittdaten
Cutting data

Film
Movie



1488

- 1
- 2
- 3
- 4
- 5
- 6
- 7
- 8
- 9
- 10

Zubehör für HSS-XE + DURABLU- beschichteten Kernbohrer, Weldonschaft, Nutzlänge 55 mm
 Accessories for HSS-XE + DURABLU-coated annular cutter, Weldon shank, drill depth 55 mm | 2"

BLUE-DRILL LINE 55

20 1313

**ADAPTER + PASSENDE AUSWERFERSTIFTE
 ADAPTER + SUITABLE EJECTOR PINS**

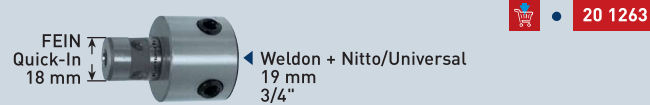

Ersatz-Innensechskantschrauben für alle Adapter siehe Seite 550
 Spare allen screws for all adapters see page 550

**VERLÄNGERUNGEN + PASSENDE AUSWERFERSTIFTE
 EXTENSIONS + SUITABLE EJECTOR PINS**

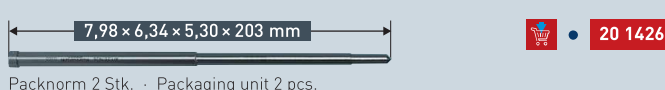
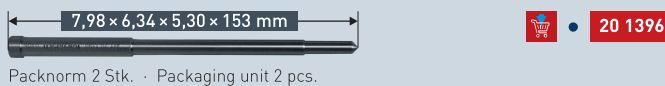

Ersatz-Innensechskantschrauben für alle Verlängerungen siehe Seite 550
 Spare allen screws for all extensions see page 550

ZUBEHÖR • SETS • DISPLAYS • ERSATZTEILE / ACCESSORIES • SETS • DISPLAYS • SPARE PARTS

Aufnahmehalter mit Morsekonus 2 / 3 / 4 / 5 und Reduzierhülsen 541-543
 Tool holders with morse taper 2 / 3 / 4 / 5 and reduction sleeves



Kühlmittel-Druckflaschen 548
 Coolant pressure bottles



Kegelsenker mit Weldonschaft 544/545
 Countersinks with Weldon shank

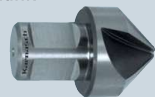

Magnetstab zur Entfernung der Bohrspäne 549
 Magnetic stick for chip removal



Spiralbohradapter Weldon + Spiralbohrer Ø 2,5-12 mm 648
 Twist drill adaptors Weldon + twist drills Ø 2,5-12 mm



Sets • Displays 553-582
 Sets • Displays



Gewindeadapter Weldon + Gewindebohrer M 3 - M 30 649-650
 Tapping adapter Weldon + taps M 3 - M 30



Adapter + passende Bohrfutter 548
 Adapters + suitable drill chucks

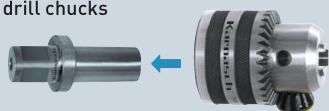

Ersatzteile 550-552
 Spare parts



20 1285

BLUE-DRILL LINE / 80

HSS-XE + DURABLUÉ-beschichteter Kernbohrer, Weldonschaft, Nutzlänge 80 mm
HSS-XE + DURABLUÉ-coated annular cutter, Weldon shank, drill depth 80 mm | 3"



ANWENDUNG • APPLICATION

Stahl	Edelstahl	Grauguss	Alu	Kupfer, Messing, Zinn	Kunststoffe GFK/CFK	Hardox 400, 450
Steel	Stainless	Grey cast iron	Alu	Copper, brass, tin	Plastics GRP/CRP	Hardox 400, 450
< 1100 N	< 900 N		> 10% Si			



Art.	Ø mm	Ø Zoll Inch	Art.	Ø mm	Ø Zoll Inch	Art.	Ø mm	Ø Zoll Inch	Art.	Ø mm	Ø Zoll Inch
20 1285 018	• 18	45/64"	20 1285 024	• 24	15/16"	20 1285 030	• 30	1.3/16"	20 1285 040	• 40	1.37/64"
20 1285 019	• 19	3/4"	20 1285 025	• 25	63/64"	20 1285 032	• 32	1.17/64"	20 1285 045	• 45	1.49/64"
20 1285 020	• 20	25/32"	20 1285 026	• 26	1.1/32"	20 1285 033	• 33	1.19/64"	20 1285 050	• 50	1.31/32"
20 1285 021	• 21	53/64"	20 1285 027	• 27	1.1/16"	20 1285 035	• 35	1.3/8"			
20 1285 022	• 22	55/64"	20 1285 028	• 28	1.7/64"	20 1285 036	• 36	1.27/64"			
20 1285 023	• 23	29/32"	20 1285 029	• 29	1.9/64"	20 1285 038	• 38	1.1/2"			

Weitere Ø siehe Art. 20 1650 Seite 386

Achtung: Die Zollabmessungen entsprechen nicht exakt den mm Durchmessern.

Further Ø see Art. 20 1650 page 386

Attention: The inch sizes do not correspond exactly to the mm diameters.

% Sonderpreis / Sale Artikel.
Lieferbar solange Vorrat.
Special price / sale article.
While stocks last.

20 1285

BLUE-DRILL LINE / 80

ZUBEHÖR • ACCESSORIES

AUSWERFERSTIFTE 1-TEILIG • EJECTOR PINS 1-PIECE

• 20 1439



1-teilig / 1 piece

Packnorm 2 Stk. · Packaging unit 2 pcs.

Zusammen mit Aufnahmehalter 20 1842, 20 1291, 20 1843, 20 1845, 20 1846 (siehe Seite 542–543) kann dieser einteilige Auswerferstift verwendet werden. Es kann ohne Umstecken bis 110 mm Schnitttiefe in einem Arbeitsgang gebohrt werden. Robust und einfach.

It is possible to use this one-piece ejector pin in combination with tool holder article 20 1842, 20 1291, 20 1843, 20 1845, 20 1846 (see page 542–543). You can drill as deep as 110 mm in one working process without changing. Robust and easy.

AUSWERFERSTIFTE 2-TEILIG • EJECTOR PINS 2-PIECE

• 20 1427



2-teilig / 2 piece

Packnorm 2 Stk. · Packaging unit 2 pcs.

ANWENDUNG AUSWERFERSTIFTE 2-TEILIG • APPLICATION EJECTOR PINS 2-PIECE



Anwendung:

Teil 1 in den Schaft des Kernbohrers einführen. Teil 2 auf Teil 1 schieben. Bohren Sie bis ca. 50 mm Schnitttiefe. Danach Teil 2 entfernen und weiter bohren.

Application:

Insert piece 1 into the annular cutter shank. Push piece 2 onto part 1. Drill as deep as 50 mm cutting depth. Then remove piece 2 and continue drilling.

* **Warum 2-teilige Auswerferstifte?** In der Regel haben Standard Morsekonus-Aufnahmehalter eine Schnitttiefenkapazität von 50 mm. Wenn **keine extra langen** Aufnahmehalter verwendet werden (wie auf Seite 542–543 Art. 20 1842, 20 1291, 20 1843, 20 1845, 20 1846), müssen bei Schnitttiefen über 50 mm 2-teilige Auswerferstifte verwendet werden.

* **Why use 2-part ejector pins?** Usually, standard morse taper holders have a cutting depth capacity of 50 mm. If **no extra-long** holders are used (e.g. as on page 542–543 Art. 20 1842, 20 1291, 20 1843, 20 1845, 20 1846), you need for drill depths above 50 mm 2-part ejector pins.

Schnittdaten
Cutting data

Film
Movie



1488



- 1
- 2
- 3
- 4
- 5
- 6
- 7
- 8
- 9
- 10

Index

Zubehör für HSS-XE + DURABLU- beschichteten Kernbohrer, Weldonschaft, Nutzlänge 80 mm
 Accessories for HSS-XE + DURABLU-coated annular cutter, Weldon shank, drill depth 80 mm | 3"

BLUE-DRILL LINE 80

20 1285

ADAPTER + PASSENDE AUSWERFERSTIFTE • ADAPTER + SUITABLE EJECTOR PINS



• **20 1161**



Packnorm 2 Stk. • Packaging unit 2 pcs.



• **20 1314**



Packnorm 2 Stk. • Packaging unit 2 pcs.



• **21 0048**



Packnorm 2 Stk. • Packaging unit 2 pcs.

• **20 1439**



Packnorm 2 Stk. • Packaging unit 2 pcs.

• **20 1427**

Ersatz-Innensechskantschrauben für alle Adapter siehe Seite 550
 Spare allen screws for all adapters see page 550

ZUBEHÖR • SETS • DISPLAYS • ERSATZTEILE / ACCESSORIES • SETS • DISPLAYS • SPARE PARTS

Aufnahmehalter mit Morsekonus 2 / 3 / 4 / 5 und Reduzierhülsen  541-543
 Tool holders with morse taper 2 / 3 / 4 / 5 and reduction sleeves



Kühlmittel-Druckflaschen  548
 Coolant pressure bottles



Kegelsenker mit Weldonschaft  544/545
 Countersinks with Weldon shank

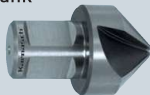



Magnetstab zur Entfernung der Bohrspäne  549
 Magnetic stick for chip removal



Spiralbohradapter Weldon + Spiralbohrer Ø 2,5-12 mm  648
 Twist drill adaptors Weldon + twist drills Ø 2,5-12 mm



Sets • Displays  553-582
 Sets • Displays

Gewindeadapter Weldon + Gewindebohrer M 3 - M 30  649-650
 Tapping adapter Weldon + taps M 3 - M 30



Vollhartmetall Gewindebohrer-Ausbohrer  652
 Solid carbide drills to remove jammed taps



Adapter + passende Bohrfutter  548
 Adapters + suitable drill chucks

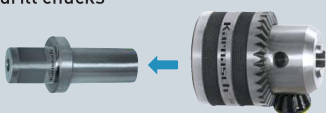

Ersatzteile  550-552
 Spare parts



20 1280

BLUE-DRILL LINE / 110

HSS-XE + DURABLUe-beschichteter Kernbohrer, Weldonschaft, Nutzlänge 110 mm
HSS-XE + DURABLUe-coated annular cutter, Weldon shank, drill depth 110 mm | 4"



ANWENDUNG • APPLICATION

Stahl	Edelstahl	Grauguss	Alu	Kupfer, Messing, Zinn	Kunststoffe GFK/CFK	Hardox 400, 450
Steel	Stainless	Grey cast iron	Alu	Copper, brass, tin	Plastics GRP/CRP	Hardox 400, 450
< 1100 N	< 900 N		> 10% Si			



Art.	Ø mm	Ø Zoll Inch	Art.	Ø mm	Ø Zoll Inch	Art.	Ø mm	Ø Zoll Inch	Art.	Ø mm	Ø Zoll Inch
20 1280 018	• 18	45/64"	20 1280 024	• 24	15/16"	20 1280 030	• 30	1.3/16"	20 1280 040	• 40	1.37/64"
20 1280 019	• 19	3/4"	20 1280 025	• 25	63/64"	20 1280 032	• 32	1.17/64"	20 1280 045	• 45	1.49/64"
20 1280 020	• 20	25/32"	20 1280 026	• 26	1.1/32"	20 1280 033	• 33	1.19/64"	20 1280 050	• 50	1.31/32"
20 1280 021	• 21	53/64"	20 1280 027	• 27	1.1/16"	20 1280 035	• 35	1.3/8"			
20 1280 022	• 22	55/64"	20 1280 028	• 28	1.7/64"	20 1280 036	• 36	1.27/64"			
20 1280 023	• 23	29/32"	20 1280 029	• 29	1.9/64"	20 1280 038	• 38	1.1/2"			

% Sonderpreis / Sale Artikel.
Lieferbar solange Vorrat.
Special price / sale article.
While stocks last.

Weitere Ø siehe Art. 20 1660 Seite 388.
Achtung: Die Zollabmessungen entsprechen nicht exakt den mm Durchmessern.
Further Ø see Art. 20 1660 page 388.
Attention: The inch sizes do not correspond exactly to the mm diameters.

20 1280 BLUE-DRILL LINE / 110 ZUBEHÖR • ACCESSORIES

AUSWERFERSTIFTE 1-TEILIG • EJECTOR PINS 1-PIECE

20 1399



1-teilig / 1 piece

Packnorm 2 Stk. · Packaging unit 2 pcs.

Zusammen mit Aufnahmehalter 20 1842, 20 1291, 20 1843, 20 1845, 20 1846 (siehe Seite 542–543) kann dieser einteilige Auswerferstift verwendet werden. Es kann ohne Umstecken bis 110 mm Schnitttiefe in einem Arbeitsgang gebohrt werden. Robust und einfach.

It is possible to use this one-piece ejector pin in combination with tool holder article 20 1842, 20 1291, 20 1843, 20 1845, 20 1846 (see page 542–543). You can drill as deep as 110 mm in one working process without changing. Robust and easy.

AUSWERFERSTIFTE 2-TEILIG • EJECTOR PINS 2-PIECE

20 1428

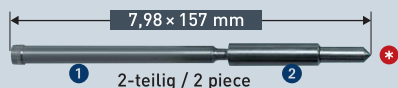

2-teilig / 2 piece

Packnorm 2 Stk. · Packaging unit 2 pcs.

ANWENDUNG AUSWERFERSTIFTE 2-TEILIG • APPLICATION EJECTOR PINS 2-PIECE



Anwendung:

Teil 1 in den Schaft des Kernbohrers einführen. Teil 2 auf Teil 1 schieben. Bohren Sie bis ca. 50 mm Schnitttiefe. Danach Teil 2 entfernen und weiter bohren.

Application:

Insert piece 1 into the annular cutter shank. Push piece 2 onto part 1. Drill as deep as 50 mm cutting depth. Then remove piece 2 and continue drilling.

* **Warum 2-teilige Auswerferstifte?** In der Regel haben Standard Morsekonus-Aufnahmehalter eine Schnitttiefenkapazität von 50 mm. Wenn **keine extra langen** Aufnahmehalter verwendet werden (wie auf Seite 542–543 Art. 20 1842, 20 1291, 20 1843, 20 1845, 20 1846), müssen bei Schnitttiefen über 50 mm 2-teilige Auswerferstifte verwendet werden.

* **Why use 2-part ejector pins?** Usually, standard morse taper holders have a cutting depth capacity of 50 mm. If **no extra-long** holders are used (e.g. as on page 542–543 Art. 20 1842, 20 1291, 20 1843, 20 1845, 20 1846), you need for drill depths above 50 mm 2-part ejector pins.

Schnittdaten
Cutting data

Film
Movie



1488



Zubehör für HSS-XE + DURABLUe-beschichteten Kernbohrer, Weldonschaft, Nutzlänge 110 mm
 Accessories for HSS-XE + DURABLUe-coated annular cutter, Weldon shank, drill depth 110 mm | 4"

BLUE-DRILL LINE 110

20 1280

ADAPTER + PASSENDE AUSWERFERSTIFTE • ADAPTER + SUITABLE EJECTOR PINS



• 20 1161



• 20 1314



• 20 1438



• 20 1438

Packnorm 2 Stk. • Packaging unit 2 pcs.

Packnorm 2 Stk. • Packaging unit 2 pcs.



• 21 0048



• 20 1399

Packnorm 2 Stk. • Packaging unit 2 pcs.



• 20 1428

Packnorm 2 Stk. • Packaging unit 2 pcs.

Ersatz-Innensechskantschrauben für alle Adapter siehe Seite 550
 Spare allen screws for all adapters see page 550

ZUBEHÖR • SETS • DISPLAYS • ERSATZTEILE / ACCESSORIES • SETS • DISPLAYS • SPARE PARTS

Aufnahmehalter mit Morsekonus 2 / 3 / 4 / 5 und Reduzierhülsen 541-543
 Tool holders with morse taper 2 / 3 / 4 / 5 and reduction sleeves



Kühlmittel-Druckflaschen 548
 Coolant pressure bottles



Kegelsenker mit Weldonschaft 544/545
 Countersinks with Weldon shank

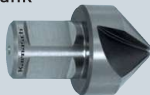

Magnetstab zur Entfernung der Bohrspäne 549
 Magnetic stick for chip removal



Spiralbohradapter Weldon + Spiralbohrer Ø 2,5-12 mm 648
 Twist drill adaptors Weldon + twist drills Ø 2,5-12 mm



Sets • Displays 553-582
 Sets • Displays

Gewindeadapter Weldon + Gewindebohrer M 3 - M 30 649-650
 Tapping adapter Weldon + taps M 3 - M 30



Vollhartmetall Gewindebohrer-Ausbohrer 652
 Solid carbide drills to remove jammed taps



Adapter + passende Bohrfutter 548
 Adapters + suitable drill chucks

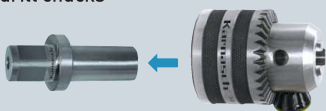

Ersatzteile 550-552
 Spare parts

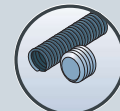

HSS-XE KERNBOHRER HSS-XE ANNULAR CUTTERS



GOLD-DRILL LINE

Karnasch GOLD-DRILL *LINE* Kernbohrer sind die am meisten verwendeten nicht beschichteten HSS-XE Kernbohrer.

Durch speziell GOLD-TECH Oberflächenbehandlung + Vollschliff + HSS-XE Spezialstahl hervorragend zum Bohren in Stähle bis 40 Rockwell (HRC) und sogar geeignet für Edelstähle.

Karnasch GOLD-DRILL *LINE* annular cutters are the most commonly used non-coated HSS-XE annular cutter.

With special surface treatment **GOLD-TECH + FULLY GROUND + special steel HSS-XE** ideal for drilling in steel up to a strength of 40 Rockwell (HRC) and even suitable for stainless steels.

EIGENSCHAFTEN · PROPERTIES



Gefertigt aus hochlegiertem HSS-XE Spezialstahl. Für extreme Härte an den Zahnspitzen (bis 68 HRC). Somit hohe Verschleißfestigkeit und Standzeit.

Made of high-alloyed HSS-XE special steel. For extreme hardness at the tip of the tooth (up to 68 HRC). A high wear resistance and lifetime.

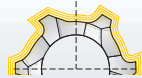

Gold-Tech Oberflächenbehandlung. Die Spezialbehandlung für höhere Standzeiten

Gold-Tech surface treatment. The special treatment for longer lifetimes.



Nur wenige Hersteller sind in der Lage in Stufen gehärtete Kernbohrer zu fertigen. Für uns ist dies „Standard“. Dadurch erreichen wir extrem harte Zahnspitzen (68 HRC) und dennoch einen flexiblen Kernbohrer.

Only few manufacturers are capable of producing step-hardened annular cutters. For Karnasch this is "standard". Only this makes us produce extremely hard tooth tips (68 HRC) and yet a flexible annular cutter.

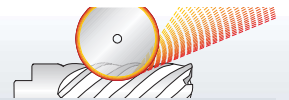

Aus dem vollen Material komplett geschliffen. Dieser Feinschliff erhöht die Zerspanleistung bei gleichzeitiger Reduzierung der Reibung. Für ein Mehr an Standzeit.

Completely made "FULLY GROUND". This refining increases the cutting ability while reducing friction at the same time. For an extended lifetime.

ANWENDUNG · APPLICATION

Stahl	Stahl	Stahl	Edelstahl	Alu	Alu	Kupfer, Messing, Zinn	Kunststoffe GFK/CFK	Hardox 400	Hardox 450
Steel	Steel	Steel	Stainless	Alu	Alu	Copper, brass, tin	Plastics GRP/CRP	Hardox 400	Hardox 450
< 750 N	< 900 N	< 1100 N	< 900 N	< 10% Si	> 10% Si				
✓	✓	✓	✓	✓	✓	✓	✓	✓	✓

✓ OPTIMAL · OPTIMAL

✓ GUT · GOOD









✓ MÖGLICH · POSSIBLE

HSS-XE KERNBOHRER HSS-XE ANNULAR CUTTERS

GOLD-DRILL LINE

Schnitttiefe · Drill depths	Ø mm	Ø Zoll/Inch	Art. / Type	
 BEST SELLER	12-60	15/32-2.23/64"	20 1260U GOLD-DRILL LINE / 30	422
 BEST SELLER	12-60	15/32-2.23/64"	20 1270U GOLD-DRILL LINE / 55	424
	18-50	45/64-1.31/32"	20 1285U GOLD-DRILL LINE / 80	426
	18-50	45/64-1.31/32"	20 1280U GOLD-DRILL LINE / 110	428
	-	7/16-2.1/16"	20 1910 GOLD-DRILL LINE ZOLL/INCH / 30	430
	-	7/16-2.1/16"	20 1920 GOLD-DRILL LINE ZOLL/INCH / 55	432
	-	11/16-2.1/16"	20 1925 GOLD-DRILL LINE ZOLL/INCH / 80	434

ZUBEHÖR · SETS · DISPLAYS · ERSATZTEILE / ACCESSORIES · SETS · DISPLAYS · SPARE PARTS

Aufnahmehalter mit Morsekonus 2 / 3 / 4 / 5 und Reduzierhülsen  541-543	Kühlmittel-Druckflaschen  548
Tool holders with morse taper 2 / 3 / 4 / 5 and reduction sleeves	Coolant pressure bottles
Kegelsenker mit Weldonschaft  544/545	Magnetstab zur Entfernung der Bohrspäne  549
Countersinks with Weldon shank	Magnetic stick for chip removal
Spiralbohradapter Weldon + Spiralbohrer Ø 2,5-12 mm  648	Sets · Displays  553-582
Twist drill adaptors Weldon + twist drills Ø 2,5-12 mm	Sets · Displays
Gewindeadapter Weldon + Gewindebohrer M 3 - M 30  649-650	
Tapping adapter Weldon + taps M 3 - M 30	
Adapter + passende Bohrfutter  548	Ersatzteile  550-552
Adapters + suitable drill chucks	Spare parts

1



2



3



4



5



6



7



8



9



10

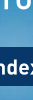

Index

20 1260U

GOLD-DRILL LINE / 30

HSS-XE Kernbohrer, Weldonschaft, Nutzlänge 30 mm
HSS-XE annular cutter, Weldon shank, drill depth 30 mm | 1"



ANWENDUNG • APPLICATION

Stahl	Edelstahl	Grauguss	Alu	Kupfer, Messing, Zinn	Kunststoffe GFK/CFK	Hardox 400, 450
Steel	Stainless	Grey cast iron	Alu	Copper, brass, tin	Plastics GRP/CRP	Hardox 400, 450
< 900 N	< 900 N		< 10% Si			

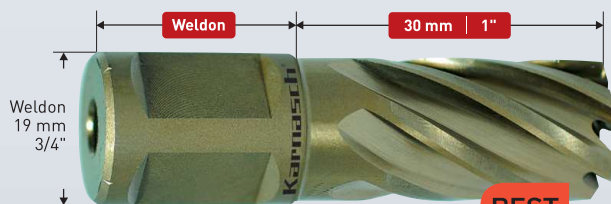

BEST SELLER

Bestseller – preisreduziert • Bestseller – price reduced

Art.	Ø mm	Ø Zoll Inch	Art.	Ø mm	Ø Zoll Inch	Art.	Ø mm	Ø Zoll Inch	Art.	Ø mm	Ø Zoll Inch
20 1260u 012	12	15/32"	20 1260u 022	22	55/64"	20 1260u 035	35	1.3/8"	20 1260u 049	49	1.59/64"
20 1260u 013	13	33/64"	20 1260u 023	23	29/32"	20 1260u 036	36	1.27/64"	20 1260u 050	50	1.31/32"
20 1260u 0135	13,5	17/32"	20 1260u 024	24	15/16"	20 1260u 037	37	1.29/64"	20 1260u 051	51	2.1/64"
20 1260u 014	14	35/64"	20 1260u 025	25	63/64"	20 1260u 038	38	1.1/2"	20 1260u 052	52	2.3/64"
20 1260u 015	15	19/32"	20 1260u 026	26	1.1/32"	20 1260u 039	39	1.17/32"	20 1260u 053	53	2.3/32"
20 1260u 0155	15,5	39/64"	20 1260u 0265	26,5	1.3/64"	20 1260u 040	40	1.37/64"	20 1260u 054	54	2.1/8"
20 1260u 016	16	5/8"	20 1260u 027	27	1.1/16"	20 1260u 041	41	1.39/64"	20 1260u 055	55	2.11/64"
20 1260u 017	17	43/64"	20 1260u 028	28	1.7/64"	20 1260u 042	42	1.21/32"	20 1260u 056	56	2.13/64"
20 1260u 0175	17,5	11/16"	20 1260u 029	29	1.9/64"	20 1260u 043	43	1.11/16"	20 1260u 057	57	2.1/4"
20 1260u 018	18	45/64"	20 1260u 030	30	1.3/16"	20 1260u 044	44	1.47/64"	20 1260u 058	58	2.9/32"
20 1260u 019	19	3/4"	20 1260u 031	31	1.7/32"	20 1260u 045	45	1.49/64"	20 1260u 059	59	2.21/64"
20 1260u 0195	19,5	49/64"	20 1260u 032	32	1.17/64"	20 1260u 046	46	1.13/16"	20 1260u 060	60	2.23/64"
20 1260u 020	20	25/32"	20 1260u 033	33	1.19/64"	20 1260u 047	47	1.27/32"			
20 1260u 021	21	53/64"	20 1260u 034	34	1.11/32"	20 1260u 048	48	1.57/64"			

Größere Ø siehe Art. 20 1315 Seite 382 sowie Art. 20 1316 Seite 384 – Kleinere Ø siehe Art. 20 1230 Seite 442

Achtung: Die Zollabmessungen entsprechen nicht exakt den mm Durchmessern

Larger Ø see Art. 20 1315 page 382 and Art. 20 1316 page 384 – Smaller Ø see Art. 20 1230 page 442

Attention: The inch sizes do not correspond exactly to the mm diameters.

20 1260U

GOLD-DRILL LINE / 30

ZUBEHÖR • ACCESSORIES



AUSWERFERSTIFTE • EJECTOR PINS



20 1261

Packnorm 2 Stk. • Packaging unit 2 pcs.

20 1260U

GOLD-DRILL LINE / 30

SETS / DISPLAYS Seite / Page 562

Wir bieten eine große Auswahl an Sets / Displays – Inhaltsvorschläge 20 1260U GOLD-DRILL LINE30 – siehe Seite 562. Anderer Inhalt auf Wunsch möglich, durch individuell bestückbare Sets / Displays.

We offer a large selection of sets / displays – recommended content 20 1260U GOLD-DRILL LINE30 – see page 562. Other content possible by individually equipped sets / displays.



Schnittdaten
Cutting data

Film
Movie



1488

- 1
- 2
- 3
- 4
- 5
- 6
- 7
- 8
- 9
- 10

Zubehör für HSS-XE Kernbohrer, Weldonschaft, Nutzlänge 30 mm
Accessories for HSS-XE annular cutter, Weldon shank, drill depth 30 mm | 1"

GOLD-DRILL LINE / 30

20 1260U

**ADAPTER + PASSENDE AUSWERFERSTIFTE
ADAPTER + SUITABLE EJECTOR PINS**

FEIN Quick-In 18 mm
Weldon + Nitto/Universal 19 mm 3/4"

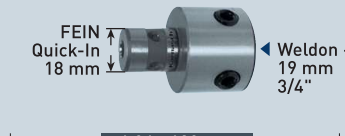

6,34 x 102 mm

Packnorm 2 Stk. · Packaging unit 2 pcs.

20 1263

20 1271

Nitto/Universal 19 mm 3/4" Weldon 19 mm 3/4"

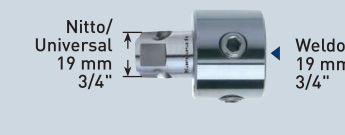

6,34 x 102 mm

Packnorm 2 Stk. · Packaging unit 2 pcs.

20 1311

20 1271

Weldon 32 mm 1.1/4" Weldon + Nitto/Universal 19 mm 3/4"



6,34 x 77 mm

Packnorm 2 Stk. · Packaging unit 2 pcs.

21 0048

20 1261

Ersatz-Innensechskantschrauben für alle Adapter siehe Seite 550
Spare allen screws for all adapters see page 550

**VERLÄNGERUNGEN + PASSENDE AUSWERFERSTIFTE
EXTENSIONS + SUITABLE EJECTOR PINS**

Weldon 19 mm 3/4" Weldon + Nitto/Universal 19 mm 3/4"

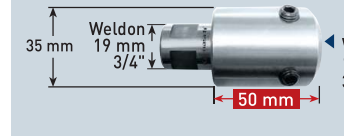

35 mm 50 mm

7,98 x 6,34 x 5,30 x 127 mm

Packnorm 2 Stk. · Packaging unit 2 pcs.

20 1387

20 1433

Weldon 19 mm 3/4" Weldon + Nitto/Universal 19 mm 3/4"

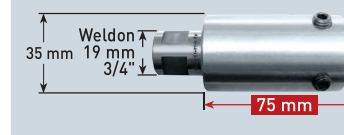

35 mm 75 mm

7,98 x 6,34 x 5,30 x 153 mm

Packnorm 2 Stk. · Packaging unit 2 pcs.

20 1402

20 1396

Weldon 19 mm 3/4" Weldon + Nitto/Universal 19 mm 3/4"

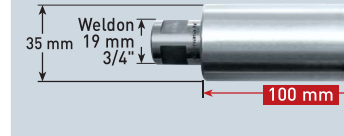

35 mm 100 mm

7,98 x 6,34 x 5,30 x 178 mm

Packnorm 2 Stk. · Packaging unit 2 pcs.

20 1417

20 1411

Ersatz-Innensechskantschrauben für alle Verlängerungen siehe Seite 550
Spare allen screws for all extensions see page 550

ZUBEHÖR · SETS · DISPLAYS · ERSATZTEILE / ACCESSORIES · SETS · DISPLAYS · SPARE PARTS

Aufnahmehalter mit Morsekonus 2 / 3 / 4 / 5 und Reduzierhülsen 541-543
Tool holders with morse taper 2 / 3 / 4 / 5 and reduction sleeves



Kühlmittel-Druckflaschen 548
Coolant pressure bottles



Kegelsenker mit Weldonschaft 544/545
Countersinks with Weldon shank



Magnetstab zur Entfernung der Bohrspäne 549
Magnetic stick for chip removal



Spiralbohradapter Weldon + Spiralbohrer Ø 2,5-12 mm 648
Twist drill adaptors Weldon + twist drills Ø 2,5-12 mm



Sets · Displays 553-582
Sets · Displays



Gewindeadapter Weldon + Gewindebohrer M 3 - M 30 649-650
Tapping adapter Weldon + taps M 3 - M 30



Adapter + passende Bohrfutter 548
Adapters + suitable drill chucks



Ersatzteile 550-552
Spare parts



20 1270U

GOLD-DRILL LINE / 55

HSS-XE Kernbohrer, Weldonschaft, Nutzlänge 55 mm
HSS-XE annular cutter, Weldon shank, drill depth 55 mm | 2"



ANWENDUNG • APPLICATION

Stahl	Edelstahl	Grauguss	Alu	Kupfer, Messing, Zinn	Kunststoffe GFK/CFK	Hardox 400, 450
Steel	Stainless	Grey cast iron	Alu	Copper, brass, tin	Plastics GRP/CRP	Hardox 400, 450
< 900 N	< 900 N		< 10% Si			

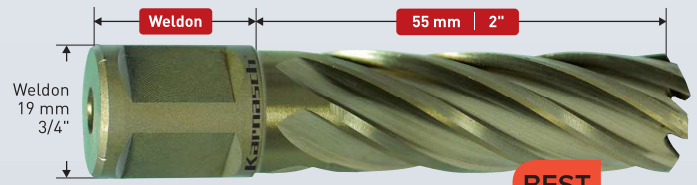

BEST SELLER

Bestseller – preisreduziert • Bestseller – price reduced

☒ Sonderpreis / Sale Artikel. Lieferbar solange Vorrat.
Special price / sale article. While stocks last.

Art.	Ø mm	Ø Zoll Inch	Art.	Ø mm	Ø Zoll Inch	Art.	Ø mm	Ø Zoll Inch	Art.	Ø mm	Ø Zoll Inch
20 1270u 012	• 12	15/32"	20 1270u 022	• 22	55/64"	20 1270u 035	• 35	1.3/8"	20 1270u 049	☒ 49	1.59/64"
20 1270u 013	• 13	33/64"	20 1270u 023	• 23	29/32"	20 1270u 036	• 36	1.27/64"	20 1270u 050	• 50	1.31/32"
20 1270u 0135	• 13,5	17/32"	20 1270u 024	• 24	15/16"	20 1270u 037	• 37	1.29/64"	20 1270u 051	• 51	2.1/64"
20 1270u 014	• 14	35/64"	20 1270u 025	• 25	63/64"	20 1270u 038	• 38	1.1/2"	20 1270u 052	• 52	2.3/64"
20 1270u 015	• 15	19/32"	20 1270u 026	• 26	1.1/32"	20 1270u 039	• 39	1.17/32"	20 1270u 053	• 53	2.3/32"
20 1270u 0155	• 15,5	39/64"	20 1270u 0265	• 26,5	1.3/64"	20 1270u 040	• 40	1.37/64"	20 1270u 054	• 54	2.1/8"
20 1270u 016	• 16	5/8"	20 1270u 027	• 27	1.1/16"	20 1270u 041	• 41	1.39/64"	20 1270u 055	• 55	2.11/64"
20 1270u 017	• 17	43/64"	20 1270u 028	• 28	1.7/64"	20 1270u 042	• 42	1.21/32"	20 1270u 056	• 56	2.13/64"
20 1270u 0175	• 17,5	11/16"	20 1270u 029	• 29	1.9/64"	20 1270u 043	• 43	1.11/16"	20 1270u 057	• 57	2.1/4"
20 1270u 018	• 18	45/64"	20 1270u 030	• 30	1.3/16"	20 1270u 044	• 44	1.47/64"	20 1270u 058	• 58	2.9/32"
20 1270u 019	• 19	3/4"	20 1270u 031	• 31	1.7/32"	20 1270u 045	• 45	1.49/64"	20 1270u 059	• 59	2.21/64"
20 1270u 0195	• 19,5	49/64"	20 1270u 032	• 32	1.17/64"	20 1270u 046	• 46	1.13/16"	20 1270u 060	• 60	2.23/64"
20 1270u 020	• 20	25/32"	20 1270u 033	• 33	1.19/64"	20 1270u 047	• 47	1.27/32"			
20 1270u 021	• 21	53/64"	20 1270u 034	• 34	1.11/32"	20 1270u 048	• 48	1.57/64"			

Größere Ø siehe Art. 20 1316 Seite 384.

Achtung: Die Zollabmessungen entsprechen nicht exakt den mm Durchmessern.

Larger Ø see Art. 20 1316 page 384.

Attention: The inch sizes do not correspond exactly to the mm diameters.

20 1270U

GOLD-DRILL LINE / 55

ZUBEHÖR • ACCESSORIES



AUSWERFERSTIFTE • EJECTOR PINS

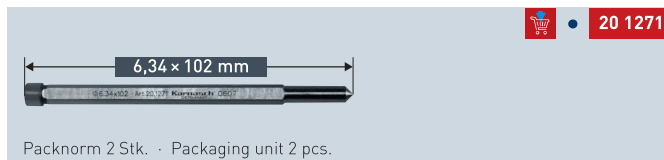

20 1270U

GOLD-DRILL LINE / 55

SETS / DISPLAYS Seite / Page 563



Wir bieten eine große Auswahl an Sets / Displays – Inhaltsvorschläge 20 1270U GOLD-DRILL LINE55 – siehe Seite 563. Anderer Inhalt auf Wunsch möglich, durch individuell bestückbare Sets / Displays.

We offer a large selection of sets / displays – recommended content 20 1270U GOLD-DRILL LINE55 – see page 563. Other content possible by individually equipped sets / displays.



Schnittdaten
Cutting data

Film
Movie



1488

- 1
- 2
- 3
- 4
- 5
- 6
- 7
- 8
- 9
- 10

Zubehör für HSS-XE Kernbohrer, Weldonschaft, Nutzlänge 55 mm
Accessories for HSS-XE annular cutter, Weldon shank, drill depth 55 mm | 2"

GOLD-DRILL LINE / 55

20 1270U

ADAPTER + PASSENDE AUSWERFERSTIFTE
ADAPTER + SUITABLE EJECTOR PINS

FEIN Quick-In 18 mm
Weldon + Nitto/Universal 19 mm 3/4"

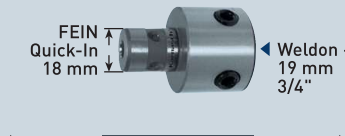

6,34 × 130 mm

Packnorm 2 Stk. · Packaging unit 2 pcs.

20 1263

20 1160

Nitto/Universal 19 mm 3/4" Weldon 19 mm 3/4"

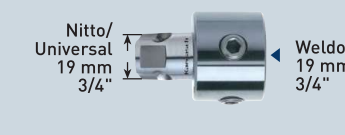

6,34 × 130 mm

Packnorm 2 Stk. · Packaging unit 2 pcs.

20 1311

20 1160

Weldon 32 mm 1.1/4" Weldon + Nitto/Universal 19 mm 3/4"



6,34 × 102 mm

Packnorm 2 Stk. · Packaging unit 2 pcs.

21 0048

20 1271

Ersatz-Innensechskantschrauben für alle Adapter siehe Seite 550
Spare allen screws for all adapters see page 550

VERLÄNGERUNGEN + PASSENDE AUSWERFERSTIFTE
EXTENSIONS + SUITABLE EJECTOR PINS

Weldon 19 mm 3/4" Weldon + Nitto/Universal 19 mm 3/4"

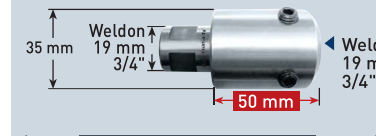

35 mm 50 mm

7,98 × 6,34 × 5,30 × 153 mm

Packnorm 2 Stk. · Packaging unit 2 pcs.

20 1387

20 1396

Weldon 19 mm 3/4" Weldon + Nitto/Universal 19 mm 3/4"

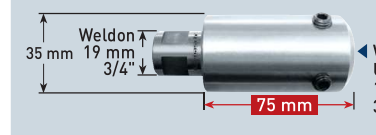

35 mm 75 mm

7,98 × 6,34 × 5,30 × 178 mm

Packnorm 2 Stk. · Packaging unit 2 pcs.

20 1402

20 1411

Weldon 19 mm 3/4" Weldon + Nitto/Universal 19 mm 3/4"

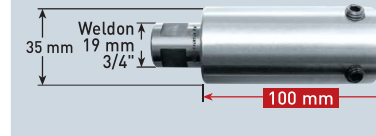

35 mm 100 mm

7,98 × 6,34 × 5,30 × 203 mm

Packnorm 2 Stk. · Packaging unit 2 pcs.

20 1417

20 1426

Ersatz-Innensechskantschrauben für alle Verlängerungen siehe Seite 550
Spare allen screws for all extensions see page 550

ZUBEHÖR · SETS · DISPLAYS · ERSATZTEILE / ACCESSORIES · SETS · DISPLAYS · SPARE PARTS

Aufnahmehalter mit Morsekonus 2 / 3 / 4 / 5 und Reduzierhülsen 541-543
Tool holders with morse taper 2 / 3 / 4 / 5 and reduction sleeves



Kühlmittel-Druckflaschen 548
Coolant pressure bottles



Kegelsenker mit Weldonschaft 544/545
Countersinks with Weldon shank



Magnetstab zur Entfernung der Bohrspäne 549
Magnetic stick for chip removal



Spiralbohradapter Weldon + Spiralbohrer Ø 2,5-12 mm 648
Twist drill adaptors Weldon + twist drills Ø 2,5-12 mm



Sets · Displays 553-582
Sets · Displays



Gewindeadapter Weldon + Gewindebohrer M 3 - M 30 649-650
Tapping adapter Weldon + taps M 3 - M 30



Adapter + passende Bohrfutter 548
Adapters + suitable drill chucks

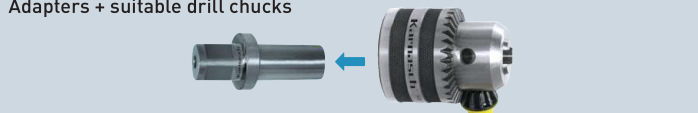

Ersatzteile 550-552
Spare parts



20 1285U

GOLD-DRILL LINE / 80

HSS-XE Kernbohrer, Weldonschaft, Nutzlänge 80 mm

HSS-XE annular cutter, Weldon shank, drill depth 80 mm | 3"



ANWENDUNG • APPLICATION

Stahl	Edelstahl	Grauguss	Alu	Kupfer, Messing, Zinn	Kunststoffe GFK/CFK	Hardox 400, 450
Steel	Stainless	Grey cast iron	Alu	Copper, brass, tin	Plastics GRP/CRP	Hardox 400, 450
< 900 N	< 900 N		< 10% Si			



Art.	Ø mm	Ø Zoll Inch	Art.	Ø mm	Ø Zoll Inch	Art.	Ø mm	Ø Zoll Inch	Art.	Ø mm	Ø Zoll Inch
20 1285u 018	• 18	45/64"	20 1285u 024	• 24	15/16"	20 1285u 030	• 30	1.3/16"	20 1285u 038	• 38	1.1/2"
20 1285u 019	• 19	3/4"	20 1285u 025	• 25	63/64"	20 1285u 032	• 32	1.17/64"	20 1285u 040	• 40	1.37/64"
20 1285u 020	• 20	25/32"	20 1285u 026	• 26	1.1/32"	20 1285u 033	• 33	1.19/64"	20 1285u 045	• 45	1.49/64"
20 1285u 021	• 21	53/64"	20 1285u 027	• 27	1.1/16"	20 1285u 034	• 34	1.11/32"	20 1285u 050	• 50	1.31/32"
20 1285u 022	• 22	55/64"	20 1285u 028	• 28	1.7/64"	20 1285u 035	• 35	1.3/8"			
20 1285u 023	• 23	29/32"	20 1285u 029	• 29	1.9/64"	20 1285u 036	• 36	1.27/64"			

Weitere Ø siehe Art. 20 1650 Seite 386 sowie Art. 20 1660 Seite 388.

Achtung: Die Zollabmessungen entsprechen nicht exakt den mm Durchmessern.

Further Ø see Art. 20 1650 page 386 and Art. 20 1660 page 388.

Attention: The inch sizes do not correspond exactly to the mm diameters.

20 1285U

GOLD-DRILL LINE / 80

ZUBEHÖR • ACCESSORIES



AUSWERFERSTIFTE 1-TEILIG • EJECTOR PINS 1-PIECE

• 20 1439



1-teilig / 1 piece

Packnorm 2 Stk. · Packaging unit 2 pcs.

Zusammen mit Aufnahmehalter 20 1842, 20 1291, 20 1843, 20 1845, 20 1846 (siehe Seite 542–543) kann dieser einteilige Auswerferstift verwendet werden. Es kann ohne Umstecken bis 110 mm Schnitttiefe in einem Arbeitsgang gebohrt werden. Robust und einfach.

It is possible to use this one-piece ejector pin in combination with tool holder article 20 1842, 20 1291, 20 1843, 20 1845, 20 1846 (see page 542–543). You can drill as deep as 110 mm in one working process without changing. Robust and easy.

AUSWERFERSTIFTE 2-TEILIG • EJECTOR PINS 2-PIECE

• 20 1427



2-teilig / 2 piece

Packnorm 2 Stk. · Packaging unit 2 pcs.

ANWENDUNG AUSWERFERSTIFTE 2-TEILIG • APPLICATION EJECTOR PINS 2-PIECE



Anwendung:

Teil 1 in den Schaft des Kernbohrers einführen. Teil 2 auf Teil 1 schieben. Bohren Sie bis ca. 50 mm Schnitttiefe. Danach Teil 2 entfernen und weiter bohren.

Application:

Insert piece 1 into the annular cutter shank. Push piece 2 onto part 1. Drill as deep as 50 mm cutting depth. Then remove piece 2 and continue drilling.

* **Warum 2-teilige Auswerferstifte?** In der Regel haben Standard Morsekonus-Aufnahmehalter eine Schnitttiefenkapazität von 50 mm. Wenn **keine extra langen** Aufnahmehalter verwendet werden (wie auf Seite 542–543 Art. 20 1842, 20 1291, 20 1843, 20 1845, 20 1846), müssen bei Schnitttiefen über 50 mm 2-teilige Auswerferstifte verwendet werden.

* **Why use 2-part ejector pins?** Usually, standard morse taper holders have a cutting depth capacity of 50 mm. If **no extra-long** holders are used (e.g. as on page 542–543 Art. 20 1842, 20 1291, 20 1843, 20 1845, 20 1846), you need for drill depths above 50 mm 2-part ejector pins.

Schnittdaten

Cutting data

Film

Movie



1488



Zubehör für HSS-XE Kernbohrer, Weldonschaft, Nutzlänge 80 mm
 Accessories for HSS-XE annular cutter, Weldon shank, drill depth 80 mm | 3"

GOLD-DRILL LINE / 55

20 1285U

ADAPTER + PASSENDE AUSWERFERSTIFTE • ADAPTER + SUITABLE EJECTOR PINS

FEIN Quick-In 18 mm
 Weldon + Nitto/Universal 19 mm 3/4"



7,98 x 157 mm

1 2-teilig / 2 piece 2 *

Packnorm 2 Stk. · Packaging unit 2 pcs.

20 1161

Nitto/Universal 19 mm 3/4"
 Weldon 19 mm 3/4"

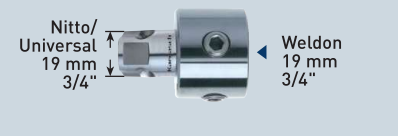

7,98 x 157 mm

1 2-teilig / 2 piece 2 *

Packnorm 2 Stk. · Packaging unit 2 pcs.

20 1314

Weldon 32 mm 1.1/4"
 Weldon + Nitto/Universal 19 mm 3/4"



7,98 x 130 mm

1-teilig / 1 piece

Packnorm 2 Stk. · Packaging unit 2 pcs.

21 0048



7,98 x 130 mm

1 2-teilig / 2 piece 2 *

Packnorm 2 Stk. · Packaging unit 2 pcs.

20 1436

20 1427

Ersatz-Innensechskantschrauben für alle Adapter siehe Seite 550
 Spare allen screws for all adapters see page 550

ZUBEHÖR • SETS • DISPLAYS • ERSATZTEILE / ACCESSORIES • SETS • DISPLAYS • SPARE PARTS

Aufnahmehalter mit Morsekonus 2 / 3 / 4 / 5 und Reduzierhülsen 541-543
 Tool holders with morse taper 2 / 3 / 4 / 5 and reduction sleeves



Kühlmittel-Druckflaschen 548
 Coolant pressure bottles



Kegelsenker mit Weldonschaft 544/545
 Countersinks with Weldon shank



Magnetstab zur Entfernung der Bohrspäne 549
 Magnetic stick for chip removal



Spiralbohradapter Weldon + Spiralbohrer Ø 2,5-12 mm 648
 Twist drill adaptors Weldon + twist drills Ø 2,5-12 mm



Sets · Displays 553-582
 Sets · Displays



Gewindeadapter Weldon + Gewindebohrer M 3 - M 30 649-650
 Tapping adapter Weldon + taps M 3 - M 30



Vollhartmetall Gewindebohrer-Ausbohrer 652
 Solid carbide drills to remove jammed taps



Adapter + passende Bohrfutter 548
 Adapters + suitable drill chucks

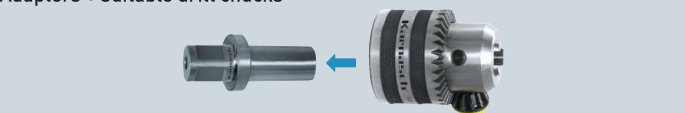

Ersatzteile 550-552
 Spare parts



20 1280U

GOLD-DRILL LINE 110

HSS-XE Kernbohrer, Weldonschaft, Nutzlänge 110 mm
HSS-XE annular cutter, Weldon shank, drill depth 110 mm | 4"



ANWENDUNG • APPLICATION

Stahl	Edelstahl	Grauguss	Alu	Kupfer, Messing, Zinn	Kunststoffe GFK/CFK	Hardox 400, 450
Steel	Stainless	Grey cast iron	Alu	Copper, brass, tin	Plastics GRP/CRP	Hardox 400, 450
< 900 N	< 900 N		< 10% Si			



% Sonderpreis / Sale Artikel. Lieferbar solange Vorrat.
Special price / sale article. While stocks last.

Art.	Ø mm	Ø Zoll Inch	Art.	Ø mm	Ø Zoll Inch	Art.	Ø mm	Ø Zoll Inch	Art.	Ø mm	Ø Zoll Inch
20 1280u 018	• 18	45/64"	20 1280u 024	• 24	15/16"	20 1280u 030	• 30	1.3/16"	20 1280u 040	• 40	1.37/64"
20 1280u 019	• 19	3/4"	20 1280u 025	• 25	63/64"	20 1280u 032	• 32	1.17/64"	20 1280u 045	• 45	1.49/64"
20 1280u 020	• 20	25/32"	20 1280u 026	• 26	1.1/32"	20 1280u 033	• 33	1.19/64"	20 1280u 050	• 50	1.31/32"
20 1280u 021	• 21	53/64"	20 1280u 027	• 27	1.1/16"	20 1280u 035	• 35	1.3/8"			
20 1280u 022	• 22	55/64"	20 1280u 028	• 28	1.7/64"	20 1280u 036	% 36	1.27/64"			
20 1280u 023	• 23	29/32"	20 1280u 029	• 29	1.9/64"	20 1280u 038	• 38	1.1/2"			

Weitere Ø siehe Art. 20 1660 Seite 388

Achtung: Die Zollabmessungen entsprechen nicht exakt den mm Durchmessern.

Further Ø see Art. 20 1660 page 388

Attention: The inch sizes do not correspond exactly to the mm diameters.

20 1280U

GOLD-DRILL LINE 110

ZUBEHÖR • ACCESSORIES



AUSWERFERSTIFTE 1-TEILIG • EJECTOR PINS 1-PIECE

• 20 1399



1-teilig / 1 piece

Packnorm 2 Stk. · Packaging unit 2 pcs.

Zusammen mit Aufnahmehalter 20 1842, 20 1291, 20 1843, 20 1845, 20 1846 (siehe Seite 542–543) kann dieser einteilige Auswerferstift verwendet werden. Es kann ohne Umstecken bis 110 mm Schnitttiefe in einem Arbeitsgang gebohrt werden. Robust und einfach.

It is possible to use this one-piece ejector pin in combination with tool holder article 20 1842, 20 1291, 20 1843, 20 1845, 20 1846 (see page 542–543). You can drill as deep as 110 mm in one working process without changing. Robust and easy.

AUSWERFERSTIFTE 2-TEILIG EJECTOR PINS 2-PIECE

• 20 1428

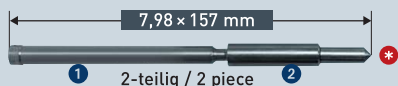

2-teilig / 2 piece

Packnorm 2 Stk. · Packaging unit 2 pcs.

ANWENDUNG AUSWERFERSTIFTE 2-TEILIG APPLICATION EJECTOR PINS 2-PIECE



Anwendung:

Teil 1 in den Schaft des Kernbohrers einführen. Teil 2 auf Teil 1 schieben. Bohren Sie bis ca. 50 mm Schnitttiefe. Danach Teil 2 entfernen und weiter bohren.

Application:

Insert piece 1 into the annular cutter shank. Push piece 2 onto part 1. Drill as deep as 50 mm cutting depth. Then remove piece 2 and continue drilling.

* **Warum 2-teilige Auswerferstifte?** In der Regel haben Standard Morsekonus-Aufnahmehalter eine Schnitttiefenkapazität von 50 mm. Wenn **keine extra langen** Aufnahmehalter verwendet werden (wie auf Seite 542–543 Art. 20 1842, 20 1291, 20 1843, 20 1845, 20 1846), müssen bei Schnitttiefen über 50 mm 2-teilige Auswerferstifte verwendet werden.

* **Why use 2-part ejector pins?** Usually, standard morse taper holders have a cutting depth capacity of 50 mm. If **no extra-long** holders are used (e.g. as on page 542–543 Art. 20 1842, 20 1291, 20 1843, 20 1845, 20 1846), you need for drill depths above 50 mm 2-part ejector pins.

Schnittdaten
Cutting data

Film
Movie



1488



1
2
3
4
5
6
7
8
9
10

Index

Zubehör für HSS-XE Kernbohrer, Weldonschaft, Nutzlänge 110 mm
Accessories for HSS-XE annular cutter, Weldon shank, drill depth 110 mm | 4"

GOLD-DRILL LINE 110

20 1280U

ADAPTER + PASSENDE AUSWERFERSTIFTE • ADAPTER + SUITABLE EJECTOR PINS

FEIN Quick-In 18 mm
Weldon + Nitto/Universal 19 mm 3/4"

• 20 1161



Packnorm 2 Stk. · Packaging unit 2 pcs.

Nitto/Universal 19 mm 3/4"
Weldon 19 mm 3/4"

• 20 1314



Packnorm 2 Stk. · Packaging unit 2 pcs.

Weldon 32 mm 1.1/4"
Weldon + Nitto/Universal 19 mm 3/4"

• 21 0048



Packnorm 2 Stk. · Packaging unit 2 pcs.

• 20 1399



Packnorm 2 Stk. · Packaging unit 2 pcs.

• 20 1428

Ersatz-Innensechskantschrauben für alle Adapter siehe Seite 550
Spare allen screws for all adapters see page 550

ZUBEHÖR • SETS • DISPLAYS • ERSATZTEILE / ACCESSORIES • SETS • DISPLAYS • SPARE PARTS

Aufnahmehalter mit Morsekonus 2 / 3 / 4 / 5 und Reduzierhülsen 541-543
Tool holders with morse taper 2 / 3 / 4 / 5 and reduction sleeves



Kühlmittel-Druckflaschen 548
Coolant pressure bottles



Kegelsenker mit Weldonschaft 544/545
Countersinks with Weldon shank

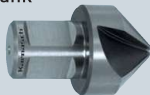

Magnetstab zur Entfernung der Bohrspäne 549
Magnetic stick for chip removal



Spiralbohradapter Weldon + Spiralbohrer Ø 2,5-12 mm 648
Twist drill adaptors Weldon + twist drills Ø 2,5-12 mm



Sets · Displays 553-582
Sets · Displays

Gewindeadapter Weldon + Gewindebohrer M 3 - M 30 649-650
Tapping adapter Weldon + taps M 3 - M 30



Vollhartmetall Gewindebohrer-Ausbohrer 652
Solid carbide drills to remove jammed taps



Adapter + passende Bohrfutter 548
Adapters + suitable drill chucks

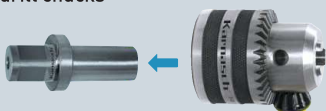

Ersatzteile 550-552
Spare parts



- 1
- 2
- 3
- 4
- 5
- 6
- 7
- 8
- 9
- 10

20 1910

GOLD-DRILL LINE 30
ZOLL / INCH

HSS-XE Kernbohrer, Weldonschaft, Nutzlänge 30 mm
HSS-XE annular cutter, Weldon shank, drill depth 30 mm | 1"



ANWENDUNG • APPLICATION

Stahl	Edelstahl	Grauguss	Alu	Kupfer, Messing, Zinn	Kunststoffe GFK/CFK	Hardox 400, 450
Steel	Stainless	Grey cast iron	Alu	Copper, brass, tin	Plastics GRP/CRP	Hardox 400, 450
< 900 N	< 900 N		< 10% Si			

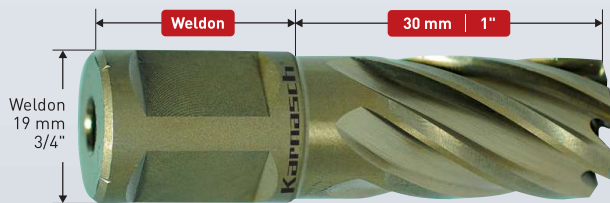

Zoll/Inch	Ø mm	Art.	Zoll/Inch	Ø mm	Art.	Zoll/Inch	Ø mm	Art.	Zoll/Inch	Ø mm	Art.
• 7/16"	11,10	20 1910 005	• 15/16"	23,81	20 1910 045	• 1.7/16"	36,51	20 1910 085	• 1.15/16"	49,21	20 1910 125
• 1/2"	12,70	20 1910 010	• 1"	25,40	20 1910 050	• 1.1/2"	38,10	20 1910 090	• 2"	50,80	20 1910 130
• 9/16"	14,28	20 1910 015	• 1.1/16"	26,98	20 1910 055	• 1.9/16"	39,68	20 1910 095	• 2.1/16"	52,38	20 1910 135
• 5/8"	15,87	20 1910 020	• 1.1/8"	28,57	20 1910 060	• 1.5/8"	41,27	20 1910 100			
• 11/16"	17,46	20 1910 025	• 1.3/16"	30,13	20 1910 065	• 1.11/16"	42,86	20 1910 105			
• 3/4"	19,04	20 1910 030	• 1.1/4"	31,75	20 1910 070	• 1.3/4"	44,45	20 1910 110			
• 13/16"	20,63	20 1910 035	• 1.5/16"	33,33	20 1910 075	• 1.13/16"	46,03	20 1910 115			
• 7/8"	22,22	20 1910 040	• 1.3/8"	34,92	20 1910 080	• 1.7/8"	47,62	20 1910 120			

Achtung: Die Zollabmessungen entsprechen nicht exakt den mm Durchmesser.
Attention: The inch sizes do not correspond exactly to the mm diameters.

20 1910

GOLD-DRILL LINE 30
ZOLL / INCH

ZUBEHÖR • ACCESSORIES



AUSWERFERSTIFTE • EJECTOR PINS



Packnorm 2 Stk. · Packaging unit 2 pcs.

Ø 7/16" • 20 1482



Packnorm 2 Stk. · Packaging unit 2 pcs.

Ø 1/2" - 2.1/16" • 20 1261

20 1910

GOLD-DRILL LINE 30
ZOLL / INCH

SETS / DISPLAYS Seite / Page 564



Wir bieten eine große Auswahl an Sets / Displays – Inhaltsvorschläge 20 1910 GOLD-DRILL LINE30 – siehe Seite 564. Anderer Inhalt auf Wunsch möglich, durch individuell bestückbare Sets / Displays.
We offer a large selection of sets / displays – recommended content 20 1910 GOLD-DRILL LINE30 – see page 564. Other content possible by individually equipped sets / displays.



Schnittdaten
Cutting data

Film
Movie



1488

- 1
- 2
- 3
- 4
- 5
- 6
- 7
- 8
- 9
- 10

Zubehör für HSS-XE Kernbohrer, Weldonschaft, Nutzlänge 30 mm
Accessories for HSS-XE annular cutter, Weldon shank, drill depth 30 mm | 1"

GOLD-DRILL LINE 30 20 1910
ZOLL / INCH

ADAPTER + PASSENDE AUSWERFERSTIFTE
ADAPTER + SUITABLE EJECTOR PINS

FEIN Quick-In 18 mm
Weldon + Nitto/Universal 19 mm 3/4"

6,34 x 102 mm

Packnorm 2 Stk. · Packaging unit 2 pcs. **20 1263**

6,34 x 102 mm **20 1271**

Weldon 32 mm 1.1/4"
Weldon + Nitto/Universal 19 mm 3/4"

4,74 x 77 mm **21 0048**

Packnorm 2 Stk. · Packaging unit 2 pcs. **Ø 7/16" · 20 1482**

6,34 x 77 mm **20 1261**

Packnorm 2 Stk. · Packaging unit 2 pcs. **Ø 1/2" - 2.1/16" · 20 1261**

Nitto/Universal 19 mm 3/4"
Weldon 19 mm 3/4"

6,34 x 102 mm **20 1311**

Packnorm 2 Stk. · Packaging unit 2 pcs. **20 1271**

Ersatz-Innensechskantschrauben für alle Adapter siehe Seite 550
Spare allen screws for all adapters see page 550

VERLÄNGERUNGEN + PASSENDE AUSWERFERSTIFTE
EXTENSIONS + SUITABLE EJECTOR PINS

Nitto/Universal 19 mm 3/4"
Weldon + Nitto/Universal 19 mm 3/4"

50 mm

7,98 x 6,34 x 5,30 x 127 mm **20 1406**

Packnorm 2 Stk. · Packaging unit 2 pcs. **20 1433**

Nitto/Universal 19 mm 3/4"
Weldon + Nitto/Universal 19 mm 3/4"

75 mm

7,98 x 6,34 x 5,30 x 153 mm **20 1407**

Packnorm 2 Stk. · Packaging unit 2 pcs. **20 1396**

Nitto/Universal 19 mm 3/4"
Weldon + Nitto/Universal 19 mm 3/4"

100 mm

7,98 x 6,34 x 5,30 x 178 mm **20 1409**

Packnorm 2 Stk. · Packaging unit 2 pcs. **20 1411**

Ersatz-Innensechskantschrauben für alle Verlängerungen siehe Seite 550
Spare allen screws for all extensions see page 550

ZUBEHÖR • SETS • DISPLAYS • ERSATZTEILE / ACCESSORIES • SETS • DISPLAYS • SPARE PARTS

Aufnahmelhalter mit Morsekonus 2 / 3 / 4 / 5 und Reduzierhülsen **541-543**
Tool holders with morse taper 2 / 3 / 4 / 5 and reduction sleeves

Kühlmittel-Druckflaschen **548**
Coolant pressure bottles

Kegelsenker mit Weldonschaft **544/545**
Countersinks with Weldon shank

Magnetstab zur Entfernung der Bohrspäne **549**
Magnetic stick for chip removal

Spiralbohradapter Weldon + Spiralbohrer Ø 4-12 mm **648**
Twist drill adaptors Weldon + twist drills Ø 4-12 mm

Sets · Displays **553-582**
Sets · Displays

Gewindeadapter Weldon + Gewindebohrer M 6 - M 30 **649-650**
Tapping adapter Weldon + taps M 6 - M 30

Ersatzteile **550-552**
Spare parts

Adapter + passende Bohrfutter **548**
Adapters + suitable drill chucks



20 1920

GOLD-DRILL LINE 55
ZOLL / INCH

HSS-XE Kernbohrer, Weldonschaft, Nutzlänge 55 mm
HSS-XE annular cutter, Weldon shank, drill depth 55 mm | 2"



ANWENDUNG • APPLICATION

Stahl	Edelstahl	Grauguss	Alu	Kupfer, Messing, Zinn	Kunststoffe GFK/CFK	Hardox 400, 450
Steel	Stainless	Grey cast iron	Alu	Copper, brass, tin	Plastics GRP/CRP	Hardox 400, 450
< 900 N	< 900 N		< 10% Si			

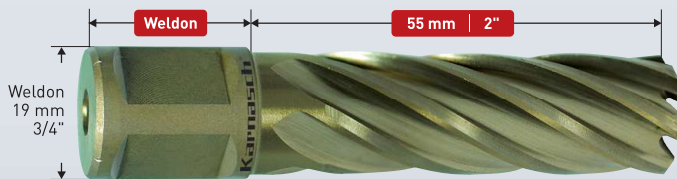

Zoll/Inch	Ø mm	Art.	Zoll/Inch	Ø mm	Art.	Zoll/Inch	Ø mm	Art.	Zoll/Inch	Ø mm	Art.
• 7/16"	11,10	20 1920 005	• 15/16"	23,81	20 1920 045	• 1.7/16"	36,51	20 1920 085	• 1.15/16"	49,21	20 1920 125
• 1/2"	12,70	20 1920 010	• 1"	25,40	20 1920 050	• 1.1/2"	38,10	20 1920 090	• 2"	50,80	20 1920 130
• 9/16"	14,28	20 1920 015	• 1.1/16"	26,98	20 1920 055	• 1.9/16"	39,68	20 1920 095	• 2.1/16"	52,38	20 1920 135
• 5/8"	15,87	20 1920 020	• 1.1/8"	28,57	20 1920 060	• 1.5/8"	41,27	20 1920 100			
• 11/16"	17,46	20 1920 025	• 1.3/16"	30,13	20 1920 065	• 1.11/16"	42,86	20 1920 105			
• 3/4"	19,04	20 1920 030	• 1.1/4"	31,75	20 1920 070	• 1.3/4"	44,45	20 1920 110			
• 13/16"	20,63	20 1920 035	• 1.5/16"	33,33	20 1920 075	• 1.13/16"	46,03	20 1920 115			
• 7/8"	22,22	20 1920 040	• 1.3/8"	34,92	20 1920 080	• 1.7/8"	47,62	20 1920 120			

Achtung: Die Zollabmessungen entsprechen nicht exakt den mm Durchmesser.
Attention: The inch sizes do not correspond exactly to the mm diameters.

20 1920

GOLD-DRILL LINE 55
ZOLL / INCH

ZUBEHÖR • ACCESSORIES



AUSWERFERSTIFTE • EJECTOR PINS



Ø 7/16" • 20 1485

Packnorm 2 Stk. · Packaging unit 2 pcs.



Ø 1/2" - 2.1/16" • 20 1271

Packnorm 2 Stk. · Packaging unit 2 pcs.

20 1920

GOLD-DRILL LINE 55
ZOLL / INCH

SETS / DISPLAYS Seite / Page 565



Wir bieten eine große Auswahl an Sets / Displays – Inhaltsvorschläge 20 1920 GOLD-DRILL LINE55 – siehe Seite 565. Anderer Inhalt auf Wunsch möglich, durch individuell bestückbare Sets / Displays.
We offer a large selection of sets / displays – recommended content 20 1920 GOLD-DRILL LINE55 – see page 565. Other content possible by individually equipped sets / displays.



Schnittdaten
Cutting data

Film
Movie



1488

- 1
- 2
- 3
- 4
- 5
- 6
- 7
- 8
- 9
- 10

Index

Zubehör für HSS-XE Kernbohrer, Weldonschaft, Nutzlänge 55 mm
Accessories for HSS-XE annular cutter, Weldon shank, drill depth 55 mm | 2"

GOLD-DRILL LINE 55 ZOLL / INCH **20 1920**

ADAPTER + PASSENDE AUSWERFERSTIFTE
ADAPTER + SUITABLE EJECTOR PINS

FEIN Quick-In 18 mm
Weldon + Nitto/Universal 19 mm 3/4"

6,34 x 130 mm

Packnorm 2 Stk. · Packaging unit 2 pcs. **20 1263**

Weldon 32 mm 1.1/4"

Weldon + Nitto/Universal 19 mm 3/4"

4,74 x 102 mm

Packnorm 2 Stk. · Packaging unit 2 pcs. **21 0048**

6,34 x 102 mm

Packnorm 2 Stk. · Packaging unit 2 pcs. **Ø 7/16" · 20 1485**

Nitto/Universal 19 mm 3/4"

Weldon 19 mm 3/4"

6,34 x 130 mm

Packnorm 2 Stk. · Packaging unit 2 pcs. **20 1311**

Ersatz-Innensechskantschrauben für alle Adapter siehe Seite 550
Spare allen screws for all adapters see page 550

VERLÄNGERUNGEN + PASSENDE AUSWERFERSTIFTE
EXTENSIONS + SUITABLE EJECTOR PINS

35 mm Nitto/Universal 19 mm 3/4"

Weldon + Nitto/Universal 19 mm 3/4"

50 mm

7,98 x 6,34 x 5,30 x 153 mm

Packnorm 2 Stk. · Packaging unit 2 pcs. **20 1406**

35 mm Nitto/Universal 19 mm 3/4"

Weldon + Nitto/Universal 19 mm 3/4"

75 mm

7,98 x 6,34 x 5,30 x 178 mm

Packnorm 2 Stk. · Packaging unit 2 pcs. **20 1407**

35 mm Nitto/Universal 19 mm 3/4"

Weldon + Nitto/Universal 19 mm 3/4"

100 mm

7,98 x 6,34 x 5,30 x 203 mm

Packnorm 2 Stk. · Packaging unit 2 pcs. **20 1411**

Ersatz-Innensechskantschrauben für alle Verlängerungen siehe Seite 550
Spare allen screws for all extensions see page 550

ZUBEHÖR • SETS • DISPLAYS • ERSATZTEILE / ACCESSORIES • SETS • DISPLAYS • SPARE PARTS

Aufnahmelhalter mit Morsekonus 2 / 3 / 4 / 5 und Reduzierhülsen **541-543**
Tool holders with morse taper 2 / 3 / 4 / 5 and reduction sleeves

Kegelsenker mit Weldonschaft **544/545**
Countersinks with Weldon shank

Spiralbohradapter Weldon + Spiralbohrer Ø 4-12 mm **648**
Twist drill adaptors Weldon + twist drills Ø 4-12 mm

Gewindeadapter Weldon + Gewindebohrer M 6 - M 30 **649-650**
Tapping adapter Weldon + taps M 6 - M 30

Adapter + passende Bohrfutter **548**
Adapters + suitable drill chucks

Kühlmittel-Druckflaschen **548**
Coolant pressure bottles

Magnetstab zur Entfernung der Bohrspäne **549**
Magnetic stick for chip removal

Sets · Displays **553-582**
Sets · Displays

Ersatzteile **550-552**
Spare parts



20 1925

GOLD-DRILL LINE
ZOLL / INCH 80

HSS-XE Kernbohrer, Weldonschaft, Nutzlänge 80 mm
HSS-XE annular cutter, Weldon shank, drill depth 80 mm | 3"



ANWENDUNG • APPLICATION

Stahl	Edelstahl	Grauguss	Alu	Kupfer, Messing, Zinn	Kunststoffe GFK/CFK	Hardox 400, 450
Steel	Stainless	Grey cast iron	Alu	Copper, brass, tin	Plastics GRP/CRP	Hardox 400, 450
< 900 N	< 900 N		< 10% Si			

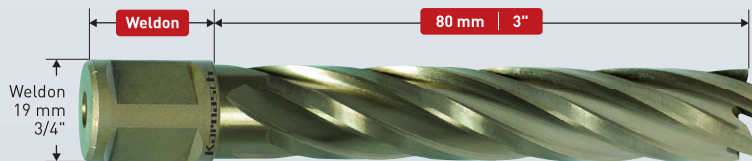

Zoll/Inch	Ø mm	Art.	Zoll/Inch	Ø mm	Art.	Zoll/Inch	Ø mm	Art.	Zoll/Inch	Ø mm	Art.
• 11/16"	17,46	20 1925 025	• 1.1/16"	26,98	20 1925 055	• 1.7/16"	36,51	20 1925 085	• 1.13/16"	46,03	20 1925 115
• 3/4"	19,04	20 1925 030	• 1.1/8"	28,57	20 1925 060	• 1.1/2"	38,10	20 1925 090	• 1.7/8"	47,62	20 1925 120
• 13/16"	20,63	20 1925 035	• 1.3/16"	30,13	20 1925 065	• 1.9/16"	39,68	20 1925 095	• 1.15/16"	49,21	20 1925 125
• 7/8"	22,22	20 1925 040	• 1.1/4"	31,75	20 1925 070	• 1.5/8"	41,27	20 1925 100	• 2"	50,80	20 1925 130
• 15/16"	23,81	20 1925 045	• 1.5/16"	33,33	20 1925 075	• 1.11/16"	42,86	20 1925 105	• 2.1/16"	52,38	20 1925 135
• 1"	25,40	20 1925 050	• 1.3/8"	34,92	20 1925 080	• 1.3/4"	44,45	20 1925 110			

Achtung: Die Zollabmessungen entsprechen nicht exakt den mm Durchmesser.
Attention: The inch sizes do not correspond exactly to the mm diameters.

20 1925

GOLD-DRILL LINE
ZOLL / INCH 80

ZUBEHÖR • ACCESSORIES



AUSWERFERSTIFTE 1-TEILIG • EJECTOR PINS 1-PIECE

• 20 1439



1-teilig / 1 piece

Packnorm 2 Stk. · Packaging unit 2 pcs.

Zusammen mit Aufnahmehalter 20 1842, 20 1291, 20 1843, 20 1845, 20 1846 (siehe Seite 542–543) kann dieser einteilige Auswerferstift verwendet werden. Es kann ohne Umstecken bis 110 mm Schnitttiefe in einem Arbeitsgang gebohrt werden. Robust und einfach.

It is possible to use this one-piece ejector pin in combination with tool holder article 20 1842, 20 1291, 20 1843, 20 1845, 20 1846 (see page 542–543). You can drill as deep as 110 mm in one working process without changing. Robust and easy.

AUSWERFERSTIFTE 2-TEILIG EJECTOR PINS 2-PIECE

• 20 1427



2-teilig / 2 piece

Packnorm 2 Stk. · Packaging unit 2 pcs.

ANWENDUNG AUSWERFERSTIFTE 2-TEILIG APPLICATION EJECTOR PINS 2-PIECE



Anwendung:

Teil 1 in den Schaft des Kernbohrers einführen. Teil 2 auf Teil 1 schieben. Bohren Sie bis ca. 50 mm Schnitttiefe. Danach Teil 2 entfernen und weiter bohren.

Application:

Insert piece 1 into the annular cutter shank. Push piece 2 onto part 1. Drill as deep as 50 mm cutting depth. Then remove piece 2 and continue drilling.

• **Warum 2-teilige Auswerferstifte?** In der Regel haben Standard Morsekonus-Aufnahmehalter eine Schnitttiefenkapazität von 50 mm. Wenn **keine extra langen** Aufnahmehalter verwendet werden (wie auf Seite 542–543 Art. 20 1842, 20 1291, 20 1843, 20 1845, 20 1846), müssen bei Schnitttiefen über 50 mm 2-teilige Auswerferstifte verwendet werden.

• **Why use 2-part ejector pins?** Usually, standard morse taper holders have a cutting depth capacity of 50 mm. If **no extra-long** holders are used (e.g. as on page 542–543 Art. 20 1842, 20 1291, 20 1843, 20 1845, 20 1846), you need for drill depths above 50 mm 2-part ejector pins.

Schnittdaten
Cutting data

Film
Movie



1488



Zubehör für HSS-XE Kernbohrer, Weldonschaft, Nutzlänge 80 mm
 Accessories for HSS-XE annular cutter, Weldon shank, drill depth 80 mm | 3"

GOLD-DRILL LINE 80
 ZOLL / INCH

20 1925

ADAPTER + PASSENDE AUSWERFERSTIFTE • ADAPTER + SUITABLE EJECTOR PINS



• **20 1161**



• **20 1314**



• **20 1436**



• **20 1436**

Packnorm 2 Stk. • Packaging unit 2 pcs.

Packnorm 2 Stk. • Packaging unit 2 pcs.



• **21 0048**



• **20 1439**

Packnorm 2 Stk. • Packaging unit 2 pcs.

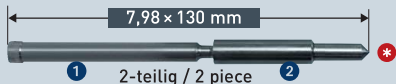

• **20 1427**

Packnorm 2 Stk. • Packaging unit 2 pcs.

Ersatz-Innensechskantschrauben für alle Adapter siehe Seite 550
 Spare allen screws for all adapters see page 550

ZUBEHÖR • SETS • DISPLAYS • ERSATZTEILE / ACCESSORIES • SETS • DISPLAYS • SPARE PARTS

Aufnahmehalter mit Morsekonus 2 / 3 / 4 / 5 und Reduzierhülsen  541-543
 Tool holders with morse taper 2 / 3 / 4 / 5 and reduction sleeves



Kühlmittel-Druckflaschen  548
 Coolant pressure bottles



Kegelsenker mit Weldonschaft  544/545
 Countersinks with Weldon shank

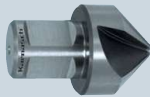

Magnetstab zur Entfernung der Bohrspäne  549
 Magnetic stick for chip removal



Spiralbohradapter Weldon + Spiralbohrer Ø 2,5-12 mm  648
 Twist drill adaptors Weldon + twist drills Ø 2,5-12 mm



Sets • Displays  553-582
 Sets • Displays



Gewindeadapter Weldon + Gewindebohrer M 3 - M 30  649-650
 Tapping adapter Weldon + taps M 3 - M 30



Adapter + passende Bohrfutter  548
 Adapters + suitable drill chucks

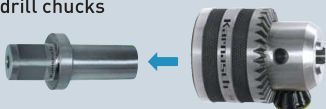

Ersatzteile  550-552
 Spare parts

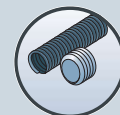

- 1
- 2
- 3
- 4
- 5
- 6
- 7
- 8
- 9
- 10

HSS-XE KERNBOHRER HSS-XE ANNULAR CUTTERS

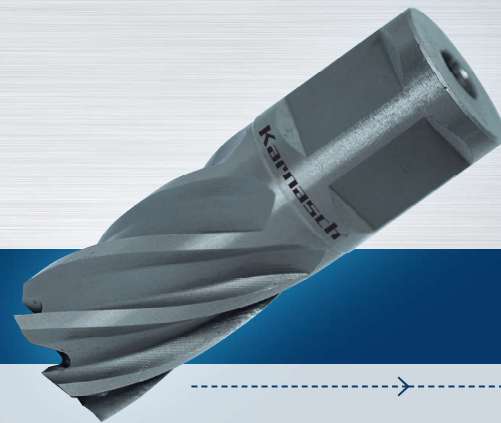

SILVER-DRILL LINE

Karnasch SILVER-DRILL LINE Kernbohrer ist ein hervorragender Universalbohrer.

HSS-XE Spezialstahl + Stufenhärtung + bis zu 7 verschiedene Schneidgeometrien geeignet zum Bohren aller Baustähle bis 35 Rockwell (HRC).

Karnasch SILVER-DRILL LINE annular cutter is an excellent UNIVERSAL DRILL.

HSS-XE special steel + Step hardened + up to 7 different cutting geometries suitable for drilling of all mild steels up to a strength of 35 Rockwell (HRC).

EIGENSCHAFTEN · PROPERTIES



Gefertigt aus hochlegiertem HSS-XE Spezialstahl. Für extreme Härte an den Zahnspitzen (bis 68 HRC). Somit hohe Verschleißfestigkeit und Standzeit.

Made of high-alloyed HSS-XE special steel. For extreme hardness at the tip of the tooth (up to 68 HRC). A high wear resistance and lifetime.



Nur wenige Hersteller sind in der Lage in Stufen gehärtete Kernbohrer zu fertigen. Für uns ist dies „Standard“. Dadurch erreichen wir extrem harte Zahnspitzen (68 HRC) und dennoch einen flexiblen Kernbohrer.

Only few manufacturers are capable of producing step-hardened annular cutters. For Karnasch this is "standard". Only this makes us produce extremely hard tooth tips (68 HRC) and yet a flexible annular cutter.



Sieben verschiedene Schneidgeometrien optimiert je nach Durchmesser und Schnitttiefe des Kernbohrers, ergeben höchste Zerspanleistung.

Seven different cutting geometries optimally adapted to the different diameter and drill depths leads to high performance cutting results.

ANWENDUNG · APPLICATION

Stahl	Stahl	Alu	Kupfer, Messing, Zinn	Kunststoffe GFK/CFK
Steel	Steel	Alu	Copper, brass, tin	Plastics GRP/CRP
< 750 N	< 900 N	< 10% Si		
✓	✓	✓	✓	✓

✓ OPTIMAL · OPTIMAL

✓ GUT · GOOD

✓ MÖGLICH · POSSIBLE

HSS-XE KERNBOHRER HSS-XE ANNULAR CUTTERS

SILVER-DRILL LINE

Schnitttiefe · Drill depths

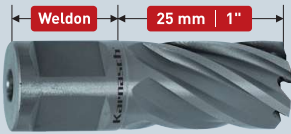

**BEST
SELLER**

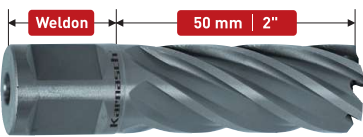

**BEST
SELLER**

Ø mm	Ø Zoll/Inch	Art. / Type	
12-60	15/32- 2.23/64"	20 1255 SILVER-DRILL LINE/25	438
12-60	15/32- 2.23/64"	20 1265 SILVER-DRILL LINE/50	440

ZUBEHÖR · SETS · DISPLAYS · ERSATZTEILE / ACCESSORIES · SETS · DISPLAYS · SPARE PARTS

Aufnahmehalter mit Morsekonus 2 / 3 / 4 / 5 und Reduzierhülsen 541-543
Tool holders with morse taper 2 / 3 / 4 / 5 and reduction sleeves



Kühlmittel-Druckflaschen 548
Coolant pressure bottles



Kegelsenker mit Weldonchaft 544/545
Countersinks with Weldon shank

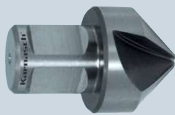

Magnetstab zur Entfernung der Bohrspäne 549
Magnetic stick for chip removal



Spiralbohradapter Weldon + Spiralbohrer Ø 2,5-12 mm 648
Twist drill adaptors Weldon + twist drills Ø 2,5-12 mm



Sets · Displays 553-582
Sets · Displays



Gewintheadapter Weldon + Gewindebohrer M 3 - M 30 649-650
Tapping adapter Weldon + taps M 3 - M 30



Vollhartmetall Gewindebohrer-Ausbohrer 652
Solid carbide drills to remove jammed taps



Adapter + passende Bohrfutter 548
Adapters + suitable drill chucks

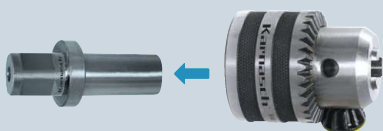

Ersatzteile 550-552
Spare parts

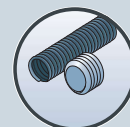

- 1
- 2
- 3
- 4
- 5
- 6
- 7
- 8
- 9
- 10

20 1255

SILVER-DRILL LINE / 25

HSS-XE Kernbohrer, Weldonschaft, Nutzlänge 25 mm
HSS-XE annular cutter, Weldon shank, drill depth 25 mm | 1"



ANWENDUNG • APPLICATION

Stahl Steel	Alu Alu	Kupfer, Messing, Zinn Copper, brass, tin	Kunststoffe GFK/CFK Plastics GRP/CRP
< 750 N	< 10% Si		

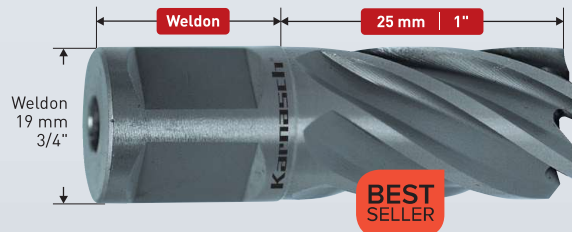

Bestseller – preisreduziert • Bestseller – price reduced

Art.	Ø mm	Ø Zoll Inch
20 1255 012	• 12	15/32"
20 1255 013	• 13	33/64"
20 1255 014	• 14	35/64"
20 1255 015	• 15	19/32"
20 1255 016	• 16	5/8"
20 1255 017	• 17	43/64"
20 1255 018	• 18	45/64"
20 1255 019	• 19	3/4"
20 1255 020	• 20	25/32"
20 1255 021	• 21	53/64"
20 1255 022	• 22	55/64"
20 1255 023	• 23	29/32"
20 1255 024	• 24	15/16"
20 1255 025	• 25	63/64"

Art.	Ø mm	Ø Zoll Inch
20 1255 026	• 26	1.1/32"
20 1255 027	• 27	1.1/16"
20 1255 028	• 28	1.7/64"
20 1255 029	• 29	1.9/64"
20 1255 030	• 30	1.3/16"
20 1255 031	• 31	1.7/32"
20 1255 032	• 32	1.17/64"
20 1255 033	• 33	1.19/64"
20 1255 034	• 34	1.11/32"
20 1255 035	• 35	1.3/8"
20 1255 036	• 36	1.27/64"
20 1255 037	• 37	1.29/64"
20 1255 038	• 38	1.1/2"
20 1255 039	• 39	1.17/32"

Art.	Ø mm	Ø Zoll Inch
20 1255 040	• 40	1.37/64"
20 1255 041	• 41	1.39/64"
20 1255 042	• 42	1.21/32"
20 1255 043	• 43	1.11/16"
20 1255 044	• 44	1.47/64"
20 1255 045	• 45	1.49/64"
20 1255 046	• 46	1.13/16"
20 1255 047	• 47	1.27/32"
20 1255 048	• 48	1.57/64"
20 1255 049	• 49	1.59/64"
20 1255 050	• 50	1.31/32"
20 1255 051	• 51	2.1/64"
20 1255 052	• 52	2.3/64"
20 1255 053	• 53	2.3/32"

Art.	Ø mm	Ø Zoll Inch
20 1255 054	• 54	2.1/8"
20 1255 055	• 55	2.11/64"
20 1255 056	• 56	2.13/64"
20 1255 057	• 57	2.1/4"
20 1255 058	• 58	2.9/32"
20 1255 059	• 59	2.21/64"
20 1255 060	• 60	2.23/64"

Größere Ø siehe Art. 20 1315 Seite 382 sowie Art. 20 1316 Seite 384 -
Achtung: Die Zollabmessungen entsprechen nicht exakt den mm Durchmessern.
Larger Ø see Art. 20 1315 page 382 and Art. 20 1316 page 384 -
Attention: The inch sizes do not correspond exactly to the mm diameters.

20 1255

SILVER-DRILL LINE / 25

ZUBEHÖR • ACCESSORIES



AUSWERFERSTIFTE • EJECTOR PINS



• 20 1221

Packnorm 2 Stk. - Packaging unit 2 pcs.

20 1255

SILVER-DRILL LINE / 25

SETS / DISPLAYS Seite / Page 566



Wir bieten eine große Auswahl an Sets / Displays – Inhaltsvorschläge 20 1255 SILVER-DRILL LINE 25 – siehe Seite 566. Anderer Inhalt auf Wunsch möglich, durch individuell bestückbare Sets / Displays.
We offer a large selection of sets / displays – recommended content 20 1255 SILVER-DRILL LINE 25 – see page 566. Other content possible by individually equipped sets / displays.



Schnittdaten
Cutting data

Film
Movie



1488

- 1
- 2
- 3
- 4
- 5
- 6
- 7
- 8
- 9
- 10

Zubehör für HSS-XE Kernbohrer, Weldonschaft, Nutzlänge 25 mm
Accessories for HSS-XE annular cutter, Weldon shank, drill depth 25 mm | 1"

SILVER-DRILL LINE 25

20 1255

ADAPTER + PASSENDE AUSWERFERSTIFTE
ADAPTER + SUITABLE EJECTOR PINS

FEIN Quick-In 18 mm
Weldon + Nitto/Universal 19 mm 3/4"



6,34 x 102 mm

Packnorm 2 Stk. · Packaging unit 2 pcs.

20 1263

20 1271

Nitto/Universal 19 mm 3/4"

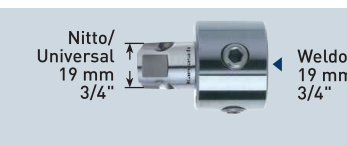

Weldon 19 mm 3/4"

6,34 x 102 mm

Packnorm 2 Stk. · Packaging unit 2 pcs.

20 1311

20 1271

Weldon 32 mm 1.1/4"



Weldon + Nitto/Universal 19 mm 3/4"

6,34 x 77 mm

Packnorm 2 Stk. · Packaging unit 2 pcs.

21 0048

20 1221

Ersatz-Innensechskantschrauben für alle Adapter siehe Seite 550
Spare allen screws for all adapters see page 550

VERLÄNGERUNGEN + PASSENDE AUSWERFERSTIFTE
EXTENSIONS + SUITABLE EJECTOR PINS

Weldon 19 mm 3/4"

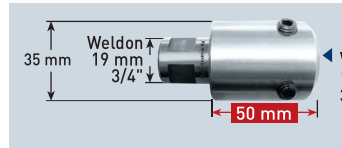

Weldon + Nitto/Universal 19 mm 3/4"

35 mm

50 mm

7,98 x 6,34 x 5,30 x 127 mm

Packnorm 2 Stk. · Packaging unit 2 pcs.

20 1387

20 1433

Weldon 19 mm 3/4"

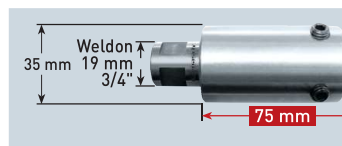

Weldon + Nitto/Universal 19 mm 3/4"

35 mm

75 mm

7,98 x 6,34 x 5,30 x 153 mm

Packnorm 2 Stk. · Packaging unit 2 pcs.

20 1402

20 1396

Weldon 19 mm 3/4"

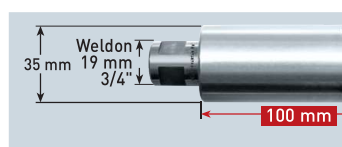

Weldon + Nitto/Universal 19 mm 3/4"

35 mm

100 mm

7,98 x 6,34 x 5,30 x 178 mm

Packnorm 2 Stk. · Packaging unit 2 pcs.

20 1417

20 1411

Ersatz-Innensechskantschrauben für alle Verlängerungen siehe Seite 550
Spare allen screws for all extensions see page 550

ZUBEHÖR · SETS · DISPLAYS · ERSATZTEILE / ACCESSORIES · SETS · DISPLAYS · SPARE PARTS

Aufnahmehalter mit Morsekonus 2 / 3 / 4 / 5 und Reduzierhülsen
Tool holders with morse taper 2 / 3 / 4 / 5 and reduction sleeves



541-543

Kühlmittel-Druckflaschen
Coolant pressure bottles



548

Kegelsenker mit Weldonschaft
Countersinks with Weldon shank



544/545

Magnetstab zur Entfernung der Bohrspäne
Magnetic stick for chip removal



549

Spiralbohradapter Weldon + Spiralbohrer Ø 2,5-12 mm
Twist drill adaptors Weldon + twist drills Ø 2,5-12 mm

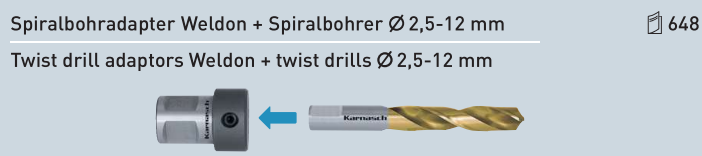

648

Sets · Displays
Sets · Displays



553-582

Gewindeadapter Weldon + Gewindebohrer M 3 - M 30
Tapping adapter Weldon + taps M 3 - M 30

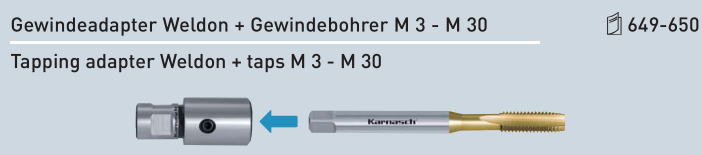

649-650

Adapter + passende Bohrfutter
Adapters + suitable drill chucks

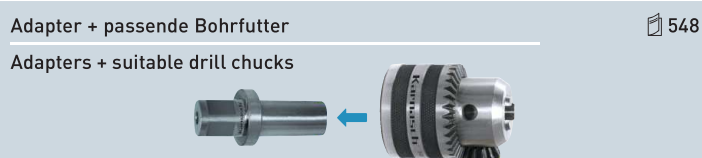

548

Ersatzteile
Spare parts

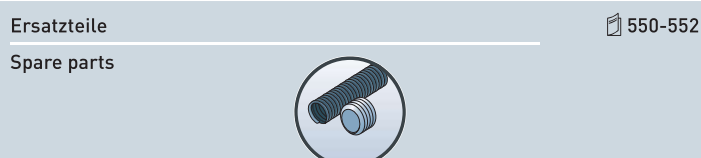

550-552



20 1265

SILVER-DRILL LINE / 50

HSS-XE Kernbohrer, Weldonschaft, Nutzlänge 50 mm
HSS-XE annular cutter, Weldon shank, drill depth 50 mm | 2"



ANWENDUNG • APPLICATION

Stahl Steel	Alu Alu	Kupfer, Messing, Zinn Copper, brass, tin	Kunststoffe GFK/CFK Plastics GRP/CRP
< 750 N	< 10% Si		



Bestseller – preisreduziert • Bestseller – price reduced

Art.	Ø mm	Ø Zoll Inch
20 1265 012	• 12	15/32"
20 1265 013	• 13	33/64"
20 1265 014	• 14	35/64"
20 1265 015	• 15	19/32"
20 1265 016	• 16	5/8"
20 1265 017	• 17	43/64"
20 1265 018	• 18	45/64"
20 1265 019	• 19	3/4"
20 1265 020	• 20	25/32"
20 1265 021	• 21	53/64"
20 1265 022	• 22	55/64"
20 1265 023	• 23	29/32"
20 1265 024	• 24	15/16"
20 1265 025	• 25	63/64"

Art.	Ø mm	Ø Zoll Inch
20 1265 026	• 26	1.1/32"
20 1265 027	• 27	1.1/16"
20 1265 028	• 28	1.7/64"
20 1265 029	• 29	1.9/64"
20 1265 030	• 30	1.3/16"
20 1265 031	• 31	1.7/32"
20 1265 032	• 32	1.17/64"
20 1265 033	• 33	1.19/64"
20 1265 034	• 34	1.11/32"
20 1265 035	• 35	1.3/8"
20 1265 036	• 36	1.27/64"
20 1265 037	• 37	1.29/64"
20 1265 038	• 38	1.1/2"
20 1265 039	• 39	1.17/32"

Art.	Ø mm	Ø Zoll Inch
20 1265 040	• 40	1.37/64"
20 1265 041	• 41	1.39/64"
20 1265 042	• 42	1.21/32"
20 1265 043	• 43	1.11/16"
20 1265 044	• 44	1.47/64"
20 1265 045	• 45	1.49/64"
20 1265 046	• 46	1.13/16"
20 1265 047	• 47	1.27/32"
20 1265 048	• 48	1.57/64"
20 1265 049	• 49	1.59/64"
20 1265 050	• 50	1.31/32"
20 1265 051	• 51	2.1/64"
20 1265 052	• 52	2.3/64"
20 1265 053	• 53	2.3/32"

Art.	Ø mm	Ø Zoll Inch
20 1265 054	• 54	2.1/8"
20 1265 055	• 55	2.11/64"
20 1265 056	• 56	2.13/64"
20 1265 057	• 57	2.1/4"
20 1265 058	• 58	2.9/32"
20 1265 059	• 59	2.21/64"
20 1265 060	• 60	2.23/64"

% Sonderpreis / Sale Artikel.
Lieferbar solange Vorrat.
Special price / sale article.
While stocks last.

Größere Ø siehe Art. 20 1316 Seite 384.

Achtung: Die Zollabmessungen entsprechen nicht exakt den mm Durchmessern.

Larger Ø see Art. 20 1316 page 384.

Attention: The inch sizes do not correspond exactly to the mm diameters.

20 1265

SILVER-DRILL LINE / 50

ZUBEHÖR • ACCESSORIES



AUSWERFERSTIFTE • EJECTOR PINS

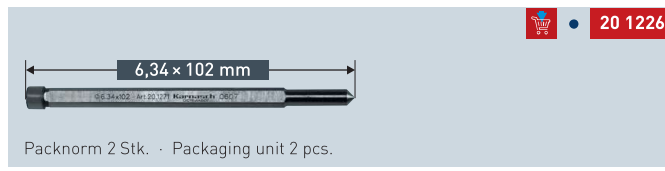

20 1265

SILVER-DRILL LINE / 50

SETS / DISPLAYS Seite / Page 567

Wir bieten eine große Auswahl an Sets / Displays – Inhaltsvorschläge 20 1265 SILVER-DRILL LINE50 – siehe Seite 567. Anderer Inhalt auf Wunsch möglich, durch individuell bestückbare Sets / Displays.

We offer a large selection of sets / displays – recommended content 20 1265 SILVER-DRILL LINE50 – see page 567. Other content possible by individually equipped sets / displays.



Schnittdaten
Cutting data

Film
Movie



1488

Zubehör für HSS-XE Kernbohrer, Weldonschaft, Nutzlänge 50 mm
 Accessories for HSS-XE annular cutter, Weldon shank, drill depth 50 mm | 2"

SILVER-DRILL LINE 50

20 1265

ADAPTER + PASSENDE AUSWERFERSTIFTE
ADAPTER + SUITABLE EJECTOR PINS

FEIN Quick-In 18 mm
 Weldon + Nitto/Universal 19 mm 3/4"

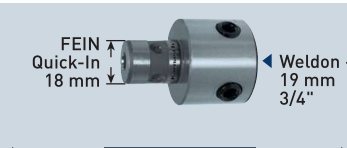

6,34 x 130 mm

Packnorm 2 Stk. · Packaging unit 2 pcs.

20 1263

20 1160

Nitto/Universal 19 mm 3/4"
 Weldon 19 mm 3/4"

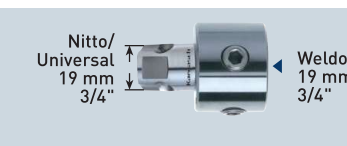

6,34 x 130 mm

Packnorm 2 Stk. · Packaging unit 2 pcs.

20 1311

20 1160

Weldon 32 mm 1.1/4"
 Weldon + Nitto/Universal 19 mm 3/4"



6,34 x 102 mm

Packnorm 2 Stk. · Packaging unit 2 pcs.

21 0048

20 1226

Ersatz-Innensechskantschrauben für alle Adapter siehe Seite 550
 Spare allen screws for all adapters see page 550

VERLÄNGERUNGEN + PASSENDE AUSWERFERSTIFTE
EXTENSIONS + SUITABLE EJECTOR PINS

Weldon 19 mm 3/4"
 Weldon + Nitto/Universal 19 mm 3/4"

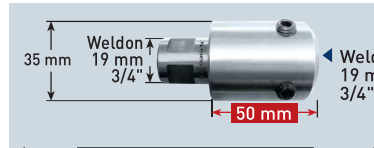

35 mm

50 mm

7,98 x 6,34 x 5,30 x 153 mm

Packnorm 2 Stk. · Packaging unit 2 pcs.

20 1387

20 1396

Weldon 19 mm 3/4"
 Weldon + Nitto/Universal 19 mm 3/4"

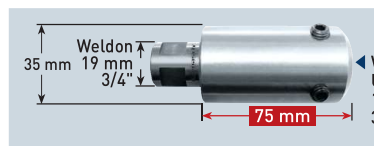

35 mm

75 mm

7,98 x 6,34 x 5,30 x 178 mm

Packnorm 2 Stk. · Packaging unit 2 pcs.

20 1402

20 1411

Weldon 19 mm 3/4"
 Weldon + Nitto/Universal 19 mm 3/4"

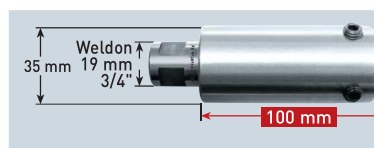

35 mm

100 mm

7,98 x 6,34 x 5,30 x 203 mm

Packnorm 2 Stk. · Packaging unit 2 pcs.

20 1417

20 1426

Ersatz-Innensechskantschrauben für alle Verlängerungen siehe Seite 550
 Spare allen screws for all extensions see page 550

ZUBEHÖR · SETS · DISPLAYS · ERSATZTEILE / ACCESSORIES · SETS · DISPLAYS · SPARE PARTS

Aufnahmehalter mit Morsekonus 2 / 3 / 4 / 5 und Reduzierhülsen 541-543
 Tool holders with morse taper 2 / 3 / 4 / 5 and reduction sleeves



Kühlmittel-Druckflaschen 548
 Coolant pressure bottles



Kegelsenker mit Weldonschaft 544/545
 Countersinks with Weldon shank



Magnetstab zur Entfernung der Bohrspäne 549
 Magnetic stick for chip removal



Spiralbohradapter Weldon + Spiralbohrer Ø 2,5-12 mm 648
 Twist drill adaptors Weldon + twist drills Ø 2,5-12 mm

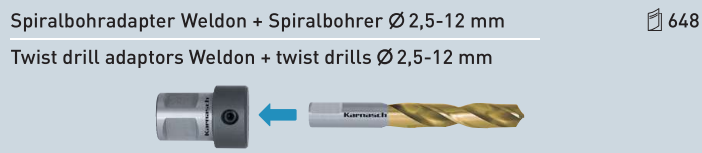

Sets · Displays 553-582
 Sets · Displays



Gewindeadapter Weldon + Gewindebohrer M 3 - M 30 649-650
 Tapping adapter Weldon + taps M 3 - M 30

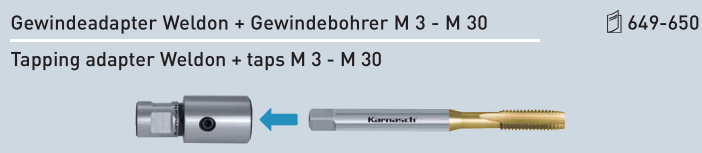

Adapter + passende Bohrfutter 548
 Adapters + suitable drill chucks



Ersatzteile 550-552
 Spare parts

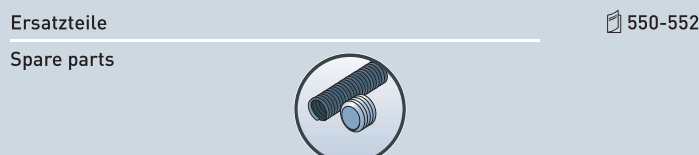

20 1230

MINI-LINE / 8

Kernbohrer / Lochsägen Kombination, Weldonschaft, Nutzlänge 8 mm
Annular cutter / hole saw combination, Weldon shank, drill depth 8 mm | 5/16"



ANWENDUNG · APPLICATION

Stahl Steel	Edelstahl Stainless	Alu Alu	Kupfer, Messing, Zinn Copper, brass, tin	Kunststoffe GFK/CFK Plastics GRP/CRP
< 900 N	> 900 N	< 10% Si		

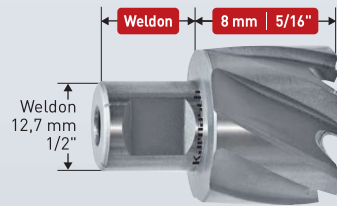

ZUBEHÖR
ACCESSORIES

Art.	Ø mm	Ø Zoll Inch	Art.	Ø mm	Ø Zoll Inch	Art.	Ø mm	Ø Zoll Inch
20 1230 008	• 8	5/16"	20 1230 014	• 14	35/64"	20 1230 022	• 22	55/64"
20 1230 010	• 10	25/64"	20 1230 016	• 16	5/8"	20 1230 024	• 24	15/16"
20 1230 012	• 12	15/32"	20 1230 018	• 18	45/64"	20 1230 025	• 25	63/64"
20 1230 013	• 13	33/64"	20 1230 020	• 20	25/32"			

Achtung: Die Zollabmessungen entsprechen nicht exakt den mm Durchmesser.

Attention: The inch sizes do not correspond exactly to the mm diameters.

EIGENSCHAFTEN · PROPERTIES

HSS-XE Stahl Kernbohrer / Lochsägen Kombination in Leichtlauf Ausführung für handgeführte Maschinen, Kernbohrmaschinen, Stationäre Maschinen.

Das ideale Bohrwerkzeug für:

- Elektriker
- Sanitär- und Heizungsbauer
- Blechbearbeitung
- Wartungsinstallationen
- Automobil-Blecharbeiten und vieles mehr...

Durch dünne Schnittbreite von nur 2,8 mm:

- Sehr wenig Schnittdruck für lange Lebensdauer bei Arbeiten mit Akku-Bohrmaschinen.
- Schnelles und leichtgängiges Bohren aller Durchmesser
- Exzellente Führung und Kontrolle während des Bohrvorgangs.

Schnitttiefen:

Bis zu 8 mm möglich bei Stahl/Edelstahl. Bis zu 8 mm möglich bei NE-Metallen (Alu), Kunststoffen, Sandwich-Material.

Anwendungshinweis:

Verwenden Sie bei allen Metallen gutes Schneidöl (siehe ab Seite 1265)

HSS-XE steel annular cutter / hole saw combination for handeld machines, core drilling machines, stationary machines.

The ideal drilling tool for:

- Electrical
- Piping
- Conduit work
- Sheet metal fabrication
- Maintenance installation
- HVAC & PHCC
- Automotive service and many other industries.

Because of thin cutting width of only 2,8 mm:

- Very little cutting pressure for long battery life if using cordless drilling machines.
- Fast and smooth running drilling of all diameters.
- Excellent guidance and control during drilling.

Drill depths:

Up to 8 mm possible in steel/stainless steel. Up to 8 mm possible in non-ferrous metal (Alu), plastics, sandwich material.

Application note:

Use only good cutting oil. For metal (see from page 1265)

Schnittdaten
Cutting data

Film
Movie



1488



Zubehör Kernbohrer / Lochsägen Kombination, Weldonschaft, Nutzlänge 8 mm

Accessories for annular cutter / hole saw combination, Weldon shank, drill depth 8 mm | 5/16"

MINI-LINE / 8

20 1230



HANDMASCHINEN
HANDHELD MACHINES

STATIONÄRE MASCHINEN
STATIONARY MACHINES



SCHAFT + PASSENDER AUSWERFERSTIFT
SHANK + SUITABLE EJECTOR PIN



• 20 1235

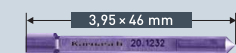

• 20 1232

SETS · SETS



• 20 1251

Inhalt · Content

11 Stk./Pcs. → Ø 8, 10, 12, 13, 14, 16, 18, 20, 22, 24, 25 mm +

Schaft · Shank	• 20 1235
Auswerferstift · Ejector pin	• 20 1232
Adapter · Adapter	• 20 1234
Auswerferstift · Ejector pin	• 20 1233
Körner · Punch	• 20 1238
Inbusschlüssel · Allen key	• 20 1239

Anderer Inhalt möglich!

Other content possible!

Leeres Set • 20 1377
Empty set



MAGNET-KERNBOHRMASCHINEN
MAGNETIC HOLE CUTTING MACHINES

ADAPTER + PASSENDE AUSWERFERSTIFTE
ADAPTER + SUITABLE EJECTOR PINS

WELDON 19 mm (3/4")

Passend für Maschinen · Suitable for machines

Karnasch · Alfa-Rotabest + Alfa Rotaquick · BDS + BDS Keyless · Bektop · Bux · Cembre · Dubuis · Erico · Euroboor · Evolution · Hall (Powerbor) · Hougen · Jancy · Magbroach · Magtron · Magnetor · Metallkraft · Promag · Ruko · Rotabroach · Ruko + Ruko Easylock · Universal ...

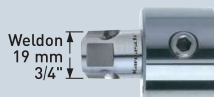

• 20 1234

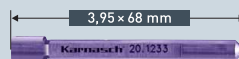

• 20 1233

ERSATZTEILE · SPARE PARTS

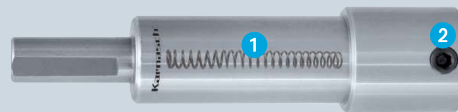

1 Auswurfeder · Ejector spring



• 12 x 55 mm • 20 1237

2 Schraube · Screw



• Ø 3 mm / M 6 x 6 • 20 1330

FUNKTIONSWEISE · OPERATING MODE

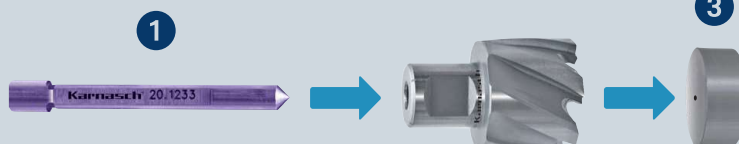
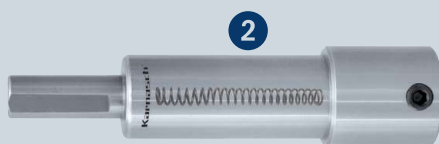

- Das Werkstück ankören. Es ist wichtig mit dem Körner einen starken Körnerpunkt zu setzen (speziell bei Handmaschinen).
- Setzen Sie den Auswerferstift 1 genau in die Mitte des starken Körnerpunktes an. Zu Beginn des Bohrprozesses wenig Druck (Vorschub) verwenden, bis der Bohrer zirka 0,5 mm Schnitttiefe erreicht hat. Der Bohrer hat sich nun selbst zentriert. Der Vorschub kann erhöht werden.
- Eine Auswurfeder im Schaft 2 erzeugt Druck auf den Auswerferstift 1.
- Der Auswerferstift wirft den Kern 3 nach dem Durchbohren aus.

- Center punch the workpiece. It is important to set a strong center mark (especially if using handheld machines).
- Place the ejector pin 1 exactly in the middle of the strong center mark. Use little pressure (feed-rate) until you reach approximately 0,5 mm cutting depth. The drill is self-centered now. You can increase feed rate.
- An ejection spring 2 which is installed in the shank puts pressure on the ejector pin 1.
- The ejector pin ejects the core 3 after drilling process.

1



2



3



4



5



6



7



8



9



10



PULVERSTAHL + DURABLUE-BESCHICHTETE SPIRALBOHRER POWDER STEEL + DURABLUE-COATED TWIST DRILLS



DRILL-LINE PRO

Im harten Einsatz kann nur in den seltensten Fällen auf optimale Drehzahlen und Kühlung Rücksicht genommen werden. Die Karnasch DURABLUE-Beschichtung macht den Kernbohrer somit entscheidend widerstandsfähiger. Letztendlich wird dadurch die Lebensdauer des Bohrers wesentlich erhöht.

DRILL-LINE PRO Spiralbohrer sind der Problemlöser für schwierigste Zerspanungsprobleme. Bohren in Stähle bis 45 Rockwell (HRC). Für weniger schwierige Zerspanung siehe Art. 20 1710 Seite 448, Art. 20 1840 Seite 449

Under hard field conditions only in the rarest cases optimum speed and cooling can be considered. The Karnasch DURABLUE-coating makes the annular cutter decisively more resistant. This results in a considerable increase in product life.

DRILL-LINE PRO twist drill are the right choice for most difficult materials. Drilling in steel up to 45 Rockwell (HRC). For less difficult materials see Art. 20 1710 page 448, Art. 20 1840 page 449

EIGENSCHAFTEN · PROPERTIES



Gefertigt aus ASP Pulverstahl zum Bohren auch schwierigster Materialien wie Eisenbahnschienen, Edelstähle, exotische Legierungen. Immer dort einsetzbar wo höchste Verschleißfestigkeit und Standzeit benötigt wird.

Made of ASP powder steel for drilling of difficult materials like railway tracks, stainless steels, exotic alloys. Applicable wherever a high wear resistance and lifetime are required.

Karnasch Spiralbohrer werden mit einer Hochleistungsgeometrie gefertigt für: Sofortiges Selbstzentrieren, leichteres Zerspanen, höchste Standzeiten.

Karnasch twist drills are produced in a heavy-duty geometry for immediate self-centering, easy cutting, highest lifetimes.

Unsere hochwertigsten Spiralbohrer erhalten die einzigartige und patentierte DURABLUE-Beschichtung. Extreme Oberflächenhärte- und -glätte ergeben extreme Standzeiten auch unter nicht optimalen Arbeitsbedingungen wie „Über Kopf arbeiten“, Trockenbohrungen, u.s.w.

Our first-class twist drills are equipped with the unique and patented DURABLUE-coating. Extreme surface hardness and sleekness yield extreme lifetimes even under non-optimum conditions like "overhead work", dry drilling, etc.

ANWENDUNG · APPLICATION

Stahl	Stahl	Edelstahl	Alu	Kupfer, Messing, Zinn	Kunststoffe GFK/CFK	Grauguss	Graphit	Hastelloy, Inconel, Nimonic, Exotische Materialien	Schienen	Hardox 400
Steel	Steel	Stainless	Alu	Copper, brass, tin	Plastics GRP/CRP	Grey cast iron	Graphite	Hastelloy, Inconel, Nimonic, exotic materials	Rails	Hardox 400
< 1100 N	< 1400 N	> 900 N	> 10% Si							
✓	✓	✓	✓	✓	✓	✓	✓	✓	✓	✓

✓ OPTIMAL · OPTIMAL

✓ GUT · GOOD

✓ MÖGLICH · POSSIBLE

PULVERSTAHL + DURABLUE-BESCHICHTETE SPIRALBOHRER POWDER STEEL + DURABLUE-COATED TWIST DRILLS

DRILL-LINE PRO

Schnitttiefe · Drill depths

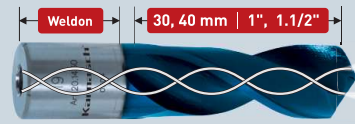

Ø mm

Ø Zoll/Inch

Art. / Type



6-27,5

15/64-
1.5/64"

20 1430

DRILL-LINE 30/40 PRO

446

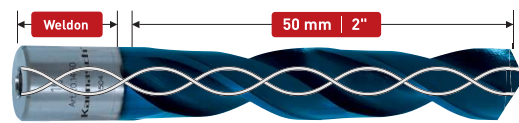

14-32

35/64-
1.17/64"

20 1465

DRILL-LINE 50 PRO

447

ZUBEHÖR · SETS · DISPLAYS · ERSATZTEILE / ACCESSORIES · SETS · DISPLAYS · SPARE PARTS

Aufnahmehalter mit Morsekonus 2 / 3 / 4 / 5 und Reduzierhülsen 541-543

Tool holders with morse taper 2 / 3 / 4 / 5 and reduction sleeves



Kühlmittel-Druckflaschen 548

Coolant pressure bottles



Kegelsenker mit Weldonschaft 544/545

Countersinks with Weldon shank

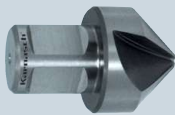

Magnetstab zur Entfernung der Bohrspäne 549

Magnetic stick for chip removal



Spiralbohradapter Weldon + Spiralbohrer Ø 2,5-12 mm 648

Twist drill adaptors Weldon + twist drills Ø 2,5-12 mm



Sets · Displays 553-582

Sets · Displays



Gewintheadapter Weldon + Gewindebohrer M 3 - M 30 649-650

Tapping adapter Weldon + taps M 3 - M 30



Vollhartmetall Gewindebohrer-Ausbohrer 652

Solid carbide drills to remove jammed taps



Adapter + passende Bohrfutter 548

Adapters + suitable drill chucks

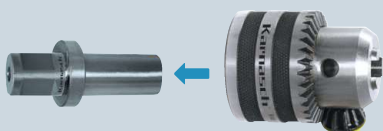

Ersatzteile 550-552

Spare parts

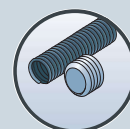

1



2



3



4



5



6



7



8



9



10



20 1430

DRILL-LINE 30 PRO



Pulverstahl + DURABLUE-beschichteter Spiralbohrer, Nutzlänge 30 mm, Weldonschaft oder Fein Quick-In Schaft
 Powder steel + DURABLUE-coated twist drill, drill depth 30 mm | 1", Weldon shank or Fein Quick-In shank

ANWENDUNG • APPLICATION

Stahl	Edelstahl	Grauguss	Alu	Kupfer, Messing, Zinn	Kunststoffe GFK/CFK	Hastelloy, Inconel, Exotische Materialien	Hardox 400
Steel	Stainless	Grey cast iron	Alu	Copper, brass, tin	Plastics GRP/CRP	Hastelloy, Inconel, exotic materials	Hardox 400
< 1400 N	> 900 N		> 10% Si				

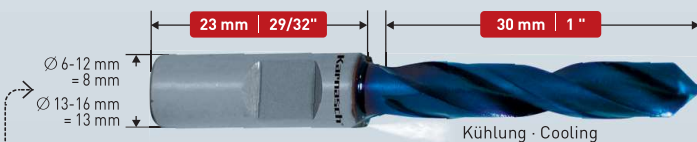

Kühlung - Cooling



Adapter siehe Zubehör
 Adapter see accessories

Art.	Ø mm	Ø Zoll Inch	Art.	Ø mm	Ø Zoll Inch
20 1430 006	6	15/64"	20 1430 013	13	33/64"
20 1430 008	8	5/16"	20 1430 0135	13,5	17/32"
20 1430 0098	9,8	25/64"	20 1430 014	14	35/64"
20 1430 010	10	25/64"	20 1430 015	15	19/32"
20 1430 011	11	7/16"	20 1430 016	16	5/8"
20 1430 012	12	15/32"			

Für Ø 6 - 16 mm benötigen Sie Adapter (siehe Zubehör).
Achtung: Die Zollabmessungen entsprechen nicht exakt den mm Durchmessern.
 For Ø 6 - 16 mm you need adapter (see accessories).
Attention: The inch sizes do not correspond exactly to the mm diameters.

ZUBEHÖR • ACCESSORY

Adapter mit Bolzen zum Öffnen der Kühlmittelzufuhr
 Adapter with pin for opening the coolant supply

WELDON 19 mm (3/4")

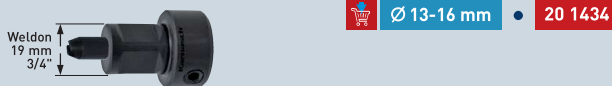

FEIN QUICK-IN



20 1430

DRILL-LINE 40 PRO



Pulverstahl + DURABLUE-beschichteter Spiralbohrer mit Innenkühlung, Nutzlänge 40 mm, Weldonschaft
 Powder steel + DURABLUE-coated twist drill with internal cooling supply, drill depth 40 mm | 1.1/2", Weldon shank

ANWENDUNG • APPLICATION

Stahl	Edelstahl	Grauguss	Alu	Kupfer, Messing, Zinn	Kunststoffe GFK/CFK	Hastelloy, Inconel, Exotische Materialien	Hardox 400
Steel	Stainless	Grey cast iron	Alu	Copper, brass, tin	Plastics GRP/CRP	Hastelloy, Inconel, exotic materials	Hardox 400
< 1400 N	> 900 N		> 10% Si				

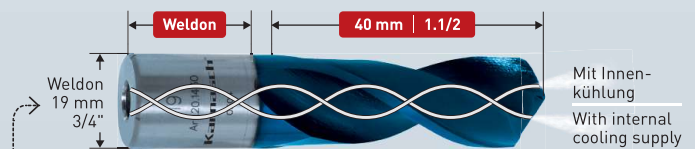

Mit Innenkühlung
 With internal cooling supply

Ø 17-27,5 mm wird ohne Bolzen zum Öffnen der Kühlmittelzufuhr geliefert (wenn benötigt siehe Zubehör).

Ø 17-27,5 mm will be delivered without pin for opening the cooling supply (see accessories if required).

Art.	Ø mm	Ø Zoll Inch	Art.	Ø mm	Ø Zoll Inch
20 1430 017	17	43/64"	20 1430 023	% 23	29/32"
20 1430 018	18	45/64"	20 1430 024	24	15/16"
20 1430 019	19	3/4"	20 1430 0275	27,5	1.5/64"
20 1430 020	20	25/32"			
20 1430 021	21	53/64"			
20 1430 022	22	55/64"			

Weitere Abmessungen sowie Schnitttiefe 50 mm siehe nächste Seite Art. 20 1465.
Achtung: Die Zollabmessungen entsprechen nicht exakt den mm Durchmessern.
 More dimensions and cutting depth 50 mm see next page art. 20 1465.
Attention: The inch sizes do not correspond exactly to the mm diameters.

% Sonderpreis / Sale Artikel. Lieferbar solange Vorrat.
 Special price / sale article. While stocks last.

ZUBEHÖR • ACCESSORY

Der Bolzen ist nur notwendig, wenn Aufnahmealter mit Innenkühlung verwendet werden (Siehe Seite 541-543).
 The pin is only necessary if you use tool holders with internal cooling supply (see page 541-543).

Bolzen zum Öffnen der Kühlmittelzufuhr
 Pin for opening the cooling supply

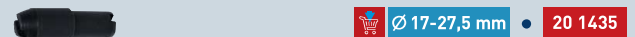

Schnittdaten
 Cutting data

Film
 Movie



1493

Pulverstahl + DURABLUE-beschichteter Spiralbohrer mit Innenkühlung, Nutzlänge 50 mm, Weldonschaft
 Powder steel + DURABLUE-coated twist drill with internal cooling supply, drill depth 50 mm | 2", Weldon shank

DRILL-LINE 750 PRO **20 1465**

ANWENDUNG · APPLICATION

Stahl Steel	Edelstahl Stainless	Grauguss Grey cast iron	Alu Alu	Kupfer, Messing, Zinn Copper, brass, tin	Kunststoffe GFK/CFK Plastics GRP/CRP	Hastelloy, Inconel, Exotische Materialien Hastelloy, Inconel, exotic materials	Hardox 400 Hardox 400
< 1400 N	> 900 N		> 10% Si				

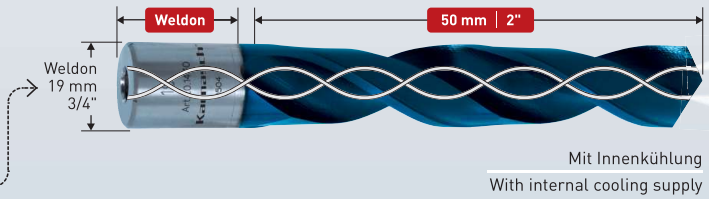

Mit Innenkühlung
With internal cooling supply

Wird ohne Bolzen zum Öffnen der Kühlmittelzufuhr geliefert (wenn benötigt siehe Zubehör).
 Will be delivered without pin for opening the cooling supply (see accessories if required).

Art.	Ø mm	Ø Zoll Inch	Art.	Ø mm	Ø Zoll Inch	Art.	Ø mm	Ø Zoll Inch
20 1465 014	14	35/64"	20 1465 020	20	25/32"	20 1465 026	26	1.1/32"
20 1465 015	15	19/32"	20 1465 021	21	53/64"	20 1465 027	27	1.1/16"
20 1465 016	16	5/8"	20 1465 022	22	55/64"	20 1465 028	% 28	1.7/64"
20 1465 017	17	43/64"	20 1465 023	23	29/32"	20 1465 030	30	1.3/16"
20 1465 018	18	45/64"	20 1465 024	24	15/16"	20 1465 032	32	1.17/64"
20 1465 019	19	3/4"	20 1465 025	25	63/64"			

Achtung: Die Zollabmessungen entsprechen nicht exakt den mm Durchmesser.

Attention: The inch sizes do not correspond exactly to the mm diameters.

% Sonderpreis / Sale Artikel. Lieferbar solange Vorrat.
 Special price / sale article. While stocks last.

ZUBEHÖR · ACCESSORY

Der Bolzen ist nur notwendig, wenn Aufnahmehalter mit Innenkühlung verwendet werden (Siehe Seite 541-543).

The pin is only necessary if you use tool holders with internal cooling supply (see page 541-543).

Bolzen zum Öffnen der Kühlmittelzufuhr
Pin for opening the cooling supply



Ø 14-32 mm • 20 1435

EIGENSCHAFTEN · PROPERTIES

Für Art. 20 1430 Seite 446 sowie für Art. 20 1465 · For Art. 20 1430 page 446 and for Art. 20 1465



Gefertigt aus ASP Pulverstahl zum Bohren auch schwierigster Materialien wie Eisenbahnschienen, Edelstähle, exotische Legierungen. Immer dort einsetzbar wo höchste Verschleißfestigkeit und Standzeit benötigt wird.

Made of ASP powder steel for drilling of difficult materials like railway tracks, stainless steels, exotic alloys. Applicable wherever a high wear resistance and lifetime are required.

Karnasch Spiralbohrer werden mit einer Hochleistungsgeometrie gefertigt für: Sofortiges Selbstzentrieren, leichteres Zerspanen, höchste Standzeiten.

Karnasch twist drills are produced in a heavy-duty geometry for immediate self-centering, easy cutting, highest lifetimes.

Unsere hochwertigsten Spiralbohrer erhalten die einzigartige und patentierte DURABLUE-Beschichtung. Extreme Oberflächenhärte- und -glätte ergeben extreme Standzeiten auch unter nicht optimalen Arbeitsbedingungen wie „Über Kopf arbeiten“, Trockenbohrungen, u.s.w.

Our first-class twist drills are equipped with the unique and patented DURABLUE-coating. Extreme surface hardness and sleekness yield extreme lifetimes even under non-optimum conditions like "overhead work", dry drilling, etc.

Schnittdaten
Cutting data



1493

Film
Movie



447

- 1
- 2
- 3
- 4
- 5
- 6
- 7
- 8
- 9
- 10 **Index**



20 1710

DRILL-LINE 30



HSS-XE Spiralbohrer, Nutzlänge 30 mm, Weldonschaft
HSS-XE twist drill, drill depth 30 mm | 1", Weldon shank

ANWENDUNG • APPLICATION

Stahl	Edelstahl	Grauguss	Alu	Kupfer, Messing, Zinn	Kunststoffe GFK/CFK
Steel	Stainless	Grey cast iron	Alu	Copper, brass, tin	Plastics GRP/CRP
< 900 N	< 900 N		< 10% Si		

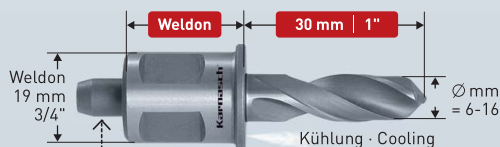

Ø 6-16 mm wird mit Bolzen zum Öffnen der Kühlmittelzufuhr geliefert.
Ø 6-16 mm will be delivered with pin for opening the cooling supply.

Art.	Ø mm	Ø Zoll	Art.	Ø mm	Ø Zoll
20 1710 006	6	15/64"	20 1710 012	12	15/32"
20 1710 008	8	5/16"	20 1710 013	13	33/64"
20 1710 0095	9,5	25/64"	20 1710 0135	13,5	17/32"
20 1710 0098	9,8	25/64"	20 1710 014	14	35/64"
20 1710 010	10	25/64"	20 1710 015	15	19/32"
20 1710 011	11	7/16"	20 1710 016	16	5/8"

Achtung: Die Zollabmessungen entsprechen nicht exakt den mm Durchmessern.
Attention: The inch sizes do not correspond exactly to the mm diameters.

20 1710

DRILL-LINE 40



HSS-XE Spiralbohrer mit Innenkühlung, Nutzlänge 40 mm, Weldonschaft
HSS-XE Spiralbohrer twist drill with internal cooling supply, drill depth 40 mm | 1", Weldon shank

ANWENDUNG • APPLICATION

Stahl	Edelstahl	Grauguss	Alu	Kupfer, Messing, Zinn	Kunststoffe GFK/CFK
Steel	Stainless	Grey cast iron	Alu	Copper, brass, tin	Plastics GRP/CRP
< 900 N	< 900 N		< 10% Si		

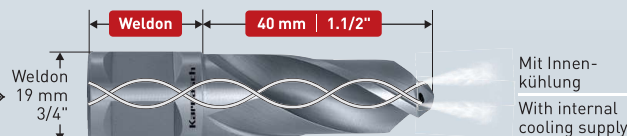

Ø 17-27,5 mm wird ohne Bolzen zum Öffnen der Kühlmittelzufuhr geliefert (wenn benötigt siehe Zubehör).
Ø 17-27,5 mm will be delivered without pin for opening the cooling supply (see accessories if required).

Art.	Ø mm	Ø Zoll	Art.	Ø mm	Ø Zoll
20 1710 017	17	43/64"	20 1710 024	24	15/16"
20 1710 019	19	3/4"	20 1710 0275	27,5	1.5/64"
20 1710 020	20	25/32"			
20 1710 021	21	53/64"			
20 1710 022	22	55/64"			
20 1710 023	23	29/32"			

Ersatzartikel siehe Art. 20 1430 Seite 446 / Replacement article see Art. 20 1430 page 446

Achtung: Die Zollabmessungen entsprechen nicht exakt den mm Durchmessern.
Attention: The inch sizes do not correspond exactly to the mm diameters.

ZUBEHÖR • ACCESSORY

Der Bolzen ist nur notwendig, wenn Aufnahmehalter mit Innenkühlung verwendet werden (Siehe Seite 541-543).
The pin is only necessary if you use tool holders with internal cooling supply (see page 541-543).

Bolzen zum Öffnen der Kühlmittelzufuhr
Pin for opening the cooling supply



20 1435

EIGENSCHAFTEN • PROPERTIES



Gefertigt aus hochlegiertem HSS-XE Spezialstahl. Für extreme Härte an den Zahnsitzen (bis 68 HRC). Somit hohe Verschleißfestigkeit und Standzeit.

Karnasch Spiralbohrer werden mit einer Hochleistungsgeometrie gefertigt für: Sofortiges Selbstzentrieren, leichteres Zerspanen, höchste Standzeiten.

Made of high-alloyed HSS-XE special steel. For extreme hardness at the tip of the tooth (up to 68 HRC). Thus guaranteeing a high wear resistance and lifetime.

Karnasch twist drills are produced in a heavy-duty geometry for immediate self-centering, easy cutting, highest lifetimes.

Schnittdaten
Cutting data

Film
Movie



20 1830



20 1840

DRILL-LINE GOLD 50



Adapter Weldonschaft
Adapter Weldon shank

HSS-CO Cobalt + TiN beschichteter Spiralbohrer, Nutzlänge 50 mm
HSS-CO Cobalt + TiN coated twist drill, drill depth 50 mm | 2"

ANWENDUNG · APPLICATION

Stahl Steel	Edelstahl Stainless	Grauguss Grey cast iron	Alu Alu	Kupfer, Messing, Zinn Copper, brass, tin	Kunststoffe GFK/CFK Plastics GRP/CRP
< 1400 N	> 900 N		> 10% Si		



Adapter · Adapter	Schaft · Shank	Spiralbohrer · Twist drill	Bohrer · Drill	Für Gewinde · For thread Size
• 20 1830 002	↓ 2,5 mm		Ø 2,5 mm Ø 3/32"	• 20 1840 002 M 3
• 20 1830 004	↓ 3 mm		Ø 3,4 mm Ø 9/64"	• 20 1840 004 M 4
• 20 1830 010	↓ 4 mm		Ø 4,3 mm Ø 11/64"	• 20 1840 006 M 5
			Ø 4 mm Ø 5/32"	-
• 20 1830 020	↓ 5 mm		Ø 5 mm Ø 13/64"	• 20 1840 020 M 6
• 20 1830 030	↓ 6 mm		Ø 6 mm Ø 15/64"	-
			Ø 6,8 mm Ø 17/64"	• 20 1840 035 M 8
• 20 1830 040	↓ 7 mm		Ø 7 mm Ø 9/32"	-
• 20 1830 050	↓ 8 mm		Ø 8 mm Ø 5/16"	-
			Ø 8,5 mm Ø 21/64"	• 20 1840 055 M 10
• 20 1830 060	↓ 9 mm		Ø 9 mm Ø 23/64"	-
• 20 1830 070	↓ 10 mm		Ø 10 mm Ø 25/64"	-
			Ø 10,3 mm Ø 13/32"	• 20 1840 075 M 12
• 20 1830 080	↓ 11 mm		Ø 11 mm Ø 7/16"	-
• 20 1830 090	↓ 12 mm		Ø 12 mm Ø 15/32"	• 20 1840 090 M 14

Gewindebohrer Siehe Art. 20 1820 Seite 649 · **Achtung:** Die Zollabmessungen entsprechen nicht exakt den mm Durchmessern.
Taps see Art. 20 1820 page 649 · **Attention:** The inch sizes do not correspond exactly to the mm diameters.



EIGENSCHAFTEN · PROPERTIES

Cobaltstahl + TiN-Beschichtung für eine nochmalige wesentliche Erhöhung der Standzeit auch bei Trockenbearbeitung (ohne/wenig Kühlung)

Cobalt steel + TiN-coating for a further substantial increase in service life also when machining dry (no/little cooling)

Schnelle, preiswerte und präzise Bohrungen mit Karnasch Hochleistungsspiralbohrer + Spiralbohradapter Weldon

Fast, inexpensive and accurate holes with Karnasch high-performance twist drills + twist drill adaptor Weldon

Schnittdaten
Cutting data



KERNBOHRER MIT NITTO / UNIVERSALSCHAFT

ANNULAR CUTTERS WITH NITTO / UNIVERSAL SHANK

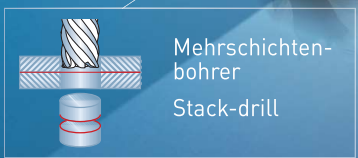

Passende Kernbohrmaschinen von Nitto:
Matching machines made by Nitto:

NITTO KOHKI "ONE TOUCH" TYPE:
WOJ 3200 · AO 5575 · WA 3500 · WA 5000 · QA 4000 · QA 6500





Passend auch für alle Maschinen mit Weldonenschaft 19 mm (siehe Seite 376).
Hierbei ist darauf zu achten, dass nur **eine** Spannfläche vorhanden ist.

Also matching all machines with Weldon shank 19 mm (3/4") (see page 376).
Observe that there is only **one** clamping face.

NITTO / UNIVERSALSCHAFT

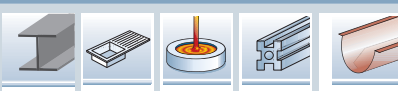
- 1
- 2
- 3
- 4
- 5
- 6
- 7
- 8
- 9
- 10

Übersicht Kernbohrer Nitto / Universalschaft Overview annular cutters Nitto / Universal shank

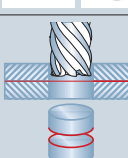
TYPE	Ø	Anwendung · Application	Beschreibung · Specification																						
HARD-LINE	Ø 12-65 mm Ø 1/2-2.1/16"	<p>Kernbohrer Hartmetall-bestückt Die leistungsstärksten Kernbohrer in unserem Sortiment. Exzellent für alle Stähle bis 1400 N Festigkeit sowie für alle Edelstähle.</p> <p>Annular cutters carbide-tipped The most powerful annular cutters in our range. Excellent for all steels up to a strength of 1400 N and for all stainless steels.</p>	 <table border="1"> <tr> <td>Stahl</td> <td>Edelstahl</td> <td>Grauguss</td> <td>Alu</td> <td>Kupfer, Messing, Zinn</td> </tr> <tr> <td>Steel</td> <td>Stainless</td> <td>Grey cast iron</td> <td>Alu</td> <td>Copper, brass, tin</td> </tr> <tr> <td>< 1400 N</td> <td>> 900 N</td> <td>✓</td> <td>> 10% Si</td> <td>✓</td> </tr> </table>	Stahl	Edelstahl	Grauguss	Alu	Kupfer, Messing, Zinn	Steel	Stainless	Grey cast iron	Alu	Copper, brass, tin	< 1400 N	> 900 N	✓	> 10% Si	✓	452-467						
Stahl	Edelstahl	Grauguss	Alu	Kupfer, Messing, Zinn																					
Steel	Stainless	Grey cast iron	Alu	Copper, brass, tin																					
< 1400 N	> 900 N	✓	> 10% Si	✓																					
BLUE-DRILL LINE	Ø 12-60 mm Ø 7/16-2.1/16"	<p>Kernbohrer aus HSS-XE Spezialstahl + DURABLU- Beschichtung. Der am meisten verwendete beschichtete Kernbohrer für alle Stähle bis 1100 N Festigkeit sowie für alle Edelstähle.</p> <p>Annular cutters made of HSS-XE special steel + DURABLU-coating. The most-often used coated annular cutter for all steels up to a strength of 1100 N and for all stainless steels.</p>	 <table border="1"> <tr> <td>Stahl</td> <td>Edelstahl</td> <td>Grauguss</td> <td>Alu</td> <td>Kupfer, Messing, Zinn</td> </tr> <tr> <td>Steel</td> <td>Stainless</td> <td>Grey cast iron</td> <td>Alu</td> <td>Copper, brass, tin</td> </tr> <tr> <td>< 1400 N</td> <td>> 900 N</td> <td>✓</td> <td>> 10% Si</td> <td>✓</td> </tr> </table>  <table border="1"> <tr> <td>Hardox 400</td> <td>Hardox 450</td> </tr> <tr> <td>Hardox 400</td> <td>Hardox 450</td> </tr> <tr> <td>✓</td> <td>✓</td> </tr> </table>	Stahl	Edelstahl	Grauguss	Alu	Kupfer, Messing, Zinn	Steel	Stainless	Grey cast iron	Alu	Copper, brass, tin	< 1400 N	> 900 N	✓	> 10% Si	✓	Hardox 400	Hardox 450	Hardox 400	Hardox 450	✓	✓	468-483
Stahl	Edelstahl	Grauguss	Alu	Kupfer, Messing, Zinn																					
Steel	Stainless	Grey cast iron	Alu	Copper, brass, tin																					
< 1400 N	> 900 N	✓	> 10% Si	✓																					
Hardox 400	Hardox 450																								
Hardox 400	Hardox 450																								
✓	✓																								
GOLD-DRILL LINE	Ø 12-60 mm Ø 7/16-2.1/16"	<p>Kernbohrer aus HSS-XE Spezialstahl + GOLD-TECH-Behandlung. Der am meisten verwendete nicht beschichtete Kernbohrer für alle Stähle bis 900 N Festigkeit. Auch noch für Edelstahl geeignet.</p> <p>Annular cutters made of HSS-XE special steel + GOLD-TECH treatment. The most-often used uncoated annular cutter for all steels up to a strength of 900 N. Still suitable for stainless steels.</p>	 <table border="1"> <tr> <td>Stahl</td> <td>Edelstahl</td> <td>Alu</td> <td>Kupfer, Messing, Zinn</td> </tr> <tr> <td>Steel</td> <td>Stainless</td> <td>Alu</td> <td>Copper, brass, tin</td> </tr> <tr> <td>< 1400 N</td> <td>> 900 N</td> <td>> 10% Si</td> <td>✓</td> </tr> </table>	Stahl	Edelstahl	Alu	Kupfer, Messing, Zinn	Steel	Stainless	Alu	Copper, brass, tin	< 1400 N	> 900 N	> 10% Si	✓	484-499									
Stahl	Edelstahl	Alu	Kupfer, Messing, Zinn																						
Steel	Stainless	Alu	Copper, brass, tin																						
< 1400 N	> 900 N	> 10% Si	✓																						
GOLD-DRILL LINE SANDWICH	Ø 14-32 mm Ø 9/16-1.1/16"	<p>Kernbohrer aus HSS-XE Spezialstahl + GOLD-TECH-Behandlung. Der am meisten verwendete nicht beschichtete Kernbohrer für alle Stähle bis 900 N Festigkeit. Auch noch für Edelstahl geeignet.</p> <p>Annular cutters made of HSS-XE special steel + GOLD-TECH treatment. The most-often used uncoated annular cutter for all steels up to a strength of 900 N. Still suitable for stainless steels.</p>	 <p>Mehrschichtenbohrer. Spezialgeometrie zum Bohren übereinanderliegender Metallplatten bis 1100 N (Sandwich)</p> <p>Multi layer drill. For stack drilling (sandwich) in steel up to 1100 N</p>	502-505																					



HARTMETALL-BESTÜCKTE KERNBOHRER CARBIDE-TIPPED ANNULAR CUTTERS



HARD-LINE

Der beste Kernbohrer ist grundsätzlich Hartmetall-bestückt.

Nur diese Bohrer bieten das optimale Preis-Leistungs-Verhältnis für nahezu alle Materialien. Neben der höchsten Standzeit in allen Stählen bieten nur Hartmetall-bestückte Kernbohrer:

- Bohren in Stähle bis 40 Rockwell (HRC)
- Bohren in alle Edelstähle
- Bohren in schwierigste Legierungen (Hardox/Inconel/Titan)
- Bohren hervorragend auch in weiche Werkstoffe wie Alu, Kupfer, Messing u.ä.

Mit Durchmessern von 12-65 mm in Schnitttiefen von 40, 55, 80, 110 mm steht Ihnen weltweit das umfangreichste Lagerprogramm zur Verfügung.

The fact is: The best annular cutters are carbide tipped.

Only these drills offer the best value for money for almost all materials. Only carbide tipped annular cutters provide maximum cutting capacity in all kinds of steels:

- Drilling in hardened steel up to 40 Rockwell (HRC)
- Drilling in all sorts of stainless steel
- Drilling in most difficult alloys (Hardox/Inconel/Titan)
- Drilling also excellent in all non-ferrous metals such as alu, copper, brass

Available in diameter 12-65 mm. Available in drill depths 40 mm, 55 mm, 80 mm and 110 mm. Simply the world's largest stock range of carbide tipped annular cutter.

EIGENSCHAFTEN · PROPERTIES



Karnasch Hartmetall-bestückte Kernbohrer (HARD-LINE) werden mit konischer Spirale gefertigt für: Sauberen Spanfluss und höchste Zerspanleistung auch bei schwierigen Materialien.

Karnasch carbide tipped annular cutters (HARD-LINE) are made with a conical helix for: clean chip flow and highest cutting ability even with difficult materials.



Karnasch Hartmetall-bestückte Kernbohrer (HARD-LINE) werden ausschließlich mit Sandvik Hartmetallzähnen bestückt. Wir meinen: Nur das beste Hartmetall ist gut genug für Karnasch Kernbohrer.

Karnasch carbide tipped annular cutters (HARD-LINE) are exclusively equipped with Sandvik carbide teeth. Our opinion is: Only the best carbide is good enough for Karnasch annular cutters.



Karnasch Hartmetall-bestückte Kernbohrer (HARD-LINE) sind in einer aufwendigen Vor-Mittel-Nachsneider-Geometrie gefertigt. Dies ergibt: ratterfreies, ruhiges und leichtes Zerspanen mit höchsten Standzeiten.

Karnasch carbide tipped annular cutters (HARD-LINE) are made in an elaborate pre-/intermediate-/after-cutting geometry. This results in: clatter-free, silent and easy cutting with highest lifetimes.

ANWENDUNG · APPLICATION

Stahl	Edelstahl	Alu	Kupfer, Messing, Zinn	Kunststoffe GFK/CFK	Grauguss	Graphit	Hastelloy, Inconel, Nimonic, Exotische Materialien	Schienen
Steel	Stainless	Alu	Copper, brass, tin	Plastics GRP/CRP	Grey cast iron	Graphite	Hastelloy, Inconel, Nimonic, exotic materials	Rails
< 1400 N	> 900 N	> 10% Si						
✓	✓	✓	✓	✓	✓	✓	✓	✓

✓ OPTIMAL · OPTIMAL

✓ GUT · GOOD

✓ MÖGLICH · POSSIBLE

HARTMETALL-BESTÜCKTE KERNBOHRER CARBIDE-TIPPED ANNULAR CUTTERS

Schnitttiefe · Drill depths	Ø mm	Ø Zoll / Inch	Art. / Type	
 Nitto / Universal 40 mm 1.1/2"	12-65	15/32-2.9/16"	20 1315N HARD-LINE / 40	454
 Nitto / Universal 55 mm 2"	12-60	15/32-2.23/64"	20 1316N HARD-LINE / 55	456
 Nitto / Universal 80 mm 3"	14-50	35/64-1.31/32"	20 1650N HARD-LINE / 80	458
 Nitto / Universal 110 mm 4"	14-50	35/64-1.31/32"	20 1660N HARD-LINE / 110	460
 Nitto / Universal 40 mm 1.1/2"	-	1/2-2.1/16"	20 1630 HARD-LINE / 40 ZOLL / INCH	462
 Nitto / Universal 55 mm 2"	-	1/2-2.1/16"	20 1640 HARD-LINE / 55 ZOLL / INCH	464
 Nitto / Universal 80 mm 3"	-	11/16-2.1/16"	20 1670 HARD-LINE / 80 ZOLL / INCH	466

ZUBEHÖR · SETS · DISPLAYS · ERSATZTEILE / ACCESSORIES · SETS · DISPLAYS · SPARE PARTS

Aufnahmehalter mit Morsekonus 2 / 3 / 4 / 5 und Reduzierhülsen  541-543
Tool holders with morse taper 2 / 3 / 4 / 5 and reduction sleeves



Kühlmittel-Druckflaschen  548
Coolant pressure bottles



Kegelsenker mit Weldonchaft  544/545
Countersinks with Weldon shank

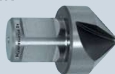

Magnetstab zur Entfernung der Bohrspäne  549
Magnetic stick for chip removal



Spiralbohradapter Weldon + Spiralbohrer Ø 2,5-12 mm  648
Twist drill adaptors Weldon + twist drills Ø 2,5-12 mm



Sets · Displays  553-582
Sets · Displays



Gewintheadapter Weldon + Gewindebohrer M 3 - M 30  649-650
Tapping adapter Weldon + taps M 3 - M 30



Adapter + passende Bohrfutter  548
Adapters + suitable drill chucks

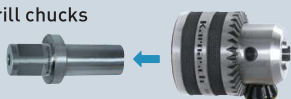

Ersatzteile  550-552
Spare parts



20 1315N

HARD-LINE 40

Hartmetall-bestückter Kernbohrer, Nitto/Universalschaft, Nutzlänge 40 mm
Carbide-tipped annular cutter, Nitto/Universal shank, drill depth 40 mm | 1.1/2"



ANWENDUNG • APPLICATION

Stahl	Edelstahl	Grauguss	Alu	Kupfer, Messing, Zinn	Kunststoffe GFK/CFK	Hastelloy, Inconel, Exotische Materialien
Steel	Stainless	Grey cast iron	Alu	Copper, brass, tin	Plastics GRP/CRP	Hastelloy, Inconel, exotic materials
< 1400 N	> 900 N		> 10% Si			

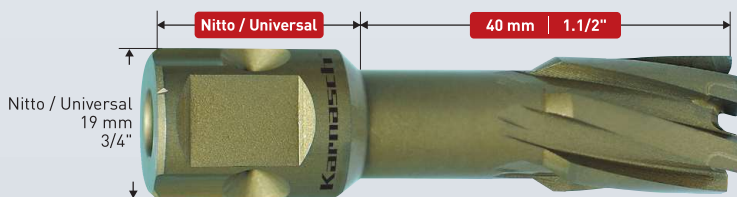

⚡ Sonderpreis / Sale Artikel. Lieferbar solange Vorrat.
Special price / sale article. While stocks last.

Art.	Ø mm	Ø Zoll Inch	Art.	Ø mm	Ø Zoll Inch	Art.	Ø mm	Ø Zoll Inch	Art.	Ø mm	Ø Zoll Inch
20 1315N 012	• 12	15/32"	20 1315N 026	• 26	1.1/32"	20 1315N 040	• 40	1.37/64"	20 1315N 054	⚡ 54	2.1/8"
20 1315N 013	• 13	33/64"	20 1315N 027	• 27	1.1/16"	20 1315N 041	• 41	1.39/64"	20 1315N 055	• 55	2.11/64"
20 1315N 014	• 14	35/64"	20 1315N 028	• 28	1.7/64"	20 1315N 042	• 42	1.21/32"	20 1315N 056	• 56	2.13/64"
20 1315N 015	• 15	19/32"	20 1315N 029	• 29	1.9/64"	20 1315N 043	⚡ 43	1.11/16"	20 1315N 057	• 57	2.1/4"
20 1315N 016	• 16	5/8"	20 1315N 030	• 30	1.3/16"	20 1315N 044	• 44	1.47/64"	20 1315N 058	⚡ 58	2.9/32"
20 1315N 017	• 17	43/64"	20 1315N 031	• 31	1.7/32"	20 1315N 045	• 45	1.49/64"	20 1315N 059	• 59	2.21/64"
20 1315N 018	• 18	45/64"	20 1315N 032	• 32	1.17/64"	20 1315N 046	• 46	1.13/16"	20 1315N 060	• 60	2.23/64"
20 1315N 019	• 19	3/4"	20 1315N 033	• 33	1.19/64"	20 1315N 047	⚡ 47	1.27/32"	20 1315N 061	• 61	2.13/32"
20 1315N 020	• 20	25/32"	20 1315N 034	• 34	1.11/32"	20 1315N 048	• 48	1.57/64"	20 1315N 062	• 62	2.7/16"
20 1315N 021	• 21	53/64"	20 1315N 035	• 35	1.3/8"	20 1315N 049	• 49	1.59/64"	20 1315N 063	• 63	2.31/64"
20 1315N 022	• 22	55/64"	20 1315N 036	• 36	1.27/64"	20 1315N 050	• 50	1.31/32"	20 1315N 064	• 64	2.33/64"
20 1315N 023	• 23	29/32"	20 1315N 037	• 37	1.29/64"	20 1315N 051	• 51	2.1/64"	20 1315N 065	• 65	2.9/16"
20 1315N 024	• 24	15/16"	20 1315N 038	• 38	1.1/2"	20 1315N 052	• 52	2.3/64"			
20 1315N 025	• 25	63/64"	20 1315N 039	• 39	1.17/32"	20 1315N 053	⚡ 53	2.3/32"			

Größere Ø bis 100 mm siehe Art. 20 1130A + Adapter Seite 595 / 597.
Achtung: Die Zollabmessungen entsprechen nicht exakt den mm Durchmessern.
Larger Ø up to 100 mm see Art. 20 1130A + adapter page 595 / 597.
Attention: The inch sizes do not correspond exactly to the mm diameters.

20 1315N

HARD-LINE 40

ZUBEHÖR • ACCESSORIES

AUSWERFERSTIFTE • EJECTOR PINS

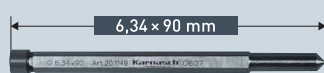

⚡ Ø 12-17 mm • 20 1149

Packnorm 2 Stk. • Packaging unit 2 pcs.



⚡ Ø 18-65 mm • 20 1151

Packnorm 2 Stk. • Packaging unit 2 pcs.

20 1315N

HARD-LINE 40

SETS / DISPLAYS Seite / Page 568

Wir bieten eine große Auswahl an Sets / Displays – Inhaltsvorschläge 20 1315N HARD-LINE40 – siehe Seite 568. Anderer Inhalt auf Wunsch möglich, durch individuell bestückbare Sets / Displays.
We offer a large selection of sets / displays – recommended content 20 1315N HARD-LINE40 – see page 568. Other content possible by individually equipped sets / displays.



Schnittdaten
Cutting data

Film
Movie



1487



- 1
- 2
- 3
- 4
- 5
- 6
- 7
- 8
- 9
- 10

Zubehör für Hartmetall-bestückte Kernbohrer, Nitto/Universalschaft, Nutzlänge 40 mm
 Accessories for carbide-tipped annular cutter, Nitto/Universal shank, drill depth 40 mm | 1.1/2"

HARD-LINE 40

20 1315N

ADAPTER + PASSENDE AUSWERFERSTIFTE
ADAPTER + SUITABLE EJECTOR PINS

 **Ø 12-17 mm • 20 1263**
 FEIN Quick-In 18 mm
 Weldon + Nitto/Universal 19 mm 3/4"
6,34 × 116 mm
20 1318
 Packnorm 2 Stk. · Packaging unit 2 pcs.

 **Ø 18-60 mm • 20 1161**
 FEIN Quick-In 18 mm
 Weldon + Nitto/Universal 19 mm 3/4"
7,98 × 118 mm
20 1272
 Packnorm 2 Stk. · Packaging unit 2 pcs.

 **21 0048**
 Weldon 32 mm 1.1/4"
 Weldon + Nitto/Universal 19 mm 3/4"
6,34 × 90 mm
Ø 12-17 mm • 20 1149
 Packnorm 2 Stk. · Packaging unit 2 pcs.
7,98 × 90 mm
Ø 18-65 mm • 20 1151
 Packnorm 2 Stk. · Packaging unit 2 pcs.

Ersatz-Innensechskantschrauben für alle Adapter siehe Seite 550
 Spare allen screws for all adapters see page 550

Weiteres Zubehör siehe Übersichtsseite 453
 Further accessories see overview page 453

VERLÄNGERUNGEN + PASSENDE AUSWERFERSTIFTE
EXTENSIONS + SUITABLE EJECTOR PINS

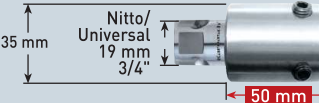
 **Ø 12-17 mm • 20 1406**
 Nitto/Universal 19 mm 3/4"
 Weldon + Nitto/Universal 19 mm 3/4"
50 mm
7,98 × 6,34 × 5,30 × 140 mm
20 1390
 Packnorm 2 Stk. · Packaging unit 2 pcs.

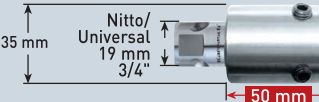
 **Ø 18-65 mm • 20 1406**
 Nitto/Universal 19 mm 3/4"
 Weldon + Nitto/Universal 19 mm 3/4"
50 mm
7,98 × 135 mm
20 1393
 Packnorm 2 Stk. · Packaging unit 2 pcs.

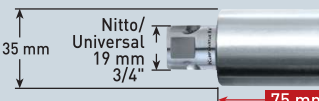
 **Ø 12-17 mm • 20 1407**
 Nitto/Universal 19 mm 3/4"
 Weldon + Nitto/Universal 19 mm 3/4"
75 mm
7,98 × 6,34 × 5,30 × 165 mm
20 1405
 Packnorm 2 Stk. · Packaging unit 2 pcs.

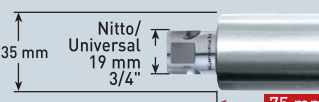
 **Ø 18-65 mm • 20 1407**
 Nitto/Universal 19 mm 3/4"
 Weldon + Nitto/Universal 19 mm 3/4"
75 mm
7,98 × 167 mm
20 1408
 Packnorm 2 Stk. · Packaging unit 2 pcs.

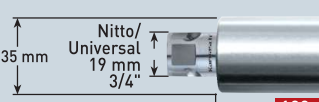
 **Ø 12-17 mm • 20 1409**
 Nitto/Universal 19 mm 3/4"
 Weldon + Nitto/Universal 19 mm 3/4"
100 mm
7,98 × 6,34 × 5,30 × 190 mm
20 1420
 Packnorm 2 Stk. · Packaging unit 2 pcs.

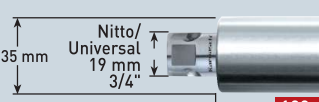
 **Ø 18-65 mm • 20 1409**
 Nitto/Universal 19 mm 3/4"
 Weldon + Nitto/Universal 19 mm 3/4"
100 mm
7,98 × 190 mm
20 1423
 Packnorm 2 Stk. · Packaging unit 2 pcs.

Ersatz-Innensechskantschrauben für alle Verlängerungen siehe Seite 550
 Spare allen screws for all extensions see page 550

Weiteres Zubehör siehe Übersichtsseite 453
 Further accessories see overview page 453

- 1 
- 2 
- 3 
- 4 
- 5 
- 6 
- 7 
- 8 
- 9 
- 10 

20 1316N

HARD-LINE 55

Hartmetall-bestückter Kernbohrer, Nitto/Universalschaft, Nutzlänge 55 mm
Carbide-tipped annular cutter, Nitto/Universal shank, drill depth 55 mm | 2"



ANWENDUNG • APPLICATION

Stahl	Edelstahl	Grauguss	Alu	Kupfer, Messing, Zinn	Kunststoffe GFK/CFK	Hastelloy, Inconel, Exotische Materialien
Steel	Stainless	Grey cast iron	Alu	Copper, brass, tin	Plastics GRP/CRP	Hastelloy, Inconel, exotic materials
< 1400 N	> 900 N		> 10% Si			

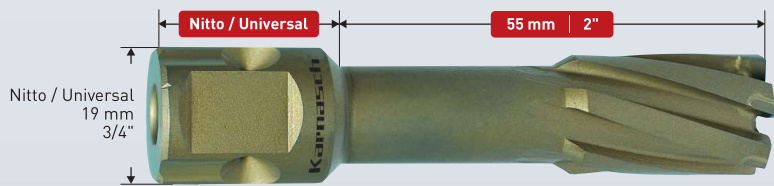

☞ Sonderpreis / Sale Artikel. Lieferbar solange Vorrat.
Special price / sale article. While stocks last.

Art.	Ø mm	Ø Zoll	Art.	Ø mm	Ø Zoll	Art.	Ø mm	Ø Zoll	Art.	Ø mm	Ø Zoll
20 1316N 012	12	15/32"	20 1316N 023	23	29/32"	20 1316N 034	34	1.11/32"	20 1316N 048	48	1.57/64"
20 1316N 013	13	33/64"	20 1316N 0235	23,5	59/64"	20 1316N 035	35	1.3/8"	20 1316N 049	49	1.59/64"
20 1316N 014	14	35/64"	20 1316N 024	24	15/16"	20 1316N 036	36	1.27/64"	20 1316N 050	50	1.31/32"
20 1316N 015	15	19/32"	20 1316N 0245	24,5	31/32"	20 1316N 037	37	1.29/64"	20 1316N 051	51	2.1/64"
20 1316N 016	16	5/8"	20 1316N 025	25	63/64"	20 1316N 038	38	1.1/2"	20 1316N 052	52	2.3/64"
20 1316N 017	17	43/64"	20 1316N 026	26	1.1/32"	20 1316N 039	39	1.17/32"	20 1316N 053	53	2.3/32"
20 1316N 0175	17,5	11/16"	20 1316N 0265	26,5	1.3/64"	20 1316N 040	40	1.37/64"	20 1316N 054	54	2.1/8"
20 1316N 018	18	45/64"	20 1316N 027	27	1.1/16"	20 1316N 041	41	1.39/64"	20 1316N 055	55	2.11/64"
20 1316N 019	19	3/4"	20 1316N 028	28	1.7/64"	20 1316N 042	42	1.21/32"	20 1316N 056	56	2.13/64"
20 1316N 020	20	25/32"	20 1316N 029	29	1.9/64"	20 1316N 043	43	1.11/16"	20 1316N 057	57	2.1/4"
20 1316N 021	21	53/64"	20 1316N 030	30	1.3/16"	20 1316N 044	44	1.47/64"	20 1316N 058	58	2.9/32"
20 1316N 0215	21,5	27/32"	20 1316N 031	31	1.7/32"	20 1316N 045	45	1.49/64"	20 1316N 059	59	2.21/64"
20 1316N 022	22	55/64"	20 1316N 032	32	1.17/64"	20 1316N 046	46	1.13/16"	20 1316N 060	60	2.23/64"
20 1316N 0225	22,5	57/64"	20 1316N 033	33	1.19/64"	20 1316N 047	47	1.27/32"			

Größere Ø bis 100 mm siehe Art. 20 1141A + Adapter Seite 599 / 601
Achtung: Die Zollabmessungen entsprechen nicht exakt den mm Durchmessern.
Larger Ø up to 100 mm see Art. 20 1141A + adapter page 599 / 601
Attention: The inch sizes do not correspond exactly to the mm diameters.

20 1316N

HARD-LINE 55

ZUBEHÖR • ACCESSORIES

AUSWERFERSTIFTE • EJECTOR PINS



Packnorm 2 Stk. · Packaging unit 2 pcs.

☞ Ø 12-17,5 mm • 20 1271

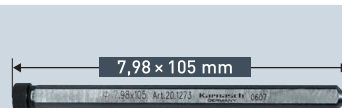

Packnorm 2 Stk. · Packaging unit 2 pcs.

☞ Ø 18-60 mm • 20 1273

20 1316N

HARD-LINE 55

SETS / DISPLAYS Seite / Page 569

Wir bieten eine große Auswahl an Sets / Displays – Inhaltsvorschläge 20 1316N HARD-LINE55 – siehe Seite 569. Anderer Inhalt auf Wunsch möglich, durch individuell bestückbare Sets / Displays.
We offer a large selection of sets / displays – recommended content 20 1316N HARD-LINE55 – see page 569. Other content possible by individually equipped sets / displays.



Schnittdaten
Cutting data

Film
Movie



1487

Zubehör für Hartmetall-bestückte Kernbohrer, Nitto/Universalschaft, Nutzlänge 55 mm
 Accessories for carbide-tipped annular cutter, Nitto/Universal shank, drill depth 55 mm | 2"

HARD-LINE 55

20 1316N

**ADAPTER + PASSENDE AUSWERFERSTIFTE
 ADAPTER + SUITABLE EJECTOR PINS**

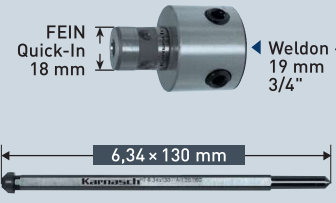
 **Ø 12-17,5 mm • 20 1263**
 FEIN Quick-In 18 mm
 Weldon + Nitto/Universal 19 mm 3/4"
6,34 × 130 mm
 Packnorm 2 Stk. · Packaging unit 2 pcs. **20 1160**

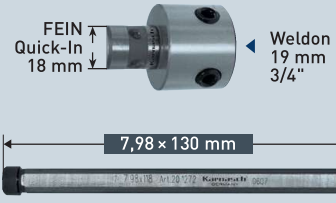
 **Ø 18-60 mm • 20 1161**
 FEIN Quick-In 18 mm
 Weldon + Nitto/Universal 19 mm 3/4"
7,98 × 130 mm
 Packnorm 2 Stk. · Packaging unit 2 pcs. **20 1439**

 **Ø 12-17,5 mm • 20 1271**
 Weldon 32 mm 1.1/4"
 Weldon + Nitto/Universal 19 mm 3/4"
6,34 × 102 mm
 Packnorm 2 Stk. · Packaging unit 2 pcs.
Ø 18-60 mm • 20 1273
7,98 × 105 mm
 Packnorm 2 Stk. · Packaging unit 2 pcs.

Ersatz-Innensechskantschrauben für alle Adapter siehe Seite 550
 Spare allen screws for all adapters see page 550

Weiteres Zubehör siehe Übersichtsseite 453
 Further accessories see overview page 453

**VERLÄNGERUNGEN + PASSENDE AUSWERFERSTIFTE
 EXTENSIONS + SUITABLE EJECTOR PINS**

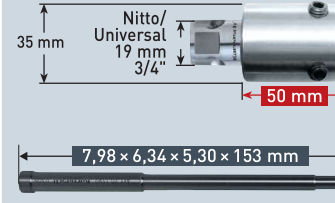
 **Ø 12-17,5 mm • 20 1406**
 Nitto/Universal 19 mm 3/4"
 Weldon + Nitto/Universal 19 mm 3/4"
50 mm
7,98 × 6,34 × 5,30 × 153 mm
 Packnorm 2 Stk. · Packaging unit 2 pcs. **20 1396**

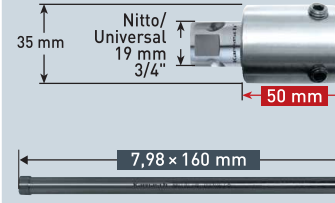
 **Ø 18-65 mm • 20 1406**
 Nitto/Universal 19 mm 3/4"
 Weldon + Nitto/Universal 19 mm 3/4"
50 mm
7,98 × 160 mm
 Packnorm 2 Stk. · Packaging unit 2 pcs. **20 1399**

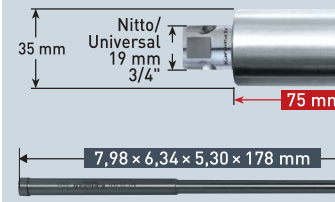
 **Ø 12-17,5 mm • 20 1407**
 Nitto/Universal 19 mm 3/4"
 Weldon + Nitto/Universal 19 mm 3/4"
75 mm
7,98 × 6,34 × 5,30 × 178 mm
 Packnorm 2 Stk. · Packaging unit 2 pcs. **20 1411**

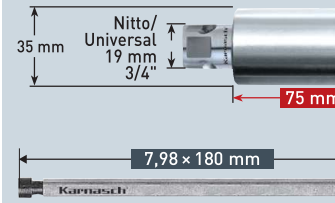
 **Ø 18-65 mm • 20 1407**
 Nitto/Universal 19 mm 3/4"
 Weldon + Nitto/Universal 19 mm 3/4"
75 mm
7,98 × 180 mm
 Packnorm 2 Stk. · Packaging unit 2 pcs. **20 1414**

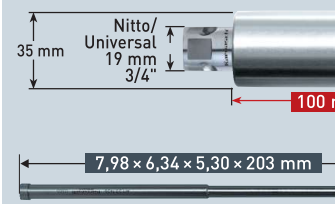
 **Ø 12-17,5 mm • 20 1409**
 Nitto/Universal 19 mm 3/4"
 Weldon + Nitto/Universal 19 mm 3/4"
100 mm
7,98 × 6,34 × 5,30 × 203 mm
 Packnorm 2 Stk. · Packaging unit 2 pcs. **20 1426**

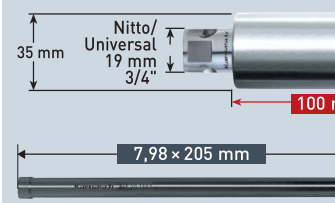
 **Ø 18-65 mm • 20 1409**
 Nitto/Universal 19 mm 3/4"
 Weldon + Nitto/Universal 19 mm 3/4"
100 mm
7,98 × 205 mm
 Packnorm 2 Stk. · Packaging unit 2 pcs. **20 1429**

Ersatz-Innensechskantschrauben für alle Verlängerungen siehe Seite 550
 Spare allen screws for all extensions see page 550

Weiteres Zubehör siehe Übersichtsseite 453
 Further accessories see overview page 453

- 1 
- 2 
- 3 
- 4 
- 5 
- 6 
- 7 
- 8 
- 9 
- 10 

20 1650N

HARD-LINE 80

Hartmetall-bestückter Kernbohrer, Nitto/Universalschaft, Nutzlänge 80 mm
Carbide-tipped annular cutter, Nitto/Universal shank, drill depth 80 mm | 3"



ANWENDUNG • APPLICATION

Stahl	Edelstahl	Grauguss	Alu	Kupfer, Messing, Zinn	Kunststoffe GFK/CFK	Hastelloy, Inconel, Exotische Materialien
Steel	Stainless	Grey cast iron	Alu	Copper, brass, tin	Plastics GRP/CRP	Hastelloy, Inconel, exotic materials
< 1400 N	> 900 N		> 10% Si			

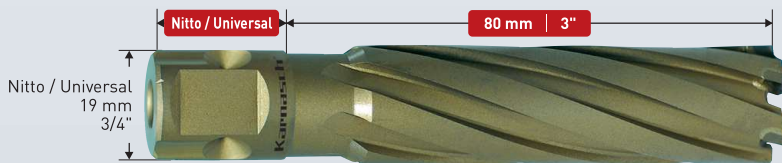

⚡ Sonderpreis / Sale Artikel. Lieferbar solange Vorrat.
Special price / sale article. While stocks last.

Art.	Ø mm	Ø Zoll Inch	Art.	Ø mm	Ø Zoll Inch	Art.	Ø mm	Ø Zoll Inch	Art.	Ø mm	Ø Zoll Inch
20 1650N 014	14	35/64"	20 1650N 024	24	15/16"	20 1650N 034	34	1.11/32"	20 1650N 044	44	1.47/64"
20 1650N 015	15	19/32"	20 1650N 025	25	63/64"	20 1650N 035	35	1.3/8"	20 1650N 045	45	1.49/64"
20 1650N 016	16	5/8"	20 1650N 026	26	1.1/32"	20 1650N 036	36	1.27/64"	20 1650N 046	46	1.13/16"
20 1650N 017	17	43/64"	20 1650N 027	27	1.1/16"	20 1650N 037	37	1.29/64"	20 1650N 047	47	1.27/32"
20 1650N 018	18	45/64"	20 1650N 028	28	1.7/64"	20 1650N 038	38	1.1/2"	20 1650N 048	48	1.57/64"
20 1650N 019	19	3/4"	20 1650N 029	29	1.9/64"	20 1650N 039	39	1.17/32"	20 1650N 049	49	1.59/64"
20 1650N 020	20	25/32"	20 1650N 030	30	1.3/16"	20 1650N 040	40	1.37/64"	20 1650N 050	50	1.31/32"
20 1650N 021	21	53/64"	20 1650N 031	31	1.7/32"	20 1650N 041	41	1.39/64"			
20 1650N 022	22	55/64"	20 1650N 032	32	1.17/64"	20 1650N 042	42	1.21/32"			
20 1650N 023	23	29/32"	20 1650N 033	33	1.19/64"	20 1650N 043	43	1.11/16"			

Größere Ø bis 60 mm mit Adapter siehe Art. 20 1650 Seite 386 ·
Achtung: Die Zollabmessungen entsprechen nicht exakt den mm Durchmessern.
Larger Ø up to 60 mm with adapter see Art. 20 1650 page 386 ·
Attention: The inch sizes do not correspond exactly to the mm diameters.

20 1650N

HARD-LINE 80

ZUBEHÖR • ACCESSORIES



AUSWERFERSTIFTE • EJECTOR PINS

Ø 14-17 mm • 20 1302

1-teilig / 1 piece

Packnorm 2 Stk. · Packaging unit 2 pcs.

Ø 18-50 mm • 20 1439

1-teilig / 1 piece

Packnorm 2 Stk. · Packaging unit 2 pcs.

Zusammen mit Aufnahmehalter 20 1842, 20 1291, 20 1843, 20 1845, 20 1846 (siehe Seite 542–543) kann dieser einteilige Auswerferstift verwendet werden. Es kann ohne Umstecken bis 110 mm Schnitttiefe in einem Arbeitsgang gebohrt werden. Robust und einfach.

It is possible to use this one-piece ejector pin in combination with tool holder article 20 1842, 20 1291, 20 1843, 20 1845, 20 1846 (see page 542–543). You can drill as deep as 110 mm in one working process without changing. Robust and easy.

AUSWERFERSTIFTE 2-TEILIG EJECTOR PINS 2-PIECE

Ø 18-50 mm • 20 1427

2-teilig / 2 piece

Packnorm 2 Stk. · Packaging unit 2 pcs.

ANWENDUNG AUSWERFERSTIFTE 2-TEILIG APPLICATION EJECTOR PINS 2-PIECE



Anwendung:
Teil 1 in den Schaft des Kernbohrers einführen. Teil 2 auf Teil 1 schieben. Bohren Sie bis ca. 50 mm Schnitttiefe. Danach Teil 2 entfernen und weiter bohren.

Application:
Insert piece 1 into the annular cutter shank. Push piece 2 onto part 1. Drill as deep as 50 mm cutting depth. Then remove piece 2 and continue drilling.

⚡ **Warum 2-teilige Auswerferstifte?** In der Regel haben Standard Morsekonus-Aufnahmehalter eine Schnitttiefenkapazität von 50 mm. Wenn **keine extra langen** Aufnahmehalter verwendet werden (wie auf Seite 542–543 Art. 20 1842, 20 1291, 20 1843, 20 1845, 20 1846), müssen bei Schnitttiefen über 50 mm 2-teilige Auswerferstifte verwendet werden.

⚡ **Why use 2-part ejector pins?** Usually, standard morse taper holders have a cutting depth capacity of 50 mm. If **no extra-long** holders are used (e.g. as on page 542–543 Art. 20 1842, 20 1291, 20 1843, 20 1845, 20 1846), you need for drill depths above 50 mm 2-part ejector pins.

Schnittdaten
Cutting data

Film
Movie



1487



- 1
- 2
- 3
- 4
- 5
- 6
- 7
- 8
- 9
- 10

Zubehör für Hartmetall-bestückte Kernbohrer, Nitto/Universalschaft, Nutzlänge 80 mm
 Accessories for carbide-tipped annular cutter, Nitto/Universal shank, drill depth 80 mm | 3"

HARD-LINE 80

20 1650N

ADAPTER + PASSENDE AUSWERFERSTIFTE · ADAPTER + SUITABLE EJECTOR PINS



• 20 0048



• Ø 18-50 mm • 20 1161

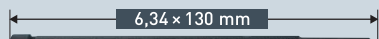

• Ø 14-17 mm • 20 1302

1-teilig / 1 piece

Packnorm 2 Stk. · Packaging unit 2 pcs.



• 20 1436

2-teilig / 2 piece

Packnorm 2 Stk. · Packaging unit 2 pcs.



• Ø 18-50 mm • 20 1439

1-teilig / 1 piece

Packnorm 2 Stk. · Packaging unit 2 pcs.



• Ø 18-50 mm • 20 1427

2-teilig / 2 piece

Packnorm 2 Stk. · Packaging unit 2 pcs.

Ersatz-Innensechskantschrauben für alle Adapter siehe Seite 550
 Spare allen screws for all adapters see page 550

ZUBEHÖR · SETS · DISPLAYS · ERSATZTEILE / ACCESSORIES · SETS · DISPLAYS · SPARE PARTS

Aufnahmehalter mit Morsekonus 2 / 3 / 4 / 5 und Reduzierhülsen 541-543
 Tool holders with morse taper 2 / 3 / 4 / 5 and reduction sleeves



Kühlmittel-Druckflaschen 548
 Coolant pressure bottles



Kegelsenker mit Weldonchaft 544/545
 Countersinks with Weldon shank

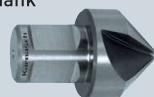

Magnetstab zur Entfernung der Bohrspäne 549
 Magnetic stick for chip removal



Spiralbohradapter Weldon + Spiralbohrer Ø 2,5-12 mm 648
 Twist drill adaptors Weldon + twist drills Ø 2,5-12 mm



Sets · Displays 553-582
 Sets · Displays

Gewindeadapter Weldon + Gewindebohrer M 3 - M 30 649-650
 Tapping adapter Weldon + taps M 3 - M 30



Vollhartmetall Gewindebohrer-Ausbohrer 652
 Solid carbide drills to remove jammed taps



Adapter + passende Bohrfutter 548
 Adapters + suitable drill chucks

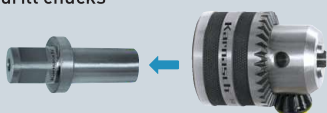

Ersatzteile 550-552
 Spare parts

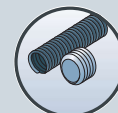

- 1
- 2
- 3
- 4
- 5
- 6
- 7
- 8
- 9
- 10

20 1660N

HARD-LINE / 110

Hartmetall-bestückter Kernbohrer, Nitto/Universalschaft, Nutzlänge 110 mm
Carbide-tipped annular cutter, Nitto/Universal shank, drill depth 110 mm | 4"



ANWENDUNG • APPLICATION

Stahl	Edelstahl	Grauguss	Alu	Kupfer, Messing, Zinn	Kunststoffe GFK/CFK	Hastelloy, Inconel, Exotische Materialien
Steel	Stainless	Grey cast iron	Alu	Copper, brass, tin	Plastics GRP/CRP	Hastelloy, Inconel, exotic materials
< 1400 N	> 900 N		> 10% Si			

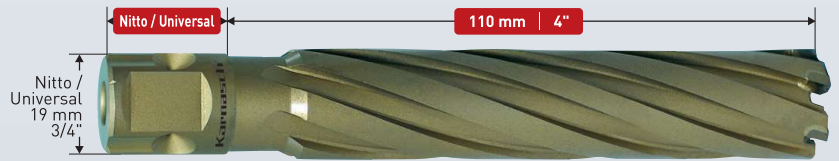

☞ Sonderpreis / Sale Artikel. Lieferbar solange Vorrat.
Special price / sale article. While stocks last.

Art.	Ø mm	Ø Zoll Inch	Art.	Ø mm	Ø Zoll Inch	Art.	Ø mm	Ø Zoll Inch	Art.	Ø mm	Ø Zoll Inch
20 1660N 014	14	35/64"	20 1660N 024	24	15/16"	20 1660N 034	34	1.11/32"	20 1660N 044	44	1.47/64"
20 1660N 015	15	19/32"	20 1660N 025	25	63/64"	20 1660N 035	35	1.3/8"	20 1660N 045	45	1.49/64"
20 1660N 016	16	5/8"	20 1660N 026	26	1.1/32"	20 1660N 036	36	1.27/64"	20 1660N 046	46	1.13/16"
20 1660N 017	17	43/64"	20 1660N 027	27	1.1/16"	20 1660N 037	37	1.29/64"	20 1660N 047	47	1.27/32"
20 1660N 018	18	45/64"	20 1660N 028	28	1.7/64"	20 1660N 038	38	1.1/2"	20 1660N 048	48	1.57/64"
20 1660N 019	19	3/4"	20 1660N 029	29	1.9/64"	20 1660N 039	39	1.17/32"	20 1660N 049	49	1.59/64"
20 1660N 020	20	25/32"	20 1660N 030	30	1.3/16"	20 1660N 040	40	1.37/64"	20 1660N 050	50	1.31/32"
20 1660N 021	21	53/64"	20 1660N 031	31	1.7/32"	20 1660N 041	41	1.39/64"			
20 1660N 022	22	55/64"	20 1660N 032	32	1.17/64"	20 1660N 042	42	1.21/32"			
20 1660N 023	23	29/32"	20 1660N 033	33	1.19/64"	20 1660N 043	43	1.11/16"			

Größere Ø bis 55 mm mit Adapter möglich. Siehe Art. 20 1660 Seite 388.
Achtung: Die Zollabmessungen entsprechen nicht exakt den mm Durchmessern.
Larger Ø up to 55 mm with adapter possible. See Art. 20 1660 page 388.
Attention: The inch sizes do not correspond exactly to the mm diameters.

20 1660N

HARD-LINE / 110

ZUBEHÖR • ACCESSORIES



AUSWERFERSTIFTE • EJECTOR PINS

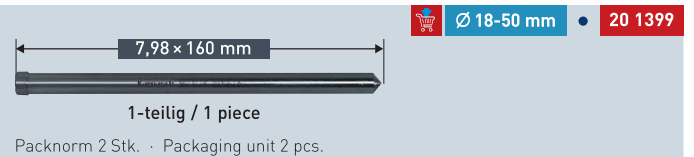
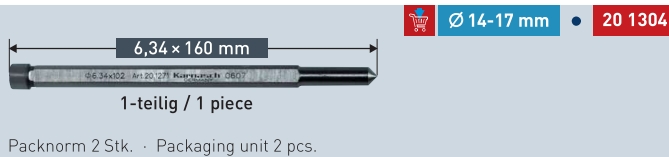

Zusammen mit Aufnahmehalter 20 1842, 20 1291, 20 1843, 20 1845, 20 1846 (siehe Seite 542–543) kann dieser einteilige Auswerferstift verwendet werden. Es kann ohne Umstecken bis 110 mm Schnitttiefe in einem Arbeitsgang gebohrt werden. Robust und einfach.

It is possible to use this one-piece ejector pin in combination with tool holder article 20 1842, 20 1291, 20 1843, 20 1845, 20 1846 (see page 542–543). You can drill as deep as 110 mm in one working process without changing. Robust and easy.

AUSWERFERSTIFTE 2-TEILIG EJECTOR PINS 2-PIECE

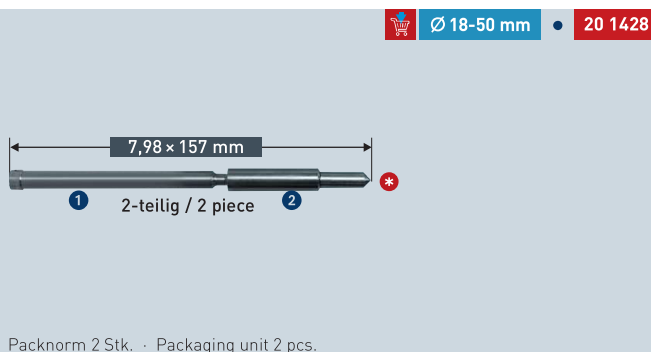

ANWENDUNG AUSWERFERSTIFTE 2-TEILIG APPLICATION EJECTOR PINS 2-PIECE



Anwendung:
Teil 1 in den Schaft des Kernbohrers einführen. Teil 2 auf Teil 1 schieben. Bohren Sie bis ca. 50 mm Schnitttiefe. Danach Teil 2 entfernen und weiter bohren.

Application:
Insert piece 1 into the annular cutter shank. Push piece 2 onto part 1. Drill as deep as 50 mm cutting depth. Then remove piece 2 and continue drilling.

☞ **Warum 2-teilige Auswerferstifte?** In der Regel haben Standard Morsekonus-Aufnahmehalter eine Schnitttiefenkapazität von 50 mm. Wenn **keine extra langen** Aufnahmehalter verwendet werden (wie auf Seite 542–543 Art. 20 1842, 20 1291, 20 1843, 20 1845, 20 1846), müssen bei Schnitttiefen über 50 mm 2-teilige Auswerferstifte verwendet werden.

☞ **Why use 2-part ejector pins?** Usually, standard morse taper holders have a cutting depth capacity of 50 mm. If **no extra-long** holders are used (e.g. as on page 542–543 Art. 20 1842, 20 1291, 20 1843, 20 1845, 20 1846), you need for drill depths above 50 mm 2-part ejector pins.

Schnittdaten
Cutting data

Film
Movie



1487

Zubehör für Hartmetall-bestückte Kernbohrer, Nitto/Universalschaft, Nutzlänge 110 mm
 Accessories for carbide-tipped annular cutter, Nitto/Universal shank, drill depth 110 mm | 4"

HARD-LINE 110

20 1660N

ADAPTER + PASSENDE AUSWERFERSTIFTE · ADAPTER + SUITABLE EJECTOR PINS



• 20 0048



• Ø 18-50 mm • 20 1161

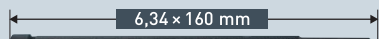

• Ø 14-17 mm • 20 1304

1-teilig / 1 piece

Packnorm 2 Stk. · Packaging unit 2 pcs.



• 20 1438

Packnorm 2 Stk. · Packaging unit 2 pcs.



• Ø 18-50 mm • 20 1399

1-teilig / 1 piece

Packnorm 2 Stk. · Packaging unit 2 pcs.



• Ø 18-50 mm • 20 1428

Packnorm 2 Stk. · Packaging unit 2 pcs.

Ersatz-Innensechskantschrauben für alle Adapter siehe Seite 550
 Spare allen screws for all adapters see page 550

ZUBEHÖR · SETS · DISPLAYS · ERSATZTEILE / ACCESSORIES · SETS · DISPLAYS · SPARE PARTS

Aufnahmehalter mit Morsekonus 2 / 3 / 4 / 5 und Reduzierhülsen 541-543
 Tool holders with morse taper 2 / 3 / 4 / 5 and reduction sleeves



Kühlmittel-Druckflaschen 548
 Coolant pressure bottles



Kegelsenker mit Weldonchaft 544/545
 Countersinks with Weldon shank

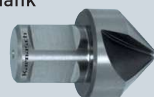

Magnetstab zur Entfernung der Bohrspäne 549
 Magnetic stick for chip removal



Spiralbohradapter Weldon + Spiralbohrer Ø 2,5-12 mm 648
 Twist drill adaptors Weldon + twist drills Ø 2,5-12 mm



Sets · Displays 553-582
 Sets · Displays

Gewindeadapter Weldon + Gewindebohrer M 3 - M 30 649-650
 Tapping adapter Weldon + taps M 3 - M 30



Vollhartmetall Gewindebohrer-Ausbohrer 652
 Solid carbide drills to remove jammed taps



Adapter + passende Bohrfutter 548
 Adapters + suitable drill chucks

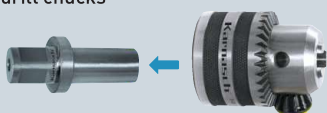

Ersatzteile 550-552
 Spare parts

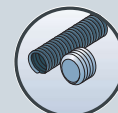

- 1
- 2
- 3
- 4
- 5
- 6
- 7
- 8
- 9
- 10

20 1630

HARD-LINE
ZOLL / INCH **40**

Hartmetall-bestückter Kernbohrer, Nitto/Universalschaft, Nutzlänge 40 mm
Carbide-tipped annular cutter, Nitto/Universal shank, drill depth 40 mm | 1.1/2"



ANWENDUNG • APPLICATION

Stahl	Edelstahl	Grauguss	Alu	Kupfer, Messing, Zinn	Kunststoffe GFK/CFK	Hastelloy, Inconel, Exotische Materialien
Steel	Stainless	Grey cast iron	Alu	Copper, brass, tin	Plastics GRP/CRP	Hastelloy, Inconel, exotic materials
< 1400 N	> 900 N		> 10% Si			

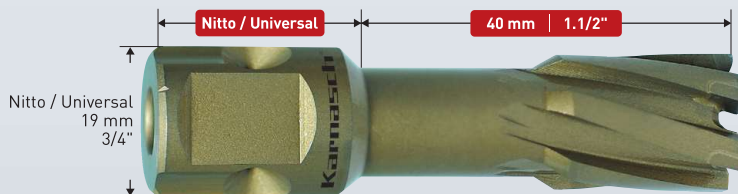

Zoll/Inch	Ø mm	Art.
• 1/2"	12,70	20 1630 010
• 9/16"	14,28	20 1630 015
• 5/8"	15,87	20 1630 020
• 11/16"	17,46	20 1630 025
• 3/4"	19,04	20 1630 030
• 13/16"	20,63	20 1630 035
• 7/8"	22,22	20 1630 040
• 15/16"	23,81	20 1630 045

Zoll/Inch	Ø mm	Art.
• 1"	25,40	20 1630 050
• 1.1/16"	26,98	20 1630 055
• 1.1/8"	28,57	20 1630 060
• 1.3/16"	30,13	20 1630 065
• 1.1/4"	31,75	20 1630 070
• 1.5/16"	33,33	20 1630 075
• 1.3/8"	34,92	20 1630 080
• 1.7/16"	36,51	20 1630 085

Zoll/Inch	Ø mm	Art.
• 1.1/2"	38,10	20 1630 090
• 1.9/16"	39,68	20 1630 095
• 1.5/8"	41,27	20 1630 100
• 1.11/16"	42,86	20 1630 105
• 1.3/4"	44,45	20 1630 110
• 1.13/16"	46,03	20 1630 115
• 1.7/8"	47,62	20 1630 120
• 1.15/16"	49,21	20 1630 125

Zoll/Inch	Ø mm	Art.
• 2"	50,80	20 1630 130
• 2.1/16"	52,38	20 1630 135

Achtung: Die Zollabmessungen entsprechen nicht exakt den mm Durchmesser.
Attention: The inch sizes do not correspond exactly to the mm diameters.

20 1630

HARD-LINE
ZOLL / INCH **40**

ZUBEHÖR • ACCESSORIES



AUSWERFERSTIFTE • EJECTOR PINS



• 20 1149

Packnorm 2 Stk. • Packaging unit 2 pcs.

20 1630

HARD-LINE
ZOLL / INCH **40**

SETS / DISPLAYS Seite / Page 570



Wir bieten eine große Auswahl an Sets / Displays – Inhaltsvorschläge 20 1630 HARD-LINE40 – siehe Seite 570. Anderer Inhalt auf Wunsch möglich, durch individuell bestückbare Sets / Displays.
We offer a large selection of sets / displays – recommended content 20 1630 HARD-LINE40 – see page 570. Other content possible by individually equipped sets / displays.



Schnittdaten
Cutting data

Film
Movie



1487

Zubehör für Hartmetall-bestückte Kernbohrer, Nitto/Universalschaft, Nutzlänge 40 mm
 Accessories for carbide-tipped annular cutter, Nitto/Universal shank, drill depth 40 mm | 1.1/2"

HARD-LINE 40 20 1630
 ZOLL/INCH

ADAPTER + PASSENDE AUSWERFERSTIFTE
ADAPTER + SUITABLE EJECTOR PINS



• 20 1263



• 20 1318

Packnorm 2 Stk. · Packaging unit 2 pcs.



• 21 0048



• 20 1149

Packnorm 2 Stk. · Packaging unit 2 pcs.

Ersatz-Innensechskantschrauben für alle Adapter siehe Seite 550
 Spare allen screws for all adapters see page 550

VERLÄNGERUNGEN + PASSENDE AUSWERFERSTIFTE
EXTENSIONS + SUITABLE EJECTOR PINS



• 20 1406

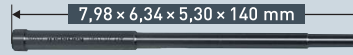

• 20 1390

Packnorm 2 Stk. · Packaging unit 2 pcs.

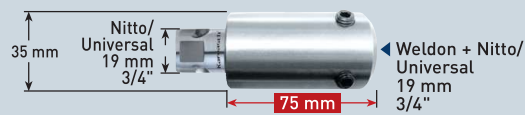

• 20 1407

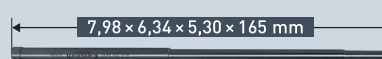

• 20 1405

Packnorm 2 Stk. · Packaging unit 2 pcs.



• 20 1409

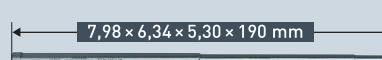

• 20 1420

Packnorm 2 Stk. · Packaging unit 2 pcs.

Ersatz-Innensechskantschrauben für alle Verlängerungen siehe Seite 550
 Spare allen screws for all extensions see page 550

ZUBEHÖR • SETS • DISPLAYS • ERSATZTEILE / ACCESSORIES • SETS • DISPLAYS • SPARE PARTS

Aufnahmehalter mit Morsekonus 2 / 3 / 4 / 5 und Reduzierhülsen  541-543
 Tool holders with morse taper 2 / 3 / 4 / 5 and reduction sleeves



Kühlmittel-Druckflaschen  548
 Coolant pressure bottles



Kegelsenker mit Weldonschaft  544/545
 Countersinks with Weldon shank

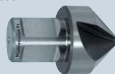

Magnetstab zur Entfernung der Bohrspäne  549
 Magnetic stick for chip removal



Spiralbohradapter Weldon + Spiralbohrer Ø 2,5-12 mm  648
 Twist drill adaptors Weldon + twist drills Ø 2,5-12 mm



Sets · Displays  553-582
 Sets · Displays



Gewindeadapter Weldon + Gewindebohrer M 3 - M 30  649-650
 Tapping adapter Weldon + taps M 3 - M 30



Adapter + passende Bohrfutter  548
 Adapters + suitable drill chucks

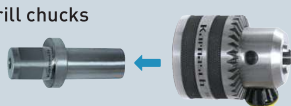

Ersatzteile  550-552
 Spare parts



- 1
- 2
- 3
- 4
- 5
- 6
- 7
- 8
- 9
- 10

20 1640

HARD-LINE
ZOLL / INCH **55**

Hartmetall-bestückter Kernbohrer, Nitto/Universalschaft, Nutzlänge 55 mm
Carbide-tipped annular cutter, Nitto/Universal shank, drill depth 55 mm | 2"



ANWENDUNG • APPLICATION

Stahl	Edelstahl	Grauguss	Alu	Kupfer, Messing, Zinn	Kunststoffe GFK/CFK	Hastelloy, Inconel, Exotische Materialien
Steel	Stainless	Grey cast iron	Alu	Copper, brass, tin	Plastics GRP/CRP	Hastelloy, Inconel, exotic materials
< 1400 N	> 900 N		> 10% Si			

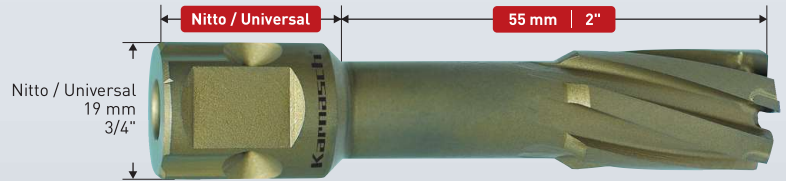

Zoll/Inch	Ø mm	Art.	Zoll/Inch	Ø mm	Art.	Zoll/Inch	Ø mm	Art.	Zoll/Inch	Ø mm	Art.
• 1/2"	12,70	20 1640 010	• 1"	25,40	20 1640 050	• 1.1/2"	38,10	20 1640 090	• 2"	50,80	20 1640 130
• 9/16"	14,28	20 1640 015	• 1.1/16"	26,98	20 1640 055	• 1.9/16"	39,68	20 1640 095	• 2.1/16"	52,38	20 1640 135
• 5/8"	15,87	20 1640 020	• 1.1/8"	28,57	20 1640 060	• 1.5/8"	41,27	20 1640 100			
• 11/16"	17,46	20 1640 025	• 1.3/16"	30,13	20 1640 065	• 1.11/16"	42,86	20 1640 105			
• 3/4"	19,04	20 1640 030	• 1.1/4"	31,75	20 1640 070	• 1.3/4"	44,45	20 1640 110			
• 13/16"	20,63	20 1640 035	• 1.5/16"	33,33	20 1640 075	• 1.13/16"	46,03	20 1640 115			
• 7/8"	22,22	20 1640 040	• 1.3/8"	34,92	20 1640 080	• 1.7/8"	47,62	20 1640 120			
• 15/16"	23,81	20 1640 045	• 1.7/16"	36,51	20 1640 085	• 1.15/16"	49,21	20 1640 125			

Achtung: Die Zollabmessungen entsprechen nicht exakt den mm Durchmesser.
Attention: The inch sizes do not correspond exactly to the mm diameters.

20 1640

HARD-LINE
ZOLL / INCH **55**

ZUBEHÖR • ACCESSORIES



AUSWERFERSTIFTE • EJECTOR PINS



• 20 1271

Packnorm 2 Stk. • Packaging unit 2 pcs.

20 1640

HARD-LINE
ZOLL / INCH **55**

SETS / DISPLAYS Seite / Page 571



Wir bieten eine große Auswahl an Sets / Displays – Inhaltsvorschläge 20 1640 HARD-LINE55 – siehe Seite 571. Anderer Inhalt auf Wunsch möglich, durch individuell bestückbare Sets / Displays.
We offer a large selection of sets / displays – recommended content 20 1640 HARD-LINE55 – see page 571. Other content possible by individually equipped sets / displays.



Schnittdaten
Cutting data

Film
Movie



1487

- 1
- 2
- 3
- 4
- 5
- 6
- 7
- 8
- 9
- 10

Zubehör für Hartmetall-bestückte Kernbohrer, Nitto/Universalschaft, Nutzlänge 55 mm
 Accessories for carbide-tipped annular cutter, Nitto/Universal shank, drill depth 55 mm | 2"

HARD-LINE 55 ZOLL/INCH 20 1640

ADAPTER + PASSENDE AUSWERFERSTIFTE
ADAPTER + SUITABLE EJECTOR PINS

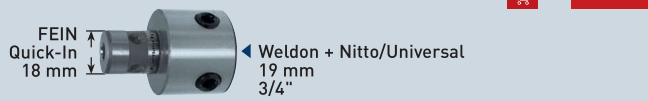

• 20 1263



• 20 1160

Packnorm 2 Stk. · Packaging unit 2 pcs.

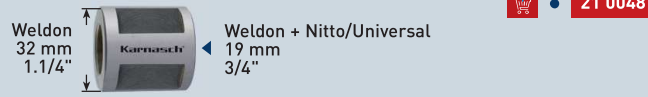

• 21 0048



• 20 1271

Packnorm 2 Stk. · Packaging unit 2 pcs.

Ersatz-Innensechskantschrauben für alle Adapter siehe Seite 550
 Spare allen screws for all adapters see page 550

VERLÄNGERUNGEN + PASSENDE AUSWERFERSTIFTE
EXTENSIONS + SUITABLE EJECTOR PINS



• 20 1406



• 20 1396

Packnorm 2 Stk. · Packaging unit 2 pcs.



• 20 1407



• 20 1411

Packnorm 2 Stk. · Packaging unit 2 pcs.



• 20 1409



• 20 1426

Packnorm 2 Stk. · Packaging unit 2 pcs.

Ersatz-Innensechskantschrauben für alle Verlängerungen siehe Seite 550
 Spare allen screws for all extensions see page 550

ZUBEHÖR • SETS • DISPLAYS • ERSATZTEILE / ACCESSORIES • SETS • DISPLAYS • SPARE PARTS

Aufnahmehalter mit Morsekonus 2 / 3 / 4 / 5 und Reduzierhülsen
 Tool holders with morse taper 2 / 3 / 4 / 5 and reduction sleeves

541-543



Kühlmittel-Druckflaschen
 Coolant pressure bottles

548



Kegelsenker mit Weldonschaft
 Countersinks with Weldon shank

544/545

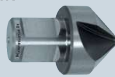

Magnetstab zur Entfernung der Bohrspäne
 Magnetic stick for chip removal

549



Spiralbohradapter Weldon + Spiralbohrer Ø 2,5-12 mm
 Twist drill adaptors Weldon + twist drills Ø 2,5-12 mm

648



Sets · Displays
 Sets · Displays

553-582



Gewindeadapter Weldon + Gewindebohrer M 3 - M 30
 Tapping adapter Weldon + taps M 3 - M 30

649-650



Adapter + passende Bohrfutter
 Adapters + suitable drill chucks

548

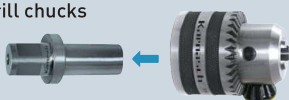

Ersatzteile
 Spare parts

550-552



20 1670

HARD-LINE
ZOLL / INCH **80**

Hartmetall-bestückter Kernbohrer, Nitto/Universalschaft, Nutzlänge 80 mm
Carbide-tipped annular cutter, Nitto/Universal shank, drill depth 80 mm | 3"



ANWENDUNG • APPLICATION

Stahl	Edelstahl	Grauguss	Alu	Kupfer, Messing, Zinn	Kunststoffe GFK/CFK	Hastelloy, Inconel, Exotische Materialien
Steel	Stainless	Grey cast iron	Alu	Copper, brass, tin	Plastics GRP/CRP	Hastelloy, Inconel, exotic materials
< 1400 N	> 900 N		> 10% Si			

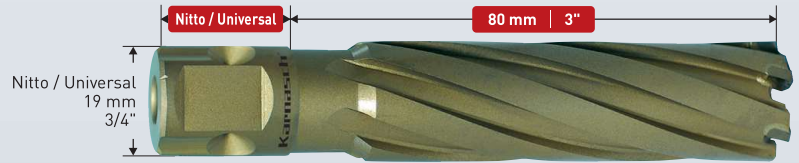

Zoll/Inch	Ø mm	Art.	Zoll/Inch	Ø mm	Art.	Zoll/Inch	Ø mm	Art.	Zoll/Inch	Ø mm	Art.
• 11/16"	17,46	20 1670 025	• 1.1/16"	26,98	20 1670 055	• 1.7/16"	36,51	20 1670 085	• 1.13/16"	46,03	20 1670 115
• 3/4"	19,04	20 1670 030	• 1.1/8"	28,57	20 1670 060	• 1.1/2"	38,10	20 1670 090	• 1.7/8"	47,62	20 1670 120
• 13/16"	20,63	20 1670 035	• 1.3/16"	30,13	20 1670 065	• 1.9/16"	39,68	20 1670 095	• 1.15/16"	49,21	20 1670 125
• 7/8"	22,22	20 1670 040	• 1.1/4"	31,75	20 1670 070	• 1.5/8"	41,27	20 1670 100	• 2"	50,80	20 1670 130
• 15/16"	23,81	20 1670 045	• 1.5/16"	33,33	20 1670 075	• 1.11/16"	42,86	20 1670 105	• 2.1/16"	52,38	20 1670 135
• 1"	25,40	20 1670 050	• 1.3/8"	34,92	20 1670 080	• 1.3/4"	44,45	20 1670 110			

Achtung: Die Zollabmessungen entsprechen nicht exakt den mm Durchmessern.
Attention: The inch sizes do not correspond exactly to the mm diameters.

20 1670

HARD-LINE
ZOLL / INCH **80**

ZUBEHÖR • ACCESSORIES



AUSWERFERSTIFTE 1-TEILIG • EJECTOR PINS 1-PIECE

• 20 1439



1-teilig / 1 piece

Packnorm 2 Stk. · Packaging unit 2 pcs.

Zusammen mit Aufnahmehalter 20 1842, 20 1291, 20 1843, 20 1845, 20 1846 (siehe Seite 542–543) kann dieser einteilige Auswerferstift verwendet werden. Es kann ohne Umstecken bis 110 mm Schnitttiefe in einem Arbeitsgang gebohrt werden. Robust und einfach.

It is possible to use this one-piece ejector pin in combination with tool holder article 20 1842, 20 1291, 20 1843, 20 1845, 20 1846 (see page 542–543). You can drill as deep as 110 mm in one working process without changing. Robust and easy.

AUSWERFERSTIFTE 2-TEILIG EJECTOR PINS 2-PIECE

• 20 1427

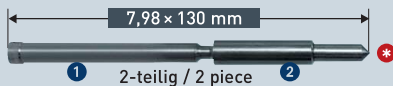

2-teilig / 2 piece

Packnorm 2 Stk. · Packaging unit 2 pcs.

ANWENDUNG AUSWERFERSTIFTE 2-TEILIG APPLICATION EJECTOR PINS 2-PIECE



Anwendung:

Teil 1 in den Schaft des Kernbohrers einführen. Teil 2 auf Teil 1 schieben. Bohren Sie bis ca. 50 mm Schnitttiefe. Danach Teil 2 entfernen und weiter bohren.

Application:

Insert piece 1 into the annular cutter shank. Push piece 2 onto part 1. Drill as deep as 50 mm cutting depth. Then remove piece 2 and continue drilling.

• **Warum 2-teilige Auswerferstifte?** In der Regel haben Standard Morsekonus-Aufnahmehalter eine Schnitttiefenkapazität von 50 mm. Wenn **keine extra langen** Aufnahmehalter verwendet werden (wie auf Seite 542–543 Art. 20 1842, 20 1291, 20 1843, 20 1845, 20 1846), müssen bei Schnitttiefen über 50 mm 2-teilige Auswerferstifte verwendet werden.

• **Why use 2-part ejector pins?** Usually, standard morse taper holders have a cutting depth capacity of 50 mm. If **no extra-long** holders are used (e.g. as on page 542–543 Art. 20 1842, 20 1291, 20 1843, 20 1845, 20 1846), you need for drill depths above 50 mm 2-part ejector pins.

Schnittdaten
Cutting data

Film
Movie



1487





Zubehör für Hartmetall-bestückte Kernbohrer, Nitto/Universalschaft, Nutzlänge 80 mm
 Accessories for carbide-tipped annular cutter, Nitto/Universal shank, drill depth 80 mm | 3"

HARD-LINE / 80 ZOLL / INCH **20 1670**

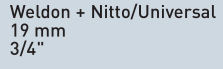
ADAPTER + PASSENDE AUSWERFERSTIFTE
ADAPTER + SUITABLE EJECTOR PINS

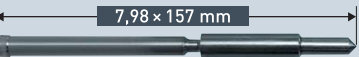

FEIN Quick-In 18 mm  Weldon + Nitto/Universal 19 mm 3/4"  **20 1161**

 7,98 x 157 mm  **20 1436**

1 2-teilig / 2 piece 2

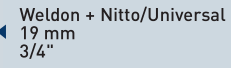

Packnorm 2 Stk. · Packaging unit 2 pcs.

Weldon 32 mm 1.1/4"  Weldon + Nitto/Universal 19 mm 3/4"  **21 0048**

 7,98 x 130 mm  **20 1439**

1-teilig / 1 piece

Packnorm 2 Stk. · Packaging unit 2 pcs.

 7,98 x 130 mm  **20 1427**

1 2-teilig / 2 piece 2

Packnorm 2 Stk. · Packaging unit 2 pcs.

Ersatz-Innensechskantschrauben für alle Adapter siehe Seite 550
 Spare allen screws for all adapters see page 550

ZUBEHÖR · SETS · DISPLAYS · ERSATZTEILE / ACCESSORIES · SETS · DISPLAYS · SPARE PARTS

Aufnahmehalter mit Morsekonus 2 / 3 / 4 / 5 und Reduzierhülsen  **541-543**
 Tool holders with morse taper 2 / 3 / 4 / 5 and reduction sleeves

Kühlmittel-Druckflaschen  **548**
 Coolant pressure bottles

Kegelsenker mit Weldonchaft  **544/545**
 Countersinks with Weldon shank

Magnetstab zur Entfernung der Bohrspäne  **549**
 Magnetic stick for chip removal

Spiralbohradapter Weldon + Spiralbohrer Ø 2,5-12 mm  **648**
 Twist drill adaptors Weldon + twist drills Ø 2,5-12 mm

Sets · Displays  **553-582**
 Sets · Displays

Gewindeadapter Weldon + Gewindebohrer M 3 - M 30  **649-650**
 Tapping adapter Weldon + taps M 3 - M 30

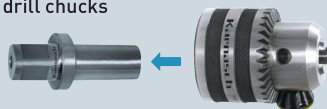
Adapter + passende Bohrfutter  **548**
 Adapters + suitable drill chucks

Ersatzteile  **550-552**
 Spare parts



HSS-XE + DURABLUE BESCHICHTETE KERNBOHRER HSS-XE + DURABLUE-COATED ANNULAR CUTTERS



BLUE-DRILL LINE

Neben Hartmetall-bestückten Kernbohrern bieten beschichtete HSS-XE Kernbohrer das optimale Preis-Leistungs-Verhältnis.

Im harten Einsatz kann nur in den seltensten Fällen auf optimale Drehzahlen und Kühlung Rücksicht genommen werden. Die Karnasch DURABLUE-Beschichtung macht den Kernbohrer somit entscheidend widerstandsfähiger. Letztendlich wird dadurch die Lebensdauer des Bohrers wesentlich erhöht.

BLUE-DRILL LINE ist der am häufigsten verwendete Karnasch Kernbohrer. Der HSS-XE Bohrer mit dem besten Preis-Leistungs-Verhältnis für alle Stähle bis 40 Rockwell (HRC) Festigkeit sowie Edelstähle.

Carbide tipped annular cutters and coated HSS-XE cutters provide the optimal price-performance ratio.

Under hard field conditions only in the rarest cases optimum speed and cooling can be considered. The Karnasch DURABLUE-coating makes the annular cutter decisively more resistant. This results in a considerable increase in product life.

BLUE-DRILL LINE annular cutters are the most commonly used Karnasch cutters. These HSS-XE cutters offers the best price-performance ratio for all steels up to a strength of 40 Rockwell (HRC) and stainless steel.

EIGENSCHAFTEN · PROPERTIES



Gefertigt aus hochlegiertem HSS-XE Spezialstahl. Für extreme Härte an den Zahnspitzen (bis 68 HRC). Somit hohe Verschleißfestigkeit und Standzeit.

Made of high-alloyed HSS-XE special steel. For extreme hardness at the tip of the tooth (up to 68 HRC). A high wear resistance and lifetime.

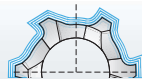

Unsere hochwertigsten Kernbohrer erhalten die einzigartige und patentierte DURABLUE-Beschichtung. Extreme Oberflächenhärte- und -glätte ergeben extreme Standzeiten auch unter nicht optimalen Arbeitsbedingungen wie „Über Kopf arbeiten“, Trockenbohrungen, u.s.w.

Our first-class annular cutters are equipped with the unique and patented DURABLUE-coating. Extreme surface hardness and sleekness yield extreme lifetimes even under non-optimum conditions like "overhead work", dry drilling, etc.



Nur wenige Hersteller sind in der Lage in Stufen gehärtete Kernbohrer zu fertigen. Für uns ist dies „Standard“. Dadurch erreichen wir extrem harte Zahnspitzen (68 HRC) und dennoch einen flexiblen Kernbohrer.

Only few manufacturers are capable of producing step-hardened annular cutters. For Karnasch this is "standard". Only this makes us produce extremely hard tooth tips (68 HRC) and yet a flexible annular cutter.

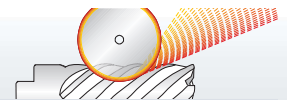

Aus dem vollen Material komplett geschliffen. Dieser Feinschliff erhöht die Zerspanleistung bei gleichzeitiger Reduzierung der Reibung. Für ein Mehr an Standzeit.

Completely made "FULLY GROUND". This refining increases the cutting ability while reducing friction at the same time. For an extended lifetime.

ANWENDUNG · APPLICATION

Stahl	Stahl	Stahl	Edelstahl	Edelstahl	Alu	Alu	Kupfer, Messing, Zinn	Kunststoffe GFK/CFK	Grauguss	Hastelloy, Inconel, Nimonic, Exotische Materialien	Hardox 400	Hardox 450
Steel	Steel	Steel	Stainless	Stainless	Alu	Alu	Copper, brass, tin	Plastics GRP/CRP	Grey cast iron	Hastelloy, Inconel, Nimonic, exotic materials	Hardox 400	Hardox 450
< 900 N	< 1100 N	< 1400 N	< 900 N	> 900 N	< 10% Si	> 10% Si						
✓	✓	✓	✓	✓	✓	✓	✓	✓	✓	✓	✓	✓

✓ OPTIMAL · OPTIMAL

✓ GUT · GOOD

✓ MÖGLICH · POSSIBLE

HSS-XE + DURABLUK BESCHICHTETE KERNBOHRER HSS-XE + DURABLUK-COATED ANNULAR CUTTERS

Schnitttiefe · Drill depths	Ø mm	Ø Zoll / Inch	Art. / Type	
 Nitto / Universal 30 mm 1"	12-60	15/32-2.23/64"	20 1312N BLUE-DRILL LINE / 30	470
 Nitto / Universal 55 mm 2"	12-60	15/32-2.23/64"	20 1313N BLUE-DRILL LINE / 55	472
 Nitto / Universal 80 mm 3"	18-50	45/64-1.31/32"	20 1185N BLUE-DRILL LINE / 80	474
 Nitto / Universal 110 mm 4"	18-50	45/64-1.31/32"	20 1180N BLUE-DRILL LINE / 110	476
 Nitto / Universal 30 mm 1"	-	7/16-1.7/8"	20 1611 BLUE-DRILL LINE ZOLL / INCH / 30	478
 Nitto / Universal 55 mm 2"	-	7/16-1.7/8"	20 1621 BLUE-DRILL LINE ZOLL / INCH / 55	480
 Nitto / Universal 80 mm 3"	-	11/16-2.1/16"	20 1125 BLUE-DRILL LINE ZOLL / INCH / 80	482

ZUBEHÖR · SETS · DISPLAYS · ERSATZTEILE / ACCESSORIES · SETS · DISPLAYS · SPARE PARTS

Aufnahmehalter mit Morsekonus 2 / 3 / 4 / 5 und Reduzierhülsen 541-543
Tool holders with morse taper 2 / 3 / 4 / 5 and reduction sleeves



Kühlmittel-Druckflaschen 548
Coolant pressure bottles



Kegelsenker mit Weldonchaft 544/545
Countersinks with Weldon shank

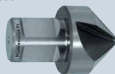

Magnetstab zur Entfernung der Bohrspäne 549
Magnetic stick for chip removal

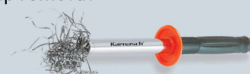

Spiralbohradapter Weldon + Spiralbohrer Ø 2,5-12 mm 648
Twist drill adaptors Weldon + twist drills Ø 2,5-12 mm



Sets · Displays 553-582
Sets · Displays



Gewintheadapter Weldon + Gewindebohrer M 3 - M 30 649-650
Tapping adapter Weldon + taps M 3 - M 30



Adapter + passende Bohrfutter 548
Adapters + suitable drill chucks

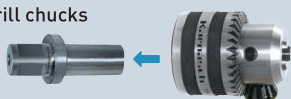

Ersatzteile 550-552
Spare parts



- 1
- 2
- 3
- 4
- 5
- 6
- 7
- 8
- 9
- 10

20 1312N

BLUE-DRILL LINE/30

HSS-XE + DURABLUe-beschichteter Kernbohrer, Nitto/Universalschaft, Nutzlänge 30 mm
HSS-XE + DURABLUe-coated annular cutter, Nitto/Universal shank, drill depth 30 mm | 1"



ANWENDUNG • APPLICATION

Stahl	Edelstahl	Grauguss	Alu	Kupfer, Messing, Zinn	Kunststoffe GFK/CFK	Hardox 400, 450
Steel	Stainless	Grey cast iron	Alu	Copper, brass, tin	Plastics GRP/CRP	Hardox 400, 450
< 1100 N	< 900 N		> 10% Si			

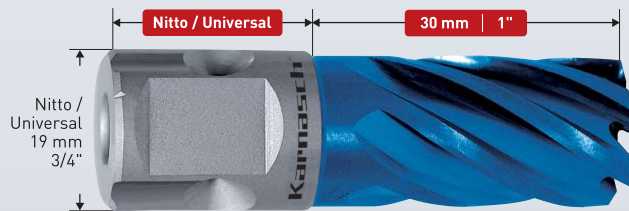

☞ Sonderpreis / Sale Artikel. Lieferbar solange Vorrat.
Special price / sale article. While stocks last.

Art.	Ø mm	Ø Zoll Inch	Art.	Ø mm	Ø Zoll Inch	Art.	Ø mm	Ø Zoll Inch	Art.	Ø mm	Ø Zoll Inch
20 1312N 012	• 12	15/32"	20 1312N 026	• 26	1.17/32"	20 1312N 040	• 40	1.37/64"	20 1312N 054	☞ 54	2.1/8"
20 1312N 013	• 13	33/64"	20 1312N 027	• 27	1.1/16"	20 1312N 041	☞ 41	1.39/64"	20 1312N 055	☞ 55	2.11/64"
20 1312N 014	• 14	35/64"	20 1312N 028	• 28	1.7/64"	20 1312N 042	☞ 42	1.21/32"	20 1312N 056	☞ 56	2.13/64"
20 1312N 015	• 15	19/32"	20 1312N 029	• 29	1.9/64"	20 1312N 043	☞ 43	1.11/16"	20 1312N 057	☞ 57	2.1/4"
20 1312N 016	• 16	5/8"	20 1312N 030	• 30	1.3/16"	20 1312N 044	☞ 44	1.47/64"	20 1312N 058	☞ 58	2.9/32"
20 1312N 017	• 17	43/64"	20 1312N 031	• 31	1.7/32"	20 1312N 045	• 45	1.49/64"	20 1312N 059	☞ 59	2.21/64"
20 1312N 018	• 18	45/64"	20 1312N 032	• 32	1.17/64"	20 1312N 046	☞ 46	1.13/16"			
20 1312N 019	• 19	3/4"	20 1312N 033	• 33	1.19/64"	20 1312N 047	☞ 47	1.27/32"			
20 1312N 020	• 20	25/32"	20 1312N 034	• 34	1.11/32"	20 1312N 048	☞ 48	1.57/64"			
20 1312N 021	• 21	53/64"	20 1312N 035	• 35	1.3/8"	20 1312N 049	☞ 49	1.59/64"			
20 1312N 022	• 22	55/64"	20 1312N 036	• 36	1.27/64"	20 1312N 050	• 50	1.31/32"			
20 1312N 023	☞ 23	29/32"	20 1312N 037	• 37	1.29/64"	20 1312N 051	☞ 51	2.1/64"			
20 1312N 024	• 24	15/16"	20 1312N 038	• 38	1.1/2"	20 1312N 052	☞ 52	2.3/64"			
20 1312N 025	• 25	63/64"	20 1312N 039	• 39	1.17/32"	20 1312N 053	☞ 53	2.3/32"			

Ersatzartikel siehe Art. 20 1260N
Seite 486, Art. 20 1315N Seite 454
Replacement article see Art. 20 1260N
page 486, Art. 20 1315N page 454

Größere Ø siehe Art. 20 1315 Seite 382 sowie Art. 20 1316 Seite 384 – Größere Ø bis 100 mm siehe Art. 20 1130A + Adapter Seite 595/597 ·
Achtung: Die Zollabmessungen entsprechen nicht exakt den mm Durchmessern.

Larger Ø see Art. 20 1315 page 382 and Art. 20 1316 page 384 – Larger Ø up to 100 mm see Art. 20 1130A + adapter page 595/597 ·
Attention: The inch sizes do not correspond exactly to the mm diameters.

20 1312N

BLUE-DRILL LINE/30

ZUBEHÖR • ACCESSORIES

AUSWERFERSTIFTE • EJECTOR PINS



☞ 20 1261

Packnorm 2 Stk. · Packaging unit 2 pcs.

20 1312N

BLUE-DRILL LINE/30

SETS / DISPLAYS Seite / Page 572

Wir bieten eine große Auswahl an Sets / Displays – Inhaltsvorschläge 20 1312N BLUE-DRILL LINE30 – siehe Seite 572. Anderer Inhalt auf Wunsch möglich, durch individuell bestückbare Sets / Displays.

We offer a large selection of sets / displays – recommended content 20 1312N BLUE-DRILL LINE30 – see page 572. Other content possible by individually equipped sets / displays.



Schnittdaten
Cutting data

Film
Movie



1488

Zubehör für HSS-XE + DURABLU-beschichteten Kernbohrer, Nitto/Universalschaft, Nutzlänge 30 mm
 Accessories for HSS-XE + DURABLU-coated annular cutter, Nitto/Universal shank, drill depth 30 mm | 1"

BLUE-DRILL LINE 30 **20 1312N**

ADAPTER + PASSENDE AUSWERFERSTIFTE
ADAPTER + SUITABLE EJECTOR PINS



• 20 1263



• 20 1271

Packnorm 2 Stk. · Packaging unit 2 pcs.



• 21 0048



• 20 1261

Packnorm 2 Stk. · Packaging unit 2 pcs.

Ersatz-Innensechskantschrauben für alle Adapter siehe Seite 550
 Spare allen screws for all adapters see page 550

VERLÄNGERUNGEN + PASSENDE AUSWERFERSTIFTE
EXTENSIONS + SUITABLE EJECTOR PINS

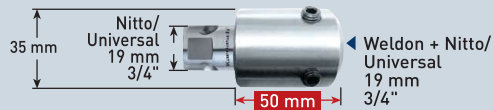

• 20 1406

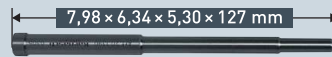

• 20 1433

Packnorm 2 Stk. · Packaging unit 2 pcs.



• 20 1407



• 20 1396

Packnorm 2 Stk. · Packaging unit 2 pcs.



• 20 1409



• 20 1411

Packnorm 2 Stk. · Packaging unit 2 pcs.

Ersatz-Innensechskantschrauben für alle Verlängerungen siehe Seite 550
 Spare allen screws for all extensions see page 550

ZUBEHÖR • SETS • DISPLAYS • ERSATZTEILE / ACCESSORIES • SETS • DISPLAYS • SPARE PARTS

Aufnahmehalter mit Morsekonus 2 / 3 / 4 / 5 und Reduzierhülsen
 Tool holders with morse taper 2 / 3 / 4 / 5 and reduction sleeves

☞ 541-543



Kühlmittel-Druckflaschen
 Coolant pressure bottles

☞ 548



Kegelsenker mit Weldonschaft
 Countersinks with Weldon shank

☞ 544/545

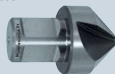

Magnetstab zur Entfernung der Bohrspäne
 Magnetic stick for chip removal

☞ 549



Spiralbohradapter Weldon + Spiralbohrer Ø 2,5-12 mm
 Twist drill adaptors Weldon + twist drills Ø 2,5-12 mm

☞ 648



Sets · Displays
 Sets · Displays

☞ 553-582



Gewindeadapter Weldon + Gewindebohrer M 3 - M 30
 Tapping adapter Weldon + taps M 3 - M 30

☞ 649-650



Adapter + passende Bohrfutter
 Adapters + suitable drill chucks

☞ 548

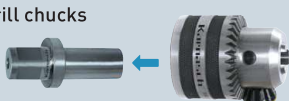

Ersatzteile
 Spare parts

☞ 550-552



20 1313N

BLUE-DRILL LINE/55

HSS-XE + DURABLUe-beschichteter Kernbohrer, Nitto/Universalschaft, Nutzlänge 55 mm
HSS-XE + DURABLUe-coated annular cutter, Nitto/Universal shank, drill depth 55 mm | 2"



ANWENDUNG • APPLICATION

Stahl	Edelstahl	Grauguss	Alu	Kupfer, Messing, Zinn	Kunststoffe GFK/CFK	Hardox 400, 450
Steel	Stainless	Grey cast iron	Alu	Copper, brass, tin	Plastics GRP/CRP	Hardox 400, 450
< 1100 N	< 900 N		> 10% Si			



☞ Sonderpreis / Sale Artikel. Lieferbar solange Vorrat.
Special price / sale article. While stocks last.

Art.	Ø mm	Ø Zoll	Art.	Ø mm	Ø Zoll	Art.	Ø mm	Ø Zoll	Art.	Ø mm	Ø Zoll
20 1313N 012	• 12	15/32"	20 1313N 026	• 26	1.1/32"	20 1313N 040	• 40	1.37/64"	20 1313N 055	☞ 55	2.11/64"
20 1313N 013	• 13	33/64"	20 1313N 027	• 27	1.1/16"	20 1313N 041	☞ 41	1.39/64"	20 1313N 056	☞ 56	2.13/64"
20 1313N 014	• 14	35/64"	20 1313N 028	• 28	1.7/64"	20 1313N 042	☞ 42	1.21/32"	20 1313N 057	☞ 57	2.1/4"
20 1313N 015	• 15	19/32"	20 1313N 029	• 29	1.9/64"	20 1313N 044	☞ 44	1.47/64"	20 1313N 058	☞ 58	2.9/32"
20 1313N 016	• 16	5/8"	20 1313N 030	• 30	1.3/16"	20 1313N 045	• 45	1.49/64"	20 1313N 059	☞ 59	2.21/64"
20 1313N 017	• 17	43/64"	20 1313N 031	• 31	1.7/32"	20 1313N 046	☞ 46	1.13/16"			
20 1313N 018	• 18	45/64"	20 1313N 032	• 32	1.17/64"	20 1313N 047	☞ 47	1.27/32"			
20 1313N 019	• 19	3/4"	20 1313N 033	• 33	1.19/64"	20 1313N 048	☞ 48	1.57/64"			
20 1313N 020	• 20	25/32"	20 1313N 034	• 34	1.11/32"	20 1313N 049	☞ 49	1.59/64"			
20 1313N 021	• 21	53/64"	20 1313N 035	• 35	1.3/8"	20 1313N 050	• 50	1.31/32"			
20 1313N 022	• 22	55/64"	20 1313N 036	• 36	1.27/64"	20 1313N 051	☞ 51	2.1/64"			
20 1313N 023	• 23	29/32"	20 1313N 037	☞ 37	1.29/64"	20 1313N 052	☞ 52	2.3/64"			
20 1313N 024	• 24	15/16"	20 1313N 038	• 38	1.1/2"	20 1313N 053	☞ 53	2.3/32"			
20 1313N 025	• 25	63/64"	20 1313N 039	☞ 39	1.17/32"	20 1313N 054	☞ 54	2.1/8"			

Ersatzartikel siehe Art. 20 1270N
Seite 488, Art. 20 1316N Seite 456
Replacement article see Art. 20 1270N
page 488, Art. 20 1316N page 456

Größere Ø siehe Art. 20 1316 Seite 384 – Größere Ø bis 100 mm siehe Art. 20 1141A + Adapter Seite 599 / 601 ·
Achtung: Die Zollabmessungen entsprechen nicht exakt den mm Durchmessern.
Larger Ø see Art. 20 1316 page 384 – Larger Ø up to 100 mm see Art. 20 1141A + adapter page 599 / 601 ·
Attention: The inch sizes do not correspond exactly to the mm diameters.

20 1313N

BLUE-DRILL LINE/55

ZUBEHÖR • ACCESSORIES



AUSWERFERSTIFTE • EJECTOR PINS



☞ 20 1271

Packnorm 2 Stk. · Packaging unit 2 pcs.

20 1313N

BLUE-DRILL LINE/55

SETS / DISPLAYS Seite / Page 573



Wir bieten eine große Auswahl an Sets / Displays – Inhaltsvorschläge 20 1313N BLUE-DRILL LINE55 – siehe Seite 573. Anderer Inhalt auf Wunsch möglich, durch individuell bestückbare Sets / Displays.
We offer a large selection of sets / displays – recommended content 20 1313N BLUE-DRILL LINE55 – see page 573. Other content possible by individually equipped sets / displays.



Schnittdaten
Cutting data

Film
Movie



1488

Zubehör für HSS-XE + DURABLU- beschichteten Kernbohrer, Nitto/Universalschaft, Nutzlänge 55 mm
 Accessories for HSS-XE + DURABLU-coated annular cutter, Nitto/Universal shank, drill depth 55 mm | 2"

BLUE-DRILL LINE 55 20 1313N

**ADAPTER + PASSENDE AUSWERFERSTIFTE
 ADAPTER + SUITABLE EJECTOR PINS**



• 20 1263



• 20 1160

Packnorm 2 Stk. · Packaging unit 2 pcs.



• 21 0048



• 20 1271

Packnorm 2 Stk. · Packaging unit 2 pcs.

Ersatz-Innensechskantschrauben für alle Adapter siehe Seite 550
 Spare allen screws for all adapters see page 550

**VERLÄNGERUNGEN + PASSENDE AUSWERFERSTIFTE
 EXTENSIONS + SUITABLE EJECTOR PINS**

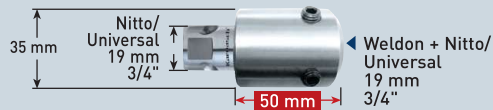

• 20 1406

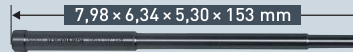

• 20 1396

Packnorm 2 Stk. · Packaging unit 2 pcs.



• 20 1407

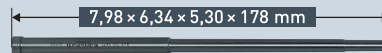

• 20 1411

Packnorm 2 Stk. · Packaging unit 2 pcs.



• 20 1409

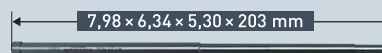

• 20 1426

Packnorm 2 Stk. · Packaging unit 2 pcs.

Ersatz-Innensechskantschrauben für alle Verlängerungen siehe Seite 550
 Spare allen screws for all extensions see page 550

ZUBEHÖR • SETS • DISPLAYS • ERSATZTEILE / ACCESSORIES • SETS • DISPLAYS • SPARE PARTS

Aufnahmelhalter mit Morsekonus 2 / 3 / 4 / 5 und Reduzierhülsen 541-543
 Tool holders with morse taper 2 / 3 / 4 / 5 and reduction sleeves



Kühlmittel-Druckflaschen 548
 Coolant pressure bottles



Kegelsenker mit Weldonschaft 544/545
 Countersinks with Weldon shank

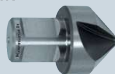

Magnetstab zur Entfernung der Bohrspäne 549
 Magnetic stick for chip removal



Spiralbohradapter Weldon + Spiralbohrer Ø 2,5-12 mm 648
 Twist drill adaptors Weldon + twist drills Ø 2,5-12 mm



Sets · Displays 553-582
 Sets · Displays



Gewindeadapter Weldon + Gewindebohrer M 3 - M 30 649-650
 Tapping adapter Weldon + taps M 3 - M 30



Adapter + passende Bohrfutter 548
 Adapters + suitable drill chucks

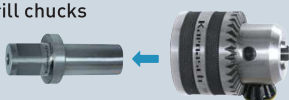

Ersatzteile 550-552
 Spare parts



20 1185N

BLUE-DRILL LINE / 80

HSS-XE + DURABLUe-beschichteter Kernbohrer, Nitto/Universalschaft, Nutzlänge 80 mm
HSS-XE + DURABLUe-coated annular cutter, Nitto/Universal shank, drill depth 80 mm | 3"



ANWENDUNG • APPLICATION

Stahl	Edelstahl	Grauguss	Alu	Kupfer, Messing, Zinn	Kunststoffe GFK/CFK	Hardox 400, 450
Steel	Stainless	Grey cast iron	Alu	Copper, brass, tin	Plastics GRP/CRP	Hardox 400, 450
< 1100 N	< 900 N		> 10% Si			



☒ Sonderpreis / Sale Artikel. Lieferbar solange Vorrat.
Special price / sale article. While stocks last.

Art.	Ø mm	Ø Zoll Inch	Art.	Ø mm	Ø Zoll Inch	Art.	Ø mm	Ø Zoll Inch	Art.	Ø mm	Ø Zoll Inch
20 1185N 018	18	45/64"	20 1185N 024	24	15/16"	20 1185N 030	30	1.3/16"	20 1185N 040	40	1.37/64"
20 1185N 019	19	3/4"	20 1185N 025	25	63/64"	20 1185N 032	32	1.17/64"	20 1185N 045	45	1.49/64"
20 1185N 020	20	25/32"	20 1185N 026	26	1.1/32"	20 1185N 033	33	1.19/64"	20 1185N 050	50	1.31/32"
20 1185N 021	21	53/64"	20 1185N 027	27	1.1/16"	20 1185N 035	35	1.3/8"			
20 1185N 022	22	55/64"	20 1185N 028	28	1.7/64"	20 1185N 036	36	1.27/64"			
20 1185N 023	23	29/32"	20 1185N 029	29	1.9/64"	20 1185N 038	38	1.1/2"			

Größere Ø siehe Art. 20 1650 Seite 386 sowie Art. 20 1660 Seite 388 – Ersatzartikel siehe Art. 20 1285N Seite 490, Art. 20 1650N Seite 458 ·
Achtung: Die Zollabmessungen entsprechen nicht exakt den mm Durchmessern.

Larger Ø see Art. 20 1650 page 386 and Art. 20 1660 page 388 – Replacement article see Art. 20 1285N page 490, Art. 20 1650N page 458 ·
Attention: The inch sizes do not correspond exactly to the mm diameters.

20 1185N

BLUE-DRILL LINE / 80

ZUBEHÖR • ACCESSORIES



AUSWERFERSTIFTE 1-TEILIG • EJECTOR PINS 1-PIECE

☒ 20 1439

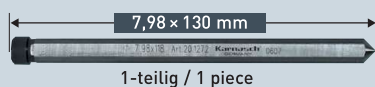

1-teilig / 1 piece

Packnorm 2 Stk. · Packaging unit 2 pcs.

Zusammen mit Aufnahmehalter 20 1842, 20 1291, 20 1843, 20 1845, 20 1846 (siehe Seite 542–543) kann dieser einteilige Auswerferstift verwendet werden. Es kann ohne Umstecken bis 110 mm Schnitttiefe in einem Arbeitsgang gebohrt werden. Robust und einfach.

It is possible to use this one-piece ejector pin in combination with tool holder article 20 1842, 20 1291, 20 1843, 20 1845, 20 1846 (see page 542–543). You can drill as deep as 110 mm in one working process without changing. Robust and easy.

AUSWERFERSTIFTE 2-TEILIG EJECTOR PINS 2-PIECE

☒ 20 1427



2-teilig / 2 piece

Packnorm 2 Stk. · Packaging unit 2 pcs.

ANWENDUNG AUSWERFERSTIFTE 2-TEILIG APPLICATION EJECTOR PINS 2-PIECE



Anwendung:

Teil 1 in den Schaft des Kernbohrers einführen. Teil 2 auf Teil 1 schieben. Bohren Sie bis ca. 50 mm Schnitttiefe. Danach Teil 2 entfernen und weiter bohren.

Application:

Insert piece 1 into the annular cutter shank. Push piece 2 onto part 1. Drill as deep as 50 mm cutting depth. Then remove piece 2 and continue drilling.

☒ **Warum 2-teilige Auswerferstifte?** In der Regel haben Standard Morsekonus-Aufnahmehalter eine Schnitttiefenkapazität von 50 mm. Wenn **keine extra langen** Aufnahmehalter verwendet werden (wie auf Seite 542–543 Art. 20 1842, 20 1291, 20 1843, 20 1845, 20 1846), müssen bei Schnitttiefen über 50 mm 2-teilige Auswerferstifte verwendet werden.

☒ **Why use 2-part ejector pins?** Usually, standard morse taper holders have a cutting depth capacity of 50 mm. If **no extra-long** holders are used (e.g. as on page 542–543 Art. 20 1842, 20 1291, 20 1843, 20 1845, 20 1846), you need for drill depths above 50 mm 2-part ejector pins.

Schnittdaten
Cutting data

Film
Movie



1488



Zubehör für HSS-XE + DURABLUe-beschichteten Kernbohrer, Nitto/Universalschaft, Nutzlänge 80 mm
 Accessories for HSS-XE + DURABLUe-coated annular cutter, Nitto/Universal shank, drill depth 80 mm | 3"

BLUE-DRILL LINE / 80

20 1185N

**ADAPTER + PASSENDE AUSWERFERSTIFTE
 ADAPTER + SUITABLE EJECTOR PINS**

FEIN Quick-In 18 mm
 Weldon + Nitto/Universal 19 mm 3/4"

• 20 1161

7,98 x 157 mm
 1 2-teilig / 2 piece 2

• 20 1436

Packnorm 2 Stk. · Packaging unit 2 pcs.

Weldon 32 mm 1.1/4"
 Weldon + Nitto/Universal 19 mm 3/4"

• 21 0048

7,98 x 130 mm
 1-teilig / 1 piece

• 20 1439

Packnorm 2 Stk. · Packaging unit 2 pcs.

7,98 x 130 mm
 1 2-teilig / 2 piece 2

• 20 1427

Packnorm 2 Stk. · Packaging unit 2 pcs.

Ersatz-Innensechskantschrauben für alle Adapter siehe Seite 550
 Spare allen screws for all adapters see page 550

ZUBEHÖR · SETS · DISPLAYS · ERSATZTEILE / ACCESSORIES · SETS · DISPLAYS · SPARE PARTS

Aufnahmehalter mit Morsekonus 2 / 3 / 4 / 5 und Reduzierhülsen 541-543
 Tool holders with morse taper 2 / 3 / 4 / 5 and reduction sleeves



Kühlmittel-Druckflaschen 548
 Coolant pressure bottles



Kegelsenker mit Weldonchaft 544/545
 Countersinks with Weldon shank

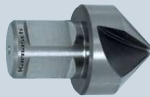

Magnetstab zur Entfernung der Bohrspäne 549
 Magnetic stick for chip removal



Spiralbohradapter Weldon + Spiralbohrer Ø 2,5-12 mm 648
 Twist drill adaptors Weldon + twist drills Ø 2,5-12 mm



Sets · Displays 553-582
 Sets · Displays



Gewindeadapter Weldon + Gewindebohrer M 3 - M 30 649-650
 Tapping adapter Weldon + taps M 3 - M 30



Adapter + passende Bohrfutter 548
 Adapters + suitable drill chucks

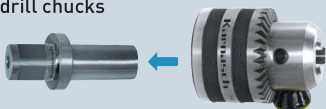

Ersatzteile 550-552
 Spare parts

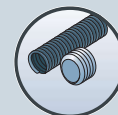

- 1
- 2
- 3
- 4
- 5
- 6
- 7
- 8
- 9
- 10

20 1180N

BLUE-DRILL LINE / 110

HSS-XE + DURABLUe-beschichteter Kernbohrer, Nitto/Universalschaft, Nutzlänge 110 mm
HSS-XE + DURABLUe-coated annular cutter, Nitto/Universal shank, drill depth 110 mm | 4"



ANWENDUNG • APPLICATION

Stahl	Edelstahl	Grauguss	Alu	Kupfer, Messing, Zinn	Kunststoffe GFK/CFK	Hardox 400, 450
Steel	Stainless	Grey cast iron	Alu	Copper, brass, tin	Plastics GRP/CRP	Hardox 400, 450
< 1100 N	< 900 N		> 10% Si			



☞ Sonderpreis / Sale Artikel. Lieferbar solange Vorrat.
Special price / sale article. While stocks last.

Art.	Ø mm	Ø Zoll Inch	Art.	Ø mm	Ø Zoll Inch	Art.	Ø mm	Ø Zoll Inch	Art.	Ø mm	Ø Zoll Inch
20 1180N 018	18	45/64"	20 1180N 024	24	15/16"	20 1180N 030	30	1.3/16"	20 1180N 040	40	1.37/64"
20 1180N 019	19	3/4"	20 1180N 025	25	63/64"	20 1180N 032	32	1.17/64"	20 1180N 045	45	1.49/64"
20 1180N 020	20	25/32"	20 1180N 026	26	1.1/32"	20 1180N 033	33	1.19/64"	20 1180N 050	50	1.31/32"
20 1180N 021	21	53/64"	20 1180N 027	27	1.1/16"	20 1180N 035	35	1.3/8"			
20 1180N 022	22	55/64"	20 1180N 028	28	1.7/64"	20 1180N 036	36	1.27/64"			
20 1180N 023	23	29/32"	20 1180N 029	29	1.9/64"	20 1180N 038	38	1.1/2"			

Ersatzartikel siehe Art. 20 1280N Seite 492, Art. 20 1660N Seite 460 · **Achtung:** Die Zollabmessungen entsprechen nicht exakt den mm Durchmessern.
Replacement article see Art. 20 1280N page 492, Art. 20 1660N page 460 · **Attention:** The inch sizes do not correspond exactly to the mm diameters.

20 1180N

BLUE-DRILL LINE / 110

ZUBEHÖR • ACCESSORIES



AUSWERFERSTIFTE 1-TEILIG • EJECTOR PINS 1-PIECE

☞ 20 1399



1-teilig / 1 piece

Packnorm 2 Stk. · Packaging unit 2 pcs.

Zusammen mit Aufnahmehalter 20 1842, 20 1291, 20 1843, 20 1845, 20 1846 (siehe Seite 542–543) kann dieser einteilige Auswerferstift verwendet werden. Es kann ohne Umstecken bis 110 mm Schnitttiefe in einem Arbeitsgang gebohrt werden. Robust und einfach.

It is possible to use this one-piece ejector pin in combination with tool holder article 20 1842, 20 1291, 20 1843, 20 1845, 20 1846 (see page 542–543). You can drill as deep as 110 mm in one working process without changing. Robust and easy.

AUSWERFERSTIFTE 2-TEILIG EJECTOR PINS 2-PIECE

☞ 20 1428

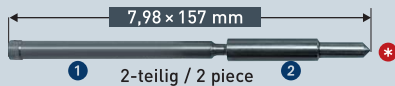

2-teilig / 2 piece

Packnorm 2 Stk. · Packaging unit 2 pcs.

ANWENDUNG AUSWERFERSTIFTE 2-TEILIG APPLICATION EJECTOR PINS 2-PIECE



Anwendung:

Teil 1 in den Schaft des Kernbohrers einführen. Teil 2 auf Teil 1 schieben. Bohren Sie bis ca. 50 mm Schnitttiefe. Danach Teil 2 entfernen und weiter bohren.

Application:

Insert piece 1 into the annular cutter shank. Push piece 2 onto part 1. Drill as deep as 50 mm cutting depth. Then remove piece 2 and continue drilling.

☞ **Warum 2-teilige Auswerferstifte?** In der Regel haben Standard Morsekonus-Aufnahmehalter eine Schnitttiefenkapazität von 50 mm. Wenn **keine extra langen** Aufnahmehalter verwendet werden (wie auf Seite 542–543 Art. 20 1842, 20 1291, 20 1843, 20 1845, 20 1846), müssen bei Schnitttiefen über 50 mm 2-teilige Auswerferstifte verwendet werden.

☞ **Why use 2-part ejector pins?** Usually, standard morse taper holders have a cutting depth capacity of 50 mm. If **no extra-long** holders are used (e.g. as on page 542–543 Art. 20 1842, 20 1291, 20 1843, 20 1845, 20 1846), you need for drill depths above 50 mm 2-part ejector pins.

Schnittdaten
Cutting data

Film
Movie



1488



Zubehör für HSS-XE + DURABLU- beschichteten Kernbohrer, Nitto/Universalschaft, Nutzlänge 110 mm
 Accessories for HSS-XE + DURABLU-coated annular cutter, Nitto/Universal shank, drill depth 110 mm | 4"

BLUE-DRILL LINE 110

20 1180N

ADAPTER + PASSENDE AUSWERFERSTIFTE
ADAPTER + SUITABLE EJECTOR PINS



• 20 1161

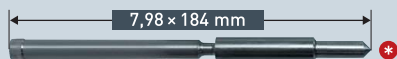

• 20 1438

1 2-teilig / 2 piece 2

Packnorm 2 Stk. · Packaging unit 2 pcs.



• 21 0048



• 20 1399

1-teilig / 1 piece

Packnorm 2 Stk. · Packaging unit 2 pcs.

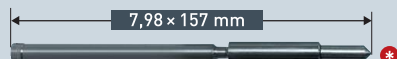

• 20 1428

1 2-teilig / 2 piece 2

Packnorm 2 Stk. · Packaging unit 2 pcs.

Ersatz-Innensechskantschrauben für alle Adapter siehe Seite 550
 Spare allen screws for all adapters see page 550

ZUBEHÖR · SETS · DISPLAYS · ERSATZTEILE / ACCESSORIES · SETS · DISPLAYS · SPARE PARTS

Aufnahmehalter mit Morsekonus 2 / 3 / 4 / 5 und Reduzierhülsen  541-543
 Tool holders with morse taper 2 / 3 / 4 / 5 and reduction sleeves



Kühlmittel-Druckflaschen  548
 Coolant pressure bottles



Kegelsenker mit Weldonchaft  544/545
 Countersinks with Weldon shank

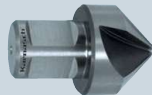

Magnetstab zur Entfernung der Bohrspäne  549
 Magnetic stick for chip removal



Spiralbohradapter Weldon + Spiralbohrer Ø 2,5-12 mm  648
 Twist drill adaptors Weldon + twist drills Ø 2,5-12 mm



Sets · Displays  553-582
 Sets · Displays



Gewindeadapter Weldon + Gewindebohrer M 3 - M 30  649-650
 Tapping adapter Weldon + taps M 3 - M 30



Adapter + passende Bohrfutter  548
 Adapters + suitable drill chucks

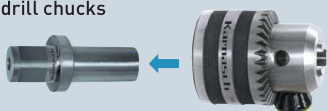

Ersatzteile  550-552
 Spare parts

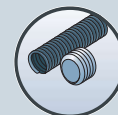

20 1611

BLUE-DRILL LINE 30
ZOLL / INCH

HSS-XE + DURABLU-beschichteter Kernbohrer, Nitto/Universalschaft, Nutzlänge 30 mm
HSS-XE + DURABLU-coated annular cutter, Nitto/Universal shank, drill depth 30 mm | 1"



ANWENDUNG • APPLICATION

Stahl	Edelstahl	Grauguss	Alu	Kupfer, Messing, Zinn	Kunststoffe GFK/CFK	Hardox 400, 450
Steel	Stainless	Grey cast iron	Alu	Copper, brass, tin	Plastics GRP/CRP	Hardox 400, 450
< 1100 N	< 900 N		> 10% Si			

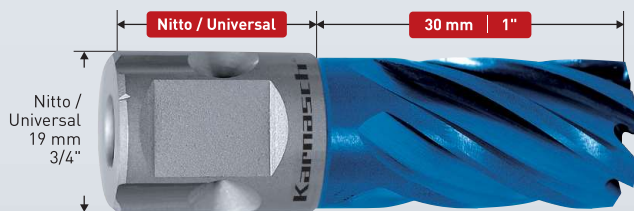

Zoll/Inch	Ø mm	Art.	Zoll/Inch	Ø mm	Art.	Zoll/Inch	Ø mm	Art.	Zoll/Inch	Ø mm	Art.
• 7/16"	11,10	20 1611 005	• 15/16"	23,81	20 1611 045	• 1.7/16"	36,51	20 1611 085	• 1.15/16"	49,21	20 1611 125
• 1/2"	12,70	20 1611 010	• 1"	25,40	20 1611 050	• 1.1/2"	38,10	20 1611 090	• 2"	50,80	20 1611 130
• 9/16"	14,28	20 1611 015	• 1.1/16"	26,98	20 1611 055	• 1.9/16"	39,68	20 1611 095	• 2.1/16"	52,38	20 1611 135
• 5/8"	15,87	20 1611 020	• 1.1/8"	28,57	20 1611 060	• 1.5/8"	41,27	20 1611 100			
• 11/16"	17,46	20 1611 025	• 1.3/16"	30,13	20 1611 065	• 1.11/16"	42,86	20 1611 105			
• 3/4"	19,04	20 1611 030	• 1.1/4"	31,75	20 1611 070	• 1.3/4"	44,45	20 1611 110			
• 13/16"	20,63	20 1611 035	• 1.5/16"	33,33	20 1611 075	• 1.13/16"	46,03	20 1611 115			
• 7/8"	22,22	20 1611 040	• 1.3/8"	34,92	20 1611 080	• 1.7/8"	47,62	20 1611 120			

Ersatzartikel siehe Art. 20 1610 Seite 494, Art. 20 1630 Seite 462 -
Achtung: Die Zollabmessungen entsprechen nicht exakt den mm Durchmessern.
Replacement article see Art. 20 1610 page 494, Art. 20 1630 page 462 -
Attention: The inch sizes do not correspond exactly to the mm diameters.

20 1611

BLUE-DRILL LINE 30
ZOLL / INCH

ZUBEHÖR • ACCESSORIES



AUSWERFERSTIFTE • EJECTOR PINS



Packnorm 2 Stk. · Packaging unit 2 pcs.

Ø 7/16" • 20 1482



Packnorm 2 Stk. · Packaging unit 2 pcs.

Ø 1/2" - 2.1/16" • 20 1261

20 1611

BLUE-DRILL LINE 30
ZOLL / INCH

SETS / DISPLAYS Seite / Page 574



Wir bieten eine große Auswahl an Sets / Displays – Inhaltsvorschläge 20 1611 BLUE-DRILL LINE30 – siehe Seite 574. Anderer Inhalt auf Wunsch möglich, durch individuell bestückbare Sets / Displays.
We offer a large selection of sets / displays – recommended content 20 1611 BLUE-DRILL LINE30 – see page 574. Other content possible by individually equipped sets / displays.



Schnittdaten
Cutting data

Film
Movie



1488

- 1
- 2
- 3
- 4
- 5
- 6
- 7
- 8
- 9
- 10

Zubehör für HSS-XE + DURABLU-beschichteten Kernbohrer, Nitto/Universalschaft, Nutzlänge 30 mm
 Accessories for HSS-XE + DURABLU-coated annular cutter, Nitto/Universal shank, drill depth 30 mm | 1"

BLUE-DRILL LINE 30 20 1611
ZOLL / INCH

ADAPTER + PASSENDE AUSWERFERSTIFTE
ADAPTER + SUITABLE EJECTOR PINS

 FEIN Quick-In 18 mm
 Weldon + Nitto/Universal 19 mm 3/4"
 • 20 1263

 6,34 x 102 mm
 • 20 1271

Packnorm 2 Stk. · Packaging unit 2 pcs.

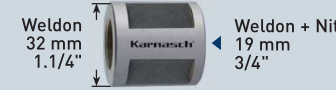
 Weldon 32 mm 1.1/4"
 Weldon + Nitto/Universal 19 mm 3/4"
 • 21 0048

 4,74 x 77 mm
 • 20 1482

Packnorm 2 Stk. · Packaging unit 2 pcs.

 6,34 x 77 mm
 • 20 1261

Packnorm 2 Stk. · Packaging unit 2 pcs.

Ersatz-Innensechskantschrauben für alle Adapter siehe Seite 550
 Spare allen screws for all adapters see page 550

VERLÄNGERUNGEN + PASSENDE AUSWERFERSTIFTE
EXTENSIONS + SUITABLE EJECTOR PINS

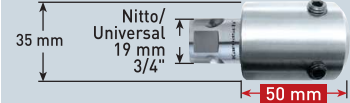
 Nitto/Universal 19 mm 3/4"
 Weldon + Nitto/Universal 19 mm 3/4"
 50 mm
 • 20 1406

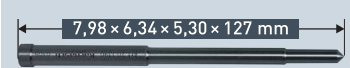
 7,98 x 6,34 x 5,30 x 127 mm
 • 20 1433

Packnorm 2 Stk. · Packaging unit 2 pcs.

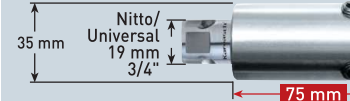
 Nitto/Universal 19 mm 3/4"
 Weldon + Nitto/Universal 19 mm 3/4"
 75 mm
 • 20 1407

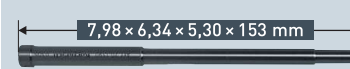
 7,98 x 6,34 x 5,30 x 153 mm
 • 20 1396

Packnorm 2 Stk. · Packaging unit 2 pcs.

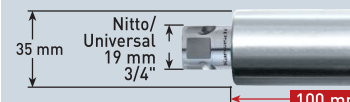
 Nitto/Universal 19 mm 3/4"
 Weldon + Nitto/Universal 19 mm 3/4"
 100 mm
 • 20 1409

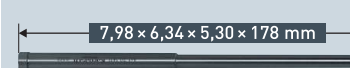
 7,98 x 6,34 x 5,30 x 178 mm
 • 20 1411

Packnorm 2 Stk. · Packaging unit 2 pcs.

Ersatz-Innensechskantschrauben für alle Verlängerungen siehe Seite 550
 Spare allen screws for all extensions see page 550

ZUBEHÖR • SETS • DISPLAYS • ERSATZTEILE / ACCESSORIES • SETS • DISPLAYS • SPARE PARTS

Aufnahmehalter mit Morsekonus 2 / 3 / 4 / 5 und Reduzierhülsen
 Tool holders with morse taper 2 / 3 / 4 / 5 and reduction sleeves
 541-543



Kühlmittel-Druckflaschen
 Coolant pressure bottles
 548



Kegelsenker mit Weldonschaft
 Countersinks with Weldon shank
 544/545



Magnetstab zur Entfernung der Bohrspäne
 Magnetic stick for chip removal
 549



Spiralbohradapter Weldon + Spiralbohrer Ø 2,5-12 mm
 Twist drill adaptors Weldon + twist drills Ø 2,5-12 mm
 648



Sets · Displays
 Sets · Displays
 553-582



Gewindeadapter Weldon + Gewindebohrer M 3 - M 30
 Tapping adapter Weldon + taps M 3 - M 30
 649-650



Adapter + passende Bohrfutter
 Adapters + suitable drill chucks
 548

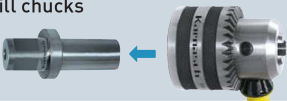

Ersatzteile
 Spare parts
 550-552



- 1 
- 2 
- 3 
- 4 
- 5 
- 6 
- 7 
- 8 
- 9 
- 10 

20 1621

BLUE-DRILL LINE
ZOLL / INCH 55

HSS-XE + DURABLUe-beschichteter Kernbohrer, Nitto/Universalschaft, Nutzlänge 55 mm
HSS-XE + DURABLUe-coated annular cutter, Nitto/Universal shank, drill depth 55 mm | 2"



ANWENDUNG • APPLICATION

Stahl Steel	Edelstahl Stainless	Grauguss Grey cast iron	Alu Alu	Kupfer, Messing, Zinn Copper, brass, tin	Kunststoffe GFK/CFK Plastics GRP/CRP	Hardox 400, 450
< 1100 N	< 900 N		> 10% Si			

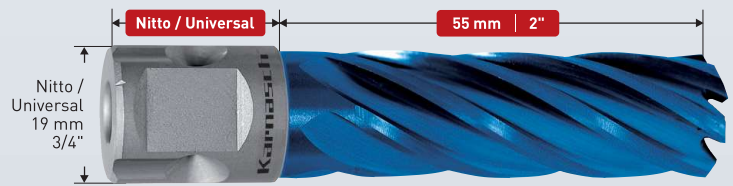

☒ Sonderpreis / Sale Artikel. Lieferbar solange Vorrat.
Special price / sale article. While stocks last.

Zoll/Inch	Ø mm	Art.	Zoll/Inch	Ø mm	Art.	Zoll/Inch	Ø mm	Art.
7/16"	11,10	20 1621 005	1.1/16"	26,98	20 1621 055	1.11/16"	42,86	20 1621 105
1/2"	12,70	20 1621 010	1.1/8"	28,57	20 1621 060	1.3/4"	44,45	20 1621 110
9/16"	14,28	20 1621 015	1.3/16"	30,13	20 1621 065	1.13/16"	46,03	20 1621 115
5/8"	15,87	20 1621 020	1.1/4"	31,75	20 1621 070	1.7/8"	47,62	20 1621 120
11/16"	17,46	20 1621 025	1.5/16"	33,33	20 1621 075	1.15/16"	49,21	20 1621 125
3/4"	19,04	20 1621 030	1.3/8"	34,92	20 1621 080	2"	50,80	20 1621 130
13/16"	20,63	20 1621 035	1.7/16"	36,51	20 1621 085	2.1/16"	52,38	20 1621 135
7/8"	22,22	20 1621 040	1.1/2"	38,10	20 1621 090			
15/16"	23,81	20 1621 045	1.9/16"	39,68	20 1621 095			
1"	25,40	20 1621 050	1.5/8"	41,27	20 1621 100			

Zoll/Inch	Ø mm	Art.
1"	25,40	20 1621w 050
1.7/8"	47,62	20 1621w 120

Ersatzartikel siehe Art. 20 1620 Seite 496, Art. 20 1640 Seite 464.
Achtung: Die Zollabmessungen entsprechen nicht exakt den mm Durchmessern.
Replacement article see Art. 20 1620 page 496, Art. 20 1640 page 464.
Attention: The inch sizes do not correspond exactly to the mm diameters.



* In Weldonschaft Sonderpreise solange Vorrat reicht
* Special prices as long as supplies are available in Weldon shank

20 1621

BLUE-DRILL LINE
ZOLL / INCH 55

ZUBEHÖR • ACCESSORIES

AUSWERFERSTIFTE • EJECTOR PINS



☒ Ø 7/16" • 20 1485

Packnorm 2 Stk. · Packaging unit 2 pcs.



☒ Ø 1/2" - 2.1/16" • 20 1271

Packnorm 2 Stk. · Packaging unit 2 pcs.

Schnittdaten
Cutting data

Film
Movie



1488



Zubehör für HSS-XE + DURABLU- beschichteten Kernbohrer, Nitto/Universalschaft, Nutzlänge 55 mm
 Accessories for HSS-XE + DURABLU-coated annular cutter, Nitto/Universal shank, drill depth 55 mm | 2"

BLUE-DRILL LINE 55 ZOLL / INCH **20 1621**

ADAPTER + PASSENDE AUSWERFERSTIFTE
ADAPTER + SUITABLE EJECTOR PINS

 FEIN Quick-In 18 mm
 Weldon + Nitto/Universal 19 mm 3/4"
 • 20 1263

 6,34 x 130 mm
 • 20 1160

Packnorm 2 Stk. · Packaging unit 2 pcs.

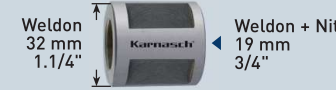
 Weldon 32 mm 1.1/4"
 Weldon + Nitto/Universal 19 mm 3/4"
 • 21 0048

 4,74 x 102 mm
 Ø 7/16" • 20 1485

Packnorm 2 Stk. · Packaging unit 2 pcs.

 6,34 x 102 mm
 Ø 1/2" - 2.1/16" • 20 1271

Packnorm 2 Stk. · Packaging unit 2 pcs.

Ersatz-Innensechskantschrauben für alle Adapter siehe Seite 550
 Spare allen screws for all adapters see page 550

VERLÄNGERUNGEN + PASSENDE AUSWERFERSTIFTE
EXTENSIONS + SUITABLE EJECTOR PINS

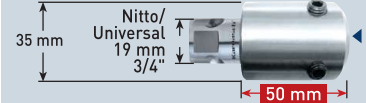
 Nitto/Universal 19 mm 3/4"
 Weldon + Nitto/Universal 19 mm 3/4"
 50 mm
 • 20 1406

 7,98 x 6,34 x 5,30 x 153 mm
 • 20 1396

Packnorm 2 Stk. · Packaging unit 2 pcs.

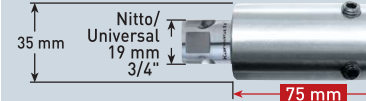
 Nitto/Universal 19 mm 3/4"
 Weldon + Nitto/Universal 19 mm 3/4"
 75 mm
 • 20 1407

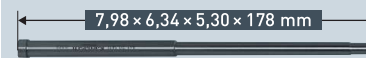
 7,98 x 6,34 x 5,30 x 178 mm
 • 20 1411

Packnorm 2 Stk. · Packaging unit 2 pcs.

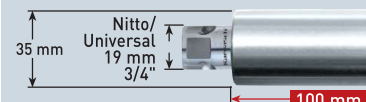
 Nitto/Universal 19 mm 3/4"
 Weldon + Nitto/Universal 19 mm 3/4"
 100 mm
 • 20 1409

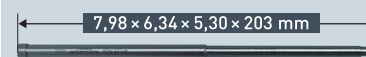
 7,98 x 6,34 x 5,30 x 203 mm
 • 20 1426

Packnorm 2 Stk. · Packaging unit 2 pcs.

Ersatz-Innensechskantschrauben für alle Verlängerungen siehe Seite 550
 Spare allen screws for all extensions see page 550

ZUBEHÖR • SETS • DISPLAYS • ERSATZTEILE / ACCESSORIES • SETS • DISPLAYS • SPARE PARTS

Aufnahmehalter mit Morsekonus 2 / 3 / 4 / 5 und Reduzierhülsen  541-543
 Tool holders with morse taper 2 / 3 / 4 / 5 and reduction sleeves

Kühlmittel-Druckflaschen  548
 Coolant pressure bottles

Kegelsenker mit Weldonschaft  544/545
 Countersinks with Weldon shank

Magnetstab zur Entfernung der Bohrspäne  549
 Magnetic stick for chip removal

Spiralbohradapter Weldon + Spiralbohrer Ø 2,5-12 mm  648
 Twist drill adaptors Weldon + twist drills Ø 2,5-12 mm

Sets · Displays  553-582
 Sets · Displays

Gewindeadapter Weldon + Gewindebohrer M 3 - M 30  649-650
 Tapping adapter Weldon + taps M 3 - M 30

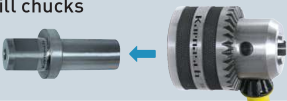
Adapter + passende Bohrfutter  548
 Adapters + suitable drill chucks

Ersatzteile  550-552
 Spare parts

- 1 
- 2 
- 3 
- 4 
- 5 
- 6 
- 7 
- 8 
- 9 
- 10 

20 1125

BLUE-DRILL LINE
ZOLL / INCH 80

HSS-XE + DURABLU- beschichteter Kernbohrer, Nitto/Universalschaft, Nutzlänge 80 mm
HSS-XE + DURABLU-coated annular cutter, Nitto/Universal shank, drill depth 80 mm | 3"



ANWENDUNG • APPLICATION

Stahl	Edelstahl	Grauguss	Alu	Kupfer, Messing, Zinn	Kunststoffe GFK/CFK	Hardox 400, 450
Steel	Stainless	Grey cast iron	Alu	Copper, brass, tin	Plastics GRP/CRP	Hardox 400, 450
< 1100 N	< 900 N		> 10% Si			



☞ Sonderpreis / Sale Artikel. Lieferbar solange Vorrat.
Special price / sale article. While stocks last.

Zoll/Inch	Ø mm	Art.	Zoll/Inch	Ø mm	Art.	Zoll/Inch	Ø mm	Art.	Zoll/Inch	Ø mm	Art.
% 11/16"	17,46	20 1125 025	% 1.1/16"	26,98	20 1125 055	% 1.7/16"	36,51	20 1125 085	% 1.13/16"	46,03	20 1125 115
% 3/4"	19,04	20 1125 030	% 1.1/8"	28,57	20 1125 060	% 1.1/2"	38,10	20 1125 090	% 1.7/8"	47,62	20 1125 120
% 13/16"	20,63	20 1125 035	% 1.3/16"	30,13	20 1125 065	% 1.9/16"	39,68	20 1125 095	% 1.15/16"	49,21	20 1125 125
% 7/8"	22,22	20 1125 040	% 1.1/4"	31,75	20 1125 070	% 1.5/8"	41,27	20 1125 100	% 2"	50,80	20 1125 130
% 15/16"	23,81	20 1125 045	% 1.5/16"	33,33	20 1125 075	% 1.11/16"	42,86	20 1125 105	% 2.1/16"	52,38	20 1125 135
% 1"	25,40	20 1125 050	% 1.3/8"	34,92	20 1125 080	% 1.3/4"	44,45	20 1125 110			

Ersatzartikel siehe Art. 20 1670 Seite 466, Art. 20 1285N Seite 490 ·
Achtung: Die Zollabmessungen entsprechen nicht exakt den mm Durchmessern.
Replacement article see Art. 20 1670 page 466, Art. 20 1285N page 490 ·
Attention: The inch sizes do not correspond exactly to the mm diameters.

20 1125

BLUE-DRILL LINE
ZOLL / INCH 80

ZUBEHÖR • ACCESSORIES



AUSWERFERSTIFTE 1-TEILIG • EJECTOR PINS 1-PIECE

☞ 20 1439



1-teilig / 1 piece

Packnorm 2 Stk. · Packaging unit 2 pcs.

Zusammen mit Aufnahmehalter 20 1842, 20 1291, 20 1843, 20 1845, 20 1846 (siehe Seite 542–543) kann dieser einteilige Auswerferstift verwendet werden. Es kann ohne Umstecken bis 110 mm Schnitttiefe in einem Arbeitsgang gebohrt werden. Robust und einfach.

It is possible to use this one-piece ejector pin in combination with tool holder article 20 1842, 20 1291, 20 1843, 20 1845, 20 1846 (see page 542–543). You can drill as deep as 110 mm in one working process without changing. Robust and easy.

AUSWERFERSTIFTE 2-TEILIG EJECTOR PINS 2-PIECE

☞ 20 1427



2-teilig / 2 piece

Packnorm 2 Stk. · Packaging unit 2 pcs.

ANWENDUNG AUSWERFERSTIFTE 2-TEILIG APPLICATION EJECTOR PINS 2-PIECE



Anwendung:

Teil 1 in den Schaft des Kernbohrers einführen. Teil 2 auf Teil 1 schieben. Bohren Sie bis ca. 50 mm Schnitttiefe. Danach Teil 2 entfernen und weiter bohren.

Application:

Insert piece 1 into the annular cutter shank. Push piece 2 onto part 1. Drill as deep as 50 mm cutting depth. Then remove piece 2 and continue drilling.

☞ **Warum 2-teilige Auswerferstifte?** In der Regel haben Standard Morsekonus-Aufnahmehalter eine Schnitttiefenkapazität von 50 mm. Wenn **keine extra langen** Aufnahmehalter verwendet werden (wie auf Seite 542–543 Art. 20 1842, 20 1291, 20 1843, 20 1845, 20 1846), müssen bei Schnitttiefen über 50 mm 2-teilige Auswerferstifte verwendet werden.

☞ **Why use 2-part ejector pins?** Usually, standard morse taper holders have a cutting depth capacity of 50 mm. If **no extra-long** holders are used (e.g. as on page 542–543 Art. 20 1842, 20 1291, 20 1843, 20 1845, 20 1846), you need for drill depths above 50 mm 2-part ejector pins.

Schnittdaten
Cutting data

Film
Movie



1488



- 1
- 2
- 3
- 4
- 5
- 6
- 7
- 8
- 9
- 10

Zubehör für HSS-XE + DURABLU- beschichteten Kernbohrer, Nitto/Universalschaft, Nutzlänge 80 mm
 Accessories for HSS-XE + DURABLU-coated annular cutter, Nitto/Universal shank, drill depth 80 mm | 3"

BLUE-DRILL LINE 80
 ZOLL / INCH

20 1125

ADAPTER + PASSENDE AUSWERFERSTIFTE
ADAPTER + SUITABLE EJECTOR PINS

FEIN Quick-In
 18 mm

Weldon + Nitto/Universal
 19 mm
 3/4"

• **20 1161**

7,98 × 157 mm

1 2-teilig / 2 piece 2

Packnorm 2 Stk. · Packaging unit 2 pcs.

Weldon
 32 mm
 1.1/4"

Weldon + Nitto/Universal
 19 mm
 3/4"

• **21 0048**

7,98 × 130 mm

1-teilig / 1 piece

Packnorm 2 Stk. · Packaging unit 2 pcs.

7,98 × 130 mm

1 2-teilig / 2 piece 2

Packnorm 2 Stk. · Packaging unit 2 pcs.

Ersatz-Innensechskantschrauben für alle Adapter siehe Seite 550
 Spare allen screws for all adapters see page 550

ZUBEHÖR · SETS · DISPLAYS · ERSATZTEILE / ACCESSORIES · SETS · DISPLAYS · SPARE PARTS

Aufnahmehalter mit Morsekonus 2 / 3 / 4 / 5 und Reduzierhülsen **541-543**
 Tool holders with morse taper 2 / 3 / 4 / 5 and reduction sleeves



Kühlmittel-Druckflaschen **548**
 Coolant pressure bottles



Kegelsenker mit Weldonchaft **544/545**
 Countersinks with Weldon shank



Magnetstab zur Entfernung der Bohrspäne **549**
 Magnetic stick for chip removal



Spiralbohradapter Weldon + Spiralbohrer Ø 2,5-12 mm **648**
 Twist drill adaptors Weldon + twist drills Ø 2,5-12 mm



Sets · Displays **553-582**
 Sets · Displays



Gewindeadapter Weldon + Gewindebohrer M 3 - M 30 **649-650**
 Tapping adapter Weldon + taps M 3 - M 30



Adapter + passende Bohrfutter **548**
 Adapters + suitable drill chucks

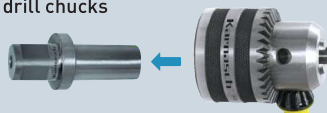

Ersatzteile **550-552**
 Spare parts

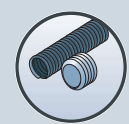

- 1 
- 2 
- 3 
- 4 
- 5 
- 6 
- 7 
- 8 
- 9 
- 10 **Index**

HSS-XE KERNBOHRER HSS-XE ANNULAR CUTTERS



GOLD-DRILL LINE

Karnasch GOLD-DRILL LINE Kernbohrer sind die am meisten verwendeten nicht beschichteten HSS-XE Kernbohrer.

Durch spezial GOLD-TECH Oberflächenbehandlung + Vollschliff + HSS-XE Spezialstahl hervorragend zum Bohren in Stähle bis 40 Rockwell (HRC) und sogar geeignet für Edelstähle.

Karnasch GOLD-DRILL LINE annular cutters are the most commonly used non-coated HSS-XE annular cutter.

With special surface treatment GOLD-TECH + FULLY GROUND + special steel HSS-XE are ideal for drilling in steel up to a strength of 40 Rockwell (HRC) and even suitable for stainless steels.

EIGENSCHAFTEN · PROPERTIES



Gefertigt aus hochlegiertem HSS-XE Spezialstahl. Für extreme Härte an den Zahnsitzen (bis 68 HRC). Somit hohe Verschleißfestigkeit und Standzeit.

Made of high-alloyed HSS-XE special steel. For extreme hardness at the tip of the tooth (up to 68 HRC). A high wear resistance and lifetime.



Gold-Tech Oberflächenbehandlung. Die Spezialbehandlung für höhere Standzeiten

Gold-Tech surface treatment. The special treatment for extended lifetimes.



Nur wenige Hersteller sind in der Lage in Stufen gehärtete Kernbohrer zu fertigen. Für uns ist dies „Standard“. Dadurch erreichen wir extrem harte Zahnsitzen (68 HRC) und dennoch einen flexiblen Kernbohrer.

Only few manufacturers are capable of producing step-hardened annular cutters. For Karnasch this is "standard". Only this makes us produce extremely hard tooth tips (68 HRC) and yet a flexible annular cutter.

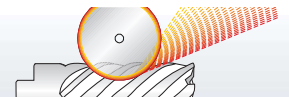

Aus dem vollen Material komplett geschliffen. Dieser Feinschliff erhöht die Zerspanleistung bei gleichzeitiger Reduzierung der Reibung. Für ein Mehr an Standzeit.

Completely made "FULLY GROUND". This refining increases the cutting ability while reducing friction at the same time. For an extended lifetime.

ANWENDUNG · APPLICATION

Stahl	Stahl	Stahl	Edelstahl	Alu	Alu	Kupfer, Messing, Zinn	Kunststoffe GFK/CFK	Hardox 400	Hardox 450
Steel	Steel	Steel	Stainless	Alu	Alu	Copper, brass, tin	Plastics GRP/CRP	Hardox 400	Hardox 450
< 750 N	< 900 N	< 1100 N	< 900 N	< 10% Si	> 10% Si				
✓	✓	✓	✓	✓	✓	✓	✓	✓	✓

✓ OPTIMAL · OPTIMAL ✓ GUT · GOOD ✓ MÖGLICH · POSSIBLE

HSS-XE KERNBOHRER

HSS-XE ANNULAR CUTTERS

Schnitttiefe · Drill depths	Ø mm	Ø Zoll / Inch	Art. / Type	
 Nitto / Universal 30 mm 1"	12-60	15/32-2.23/64"	20 1260N GOLD-DRILL LINE / 30	486
 Nitto / Universal 55 mm 2"	12-60	15/32-2.23/64"	20 1270N GOLD-DRILL LINE / 55	488
 Nitto / Universal 80 mm 3"	18-50	45/64-1.31/32"	20 1285N GOLD-DRILL LINE / 80	490
 Nitto / Universal 110 mm 4"	18-50	45/64-1.31/32"	20 1280N GOLD-DRILL LINE / 110	492
 Nitto / Universal 30 mm 1"	-	7/16-2.1/16"	20 1610 GOLD-DRILL LINE ZOLL / INCH / 30	494
 Nitto / Universal 55 mm 2"	-	7/16-2.1/16"	20 1620 GOLD-DRILL LINE ZOLL / INCH / 55	496
 Nitto / Universal 80 mm 3"	-	11/16-2.1/16"	20 1625 GOLD-DRILL LINE ZOLL / INCH / 80	498
 Nitto / Universal 110 mm 4"	-	11/16-2.1/16"	20 1635 GOLD-DRILL LINE / 110	500
 Nitto / Universal 30 mm 1"	14-32	9/16-1.1/16"	20 1240 GOLD-DRILL LINE SANDWICH / 30	502
 Nitto / Universal 55 mm 2"			20 1241 GOLD-DRILL LINE SANDWICH ZOLL / INCH / 30	
 Nitto / Universal 30 mm 1"	14-32	9/16-1.1/16"	20 1242 GOLD-DRILL LINE SANDWICH / 55	504
 Nitto / Universal 55 mm 2"			20 1243 GOLD-DRILL LINE SANDWICH ZOLL / INCH / 55	

Mehrschichtenbohrer. Spezialgeometrie zum Bohren übereinanderliegender Metallplatten bis 1100 N (Sandwich)

Multi layer drill. For stack drilling (sandwich) in steel up to 1100 N



ZUBEHÖR · ERSATZTEILE / ACCESSORIES · SPARE PARTS

Aufnahmehalter mit Morsekonus 2 / 3 / 4 / 5 und Reduzierhülsen Tool holders with morse taper 2 / 3 / 4 / 5 and reduction sleeves	 541-543	Gewintheadapter Weldon + Gewindebohrer M 3 - M 30 Tapping adapter Weldon + taps M 3 - M 30	 649-650
Kegelsenker mit Weldonchaft Countersinks with Weldon shank	 544/545	Adapter + passende Bohrfutter Adapters + suitable drill chucks	 548
Spiralbohradapter Weldon + Spiralbohrer Ø 2,5-12 mm Twist drill adaptors Weldon + twist drills Ø 2,5-12 mm	 648	Ersatzteile Spare parts	 550-552

1



2



3



4



5



6



7



8



9



10



Index

20 1260N

GOLD-DRILL LINE / 30

HSS-XE Kernbohrer, Nitto/Universalschaft, Nutzlänge 30 mm
HSS-XE annular cutter, Nitto/Universal shank, drill depth 30 mm | 1"



ANWENDUNG • APPLICATION

Stahl	Edelstahl	Grauguss	Alu	Kupfer, Messing, Zinn	Kunststoffe GFK/CFK	Hardox 400, 450
Steel	Stainless	Grey cast iron	Alu	Copper, brass, tin	Plastics GRP/CRP	Hardox 400, 450
< 900 N	< 900 N		< 10% Si			

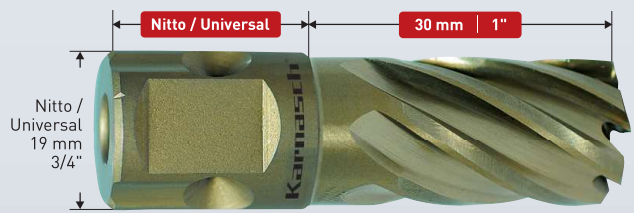

☒ Sonderpreis / Sale Artikel. Lieferbar solange Vorrat.
Special price / sale article. While stocks last.

Art.	Ø mm	Ø Zoll Inch	Art.	Ø mm	Ø Zoll Inch	Art.	Ø mm	Ø Zoll Inch	Art.	Ø mm	Ø Zoll Inch
20 1260N 012	• 12	15/32"	20 1260N 024	• 24	15/16"	20 1260N 038	• 38	1.1/2"	20 1260N 053	☒ 53	2.3/32"
20 1260N 013	• 13	33/64"	20 1260N 025	• 25	63/64"	20 1260N 039	• 39	1.17/32"	20 1260N 054	☒ 54	2.1/8"
20 1260N 0135	☒ 13,5	17/32"	20 1260N 026	• 26	1.1/32"	20 1260N 040	• 40	1.37/64"	20 1260N 055	• 55	2.11/64"
20 1260N 014	• 14	35/64"	20 1260N 027	• 27	1.1/16"	20 1260N 041	• 41	1.39/64"	20 1260N 056	☒ 56	2.13/64"
20 1260N 015	• 15	19/32"	20 1260N 028	• 28	1.7/64"	20 1260N 042	• 42	1.21/32"	20 1260N 057	☒ 57	2.1/4"
20 1260N 016	• 16	5/8"	20 1260N 029	• 29	1.9/64"	20 1260N 043	• 43	1.11/16"	20 1260N 059	☒ 59	2.21/64"
20 1260N 017	• 17	43/64"	20 1260N 030	• 30	1.3/16"	20 1260N 044	• 44	1.47/64"	20 1260N 060	• 60	2.23/64"
20 1260N 018	• 18	45/64"	20 1260N 031	• 31	1.7/32"	20 1260N 045	• 45	1.49/64"			
20 1260N 019	• 19	3/4"	20 1260N 032	• 32	1.17/64"	20 1260N 046	• 46	1.13/16"			
20 1260N 0195	☒ 19,5	49/64"	20 1260N 033	• 33	1.19/64"	20 1260N 047	• 47	1.27/32"			
20 1260N 020	• 20	25/32"	20 1260N 034	• 34	1.11/32"	20 1260N 048	• 48	1.57/64"			
20 1260N 021	• 21	53/64"	20 1260N 035	• 35	1.3/8"	20 1260N 049	• 49	1.59/64"			
20 1260N 022	• 22	55/64"	20 1260N 036	• 36	1.27/64"	20 1260N 050	• 50	1.31/32"			
20 1260N 023	• 23	29/32"	20 1260N 037	• 37	1.29/64"	20 1260N 052	☒ 52	2.3/64"			

Größere Ø bis 100 mm siehe Art. 20 1130A + Adapter Seite 595 / 597 .

Achtung: Die Zollabmessungen entsprechen nicht exakt den mm Durchmessern.

Larger Ø up to 100 mm see Art. 20 1130A + adapter page 595 / 597 .

Attention: The inch sizes do not correspond exactly to the mm diameters.

20 1260N

GOLD-DRILL LINE / 30

ZUBEHÖR • ACCESSORIES



AUSWERFERSTIFTE • EJECTOR PINS



☒ 20 1261

Packnorm 2 Stk. · Packaging unit 2 pcs.

20 1260N

GOLD-DRILL LINE / 30

SETS / DISPLAYS Seite / Page 575



Wir bieten eine große Auswahl an Sets / Displays – Inhaltsvorschläge 20 1260N GOLD-DRILL LINE30 – siehe Seite 575. Anderer Inhalt auf Wunsch möglich, durch individuell bestückbare Sets / Displays.

We offer a large selection of sets / displays – recommended content 20 1260N GOLD-DRILL LINE30 – see page 575. Other content possible by individually equipped sets / displays.



Schnittdaten
Cutting data

Film
Movie



1488

- 1
- 2
- 3
- 4
- 5
- 6
- 7
- 8
- 9
- 10

Zubehör für HSS-XE Kernbohrer, Nitto/Universalschaft, Nutzlänge 30 mm
 Accessories for HSS-XE annular cutter, Nitto/Universal shank, drill depth 30 mm | 1"

GOLD-DRILL LINE / 30

20 1260N

**ADAPTER + PASSENDE AUSWERFERSTIFTE
 ADAPTER + SUITABLE EJECTOR PINS**



• 20 1263



• 20 1271

Packnorm 2 Stk. · Packaging unit 2 pcs.



• 21 0048



• 20 1261

Packnorm 2 Stk. · Packaging unit 2 pcs.

Ersatz-Innensechskantschrauben für alle Adapter siehe Seite 550
 Spare allen screws for all adapters see page 550

**VERLÄNGERUNGEN + PASSENDE AUSWERFERSTIFTE
 EXTENSIONS + SUITABLE EJECTOR PINS**



• 20 1406

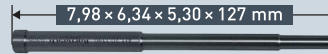

• 20 1433

Packnorm 2 Stk. · Packaging unit 2 pcs.

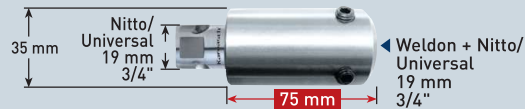

• 20 1407

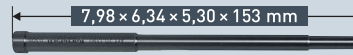

• 20 1396

Packnorm 2 Stk. · Packaging unit 2 pcs.



• 20 1409

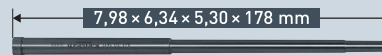

• 20 1411

Packnorm 2 Stk. · Packaging unit 2 pcs.

Ersatz-Innensechskantschrauben für alle Verlängerungen siehe Seite 550
 Spare allen screws for all extensions see page 550

ZUBEHÖR • SETS • DISPLAYS • ERSATZTEILE / ACCESSORIES • SETS • DISPLAYS • SPARE PARTS

Aufnahmehalter mit Morsekonus 2 / 3 / 4 / 5 und Reduzierhülsen
 Tool holders with morse taper 2 / 3 / 4 / 5 and reduction sleeves

☞ 541-543



Kühlmittel-Druckflaschen
 Coolant pressure bottles

☞ 548



Kegelsenker mit Weldonschaft
 Countersinks with Weldon shank

☞ 544/545

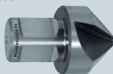

Magnetstab zur Entfernung der Bohrspäne
 Magnetic stick for chip removal

☞ 549



Spiralbohradapter Weldon + Spiralbohrer Ø 2,5-12 mm
 Twist drill adaptors Weldon + twist drills Ø 2,5-12 mm

☞ 648



Sets · Displays
 Sets · Displays

☞ 553-582



Gewindeadapter Weldon + Gewindebohrer M 3 - M 30
 Tapping adapter Weldon + taps M 3 - M 30

☞ 649-650



Adapter + passende Bohrfutter
 Adapters + suitable drill chucks

☞ 548

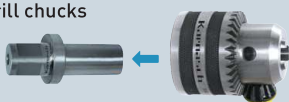

Ersatzteile
 Spare parts

☞ 550-552



20 1270N

GOLD-DRILL LINE / 55

HSS-XE Kernbohrer, Nitto/Universalschaft, Nutzlänge 55 mm
HSS-XE annular cutter, Nitto/Universal shank, drill depth 55 mm | 2"



ANWENDUNG • APPLICATION

Stahl	Edelstahl	Grauguss	Alu	Kupfer, Messing, Zinn	Kunststoffe GFK/CFK	Hardox 400, 450
Steel	Stainless	Grey cast iron	Alu	Copper, brass, tin	Plastics GRP/CRP	Hardox 400, 450
< 900 N	< 900 N		< 10% Si			

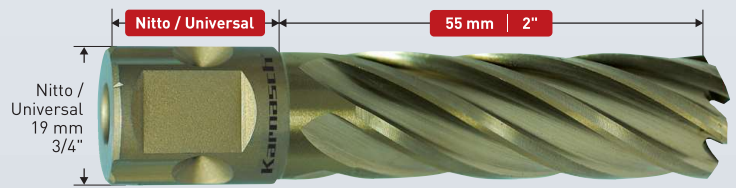

☞ Sonderpreis / Sale Artikel. Lieferbar solange Vorrat.
Special price / sale article. While stocks last.

Art.	Ø mm	Ø Zoll Inch	Art.	Ø mm	Ø Zoll Inch	Art.	Ø mm	Ø Zoll Inch	Art.	Ø mm	Ø Zoll Inch
20 1270N 012	• 12	15/32"	20 1270N 025	• 25	63/64"	20 1270N 039	• 39	1.17/32"	20 1270N 053	☞ 53	2.3/32"
20 1270N 013	• 13	33/64"	20 1270N 026	• 26	1.1/32"	20 1270N 040	• 40	1.37/64"	20 1270N 054	☞ 54	2.1/8"
20 1270N 014	• 14	35/64"	20 1270N 027	• 27	1.1/16"	20 1270N 041	• 41	1.39/64"	20 1270N 055	• 55	2.11/64"
20 1270N 015	• 15	19/32"	20 1270N 028	• 28	1.7/64"	20 1270N 042	• 42	1.21/32"	20 1270N 056	• 56	2.13/64"
20 1270N 0155	☞ 15,5	39/64"	20 1270N 029	• 29	1.9/64"	20 1270N 043	• 43	1.11/16"	20 1270N 057	• 57	2.1/4"
20 1270N 016	• 16	5/8"	20 1270N 030	• 30	1.3/16"	20 1270N 044	• 44	1.47/64"	20 1270N 058	☞ 58	2.9/32"
20 1270N 017	• 17	43/64"	20 1270N 031	• 31	1.7/32"	20 1270N 045	• 45	1.49/64"	20 1270N 059	☞ 59	2.21/64"
20 1270N 018	• 18	45/64"	20 1270N 032	• 32	1.17/64"	20 1270N 046	• 46	1.13/16"	20 1270N 060	• 60	2.23/64"
20 1270N 019	• 19	3/4"	20 1270N 033	• 33	1.19/64"	20 1270N 047	• 47	1.27/32"			
20 1270N 020	• 20	25/32"	20 1270N 034	• 34	1.11/32"	20 1270N 048	• 48	1.57/64"			
20 1270N 021	• 21	53/64"	20 1270N 035	• 35	1.3/8"	20 1270N 049	• 49	1.59/64"			
20 1270N 022	• 22	55/64"	20 1270N 036	• 36	1.27/64"	20 1270N 050	• 50	1.31/32"			
20 1270N 023	• 23	29/32"	20 1270N 037	☞ 37	1.29/64"	20 1270N 051	• 51	2.1/64"			
20 1270N 024	• 24	15/16"	20 1270N 038	• 38	1.1/2"	20 1270N 052	• 52	2.3/64"			

Größere Ø bis 100 mm siehe Art. 20 1141A + Adapter Seite 599 / 601.
Achtung: Die Zollabmessungen entsprechen nicht exakt den mm Durchmessern.
Larger Ø up to 100 mm see Art. 20 1141A + adapter page 599 / 601.
Attention: The inch sizes do not correspond exactly to the mm diameters.

20 1270N

GOLD-DRILL LINE / 55

ZUBEHÖR • ACCESSORIES



AUSWERFERSTIFTE • EJECTOR PINS



☞ 20 1271

Packnorm 2 Stk. • Packaging unit 2 pcs.

20 1270N

GOLD-DRILL LINE / 55

SETS / DISPLAYS Seite / Page 576



Wir bieten eine große Auswahl an Sets / Displays – Inhaltsvorschläge 20 1270N GOLD-DRILL LINE55 – siehe Seite 576. Anderer Inhalt auf Wunsch möglich, durch individuell bestückbare Sets / Displays.
We offer a large selection of sets / displays – recommended content 20 1270N GOLD-DRILL LINE55 – see page 576. Other content possible by individually equipped sets / displays.



Schnittdaten
Cutting data

Film
Movie



1488



Zubehör für HSS-XE Kernbohrer, Nitto/Universalschaft, Nutzlänge 55 mm
 Accessories for HSS-XE annular cutter, Nitto/Universal shank, drill depth 55 mm | 2"

GOLD-DRILL LINE / 55

20 1270N

**ADAPTER + PASSENDE AUSWERFERSTIFTE
 ADAPTER + SUITABLE EJECTOR PINS**



• **20 1263**



• **20 1160**

Packnorm 2 Stk. · Packaging unit 2 pcs.



• **21 0048**



• **20 1271**

Packnorm 2 Stk. · Packaging unit 2 pcs.

Ersatz-Innensechskantschrauben für alle Adapter siehe Seite 550
 Spare allen screws for all adapters see page 550

**VERLÄNGERUNGEN + PASSENDE AUSWERFERSTIFTE
 EXTENSIONS + SUITABLE EJECTOR PINS**

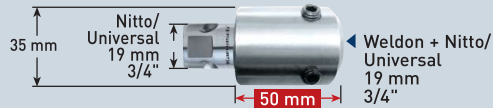

• **20 1406**

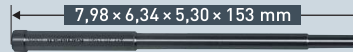

• **20 1396**

Packnorm 2 Stk. · Packaging unit 2 pcs.



• **20 1407**

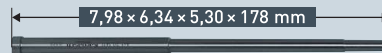

• **20 1411**

Packnorm 2 Stk. · Packaging unit 2 pcs.

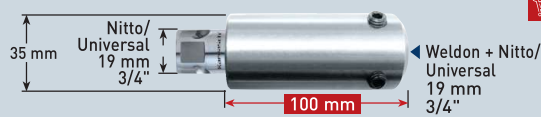

• **20 1409**

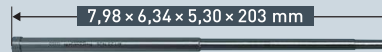

• **20 1426**

Packnorm 2 Stk. · Packaging unit 2 pcs.

Ersatz-Innensechskantschrauben für alle Verlängerungen siehe Seite 550
 Spare allen screws for all extensions see page 550

ZUBEHÖR • SETS • DISPLAYS • ERSATZTEILE / ACCESSORIES • SETS • DISPLAYS • SPARE PARTS

Aufnahmelhalter mit Morsekonus 2 / 3 / 4 / 5 und Reduzierhülsen  541-543
 Tool holders with morse taper 2 / 3 / 4 / 5 and reduction sleeves



Kühlmittel-Druckflaschen  548
 Coolant pressure bottles



Kegelsenker mit Weldonschaft  544/545
 Countersinks with Weldon shank

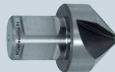

Magnetstab zur Entfernung der Bohrspäne  549
 Magnetic stick for chip removal



Spiralbohradapter Weldon + Spiralbohrer Ø 2,5-12 mm  648
 Twist drill adaptors Weldon + twist drills Ø 2,5-12 mm



Sets · Displays  553-582
 Sets · Displays



Gewindeadapter Weldon + Gewindebohrer M 3 - M 30  649-650
 Tapping adapter Weldon + taps M 3 - M 30



Adapter + passende Bohrfutter  548
 Adapters + suitable drill chucks

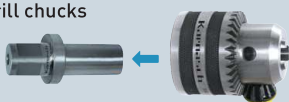

Ersatzteile  550-552
 Spare parts



20 1285N

GOLD-DRILL LINE / 80

HSS-XE Kernbohrer, Nitto/Universalschaft, Nutzlänge 80 mm

HSS-XE annular cutter, Nitto/Universal shank, drill depth 80 mm | 3"



ANWENDUNG • APPLICATION

Stahl	Edelstahl	Grauguss	Alu	Kupfer, Messing, Zinn	Kunststoffe GFK/CFK	Hardox 400, 450
Steel	Stainless	Grey cast iron	Alu	Copper, brass, tin	Plastics GRP/CRP	Hardox 400, 450
< 900 N	< 900 N		< 10% Si			

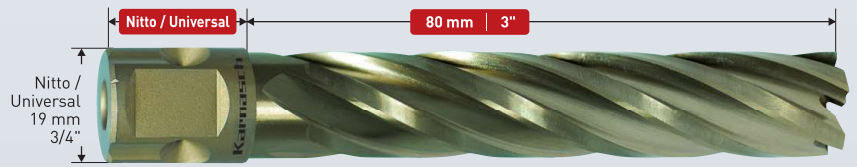

☞ Sonderpreis / Sale Artikel. Lieferbar solange Vorrat.
Special price / sale article. While stocks last.

Art.	Ø mm	Ø Zoll Inch	Art.	Ø mm	Ø Zoll Inch	Art.	Ø mm	Ø Zoll Inch	Art.	Ø mm	Ø Zoll Inch
20 1285N 018	• 18	45/64"	20 1285N 024	• 24	15/16"	20 1285N 030	• 30	1.3/16"	20 1285N 040	• 40	1.37/64"
20 1285N 019	• 19	3/4"	20 1285N 025	☞ 25	63/64"	20 1285N 032	• 32	1.17/64"	20 1285N 045	☞ 45	1.49/64"
20 1285N 020	• 20	25/32"	20 1285N 026	• 26	1.1/32"	20 1285N 033	☞ 33	1.19/64"	20 1285N 050	☞ 50	1.31/32"
20 1285N 021	☞ 21	53/64"	20 1285N 027	☞ 27	1.1/16"	20 1285N 035	• 35	1.3/8"			
20 1285N 022	• 22	55/64"	20 1285N 028	• 28	1.7/64"	20 1285N 036	☞ 36	1.27/64"			
20 1285N 023	☞ 23	29/32"	20 1285N 029	☞ 29	1.9/64"	20 1285N 038	☞ 38	1.1/2"			

Kleinere Ø ab 14 mm siehe Art. 20 1650N Seite 460 ·

Achtung: Die Zollabmessungen entsprechen nicht exakt den mm Durchmessern.

Smaller Ø from 14 mm see Art. 20 1650N page 460 ·

Attention: The inch sizes do not correspond exactly to the mm diameters.

20 1285N

GOLD-DRILL LINE / 80

ZUBEHÖR • ACCESSORIES



AUSWERFERSTIFTE 1-TEILIG • EJECTOR PINS 1-PIECE

☞ 20 1439



1-teilig / 1 piece

Packnorm 2 Stk. · Packaging unit 2 pcs.

Zusammen mit Aufnahmehalter 20 1842, 20 1291, 20 1843, 20 1845, 20 1846 (siehe Seite 542–543) kann dieser einteilige Auswerferstift verwendet werden. Es kann ohne Umstecken bis 110 mm Schnitttiefe in einem Arbeitsgang gebohrt werden. Robust und einfach.

It is possible to use this one-piece ejector pin in combination with tool holder article 20 1842, 20 1291, 20 1843, 20 1845, 20 1846 (see page 542–543). You can drill as deep as 110 mm in one working process without changing. Robust and easy.

AUSWERFERSTIFTE 2-TEILIG • EJECTOR PINS 2-PIECE

☞ 20 1427

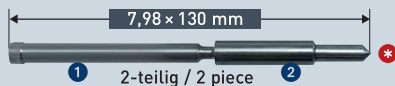

2-teilig / 2 piece

Packnorm 2 Stk. · Packaging unit 2 pcs.

ANWENDUNG AUSWERFERSTIFTE 2-TEILIG • APPLICATION EJECTOR PINS 2-PIECE



Anwendung:

Teil 1 in den Schaft des Kernbohrers einführen. Teil 2 auf Teil 1 schieben. Bohren Sie bis ca. 50 mm Schnitttiefe. Danach Teil 2 entfernen und weiter bohren.

Application:

Insert piece 1 into the annular cutter shank. Push piece 2 onto part 1. Drill as deep as 50 mm cutting depth. Then remove piece 2 and continue drilling.

☞ **Warum 2-teilige Auswerferstifte?** In der Regel haben Standard Morsekonus-Aufnahmehalter eine Schnitttiefenkapazität von 50 mm. Wenn **keine extra langen** Aufnahmehalter verwendet werden (wie auf Seite 542–543 Art. 20 1842, 20 1291, 20 1843, 20 1845, 20 1846), müssen bei Schnitttiefen über 50 mm 2-teilige Auswerferstifte verwendet werden.

☞ **Why use 2-part ejector pins?** Usually, standard morse taper holders have a cutting depth capacity of 50 mm. If **no extra-long** holders are used (e.g. as on page 542–543 Art. 20 1842, 20 1291, 20 1843, 20 1845, 20 1846), you need for drill depths above 50 mm 2-part ejector pins.

Schnittdaten
Cutting data

Film
Movie



1488



Index

Zubehör für HSS-XE Kernbohrer, Nitto/Universalschaft, Nutzlänge 80 mm
 Accessories for HSS-XE annular cutter, Nitto/Universal shank, drill depth 80 mm | 3"

GOLD-DRILL LINE / 80

20 1285N

ADAPTER + PASSENDE AUSWERFERSTIFTE
ADAPTER + SUITABLE EJECTOR PINS

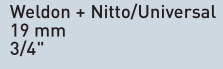
FEIN Quick-In 18 mm  **Weldon + Nitto/Universal 19 mm 3/4"** 

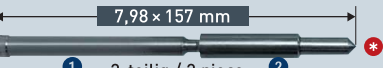
7,98 x 157 mm  **20 1161**

2-teilig / 2 piece

Packnorm 2 Stk. · Packaging unit 2 pcs.

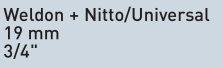
Weldon 32 mm 1.1/4"  **Weldon + Nitto/Universal 19 mm 3/4"** 

7,98 x 130 mm  **20 1436**

1-teilig / 1 piece

Packnorm 2 Stk. · Packaging unit 2 pcs.

7,98 x 130 mm  **20 1439**

2-teilig / 2 piece

Packnorm 2 Stk. · Packaging unit 2 pcs.

Ersatz-Innensechskantschrauben für alle Adapter siehe Seite 550
 Spare allen screws for all adapters see page 550

ZUBEHÖR · SETS · DISPLAYS · ERSATZTEILE / ACCESSORIES · SETS · DISPLAYS · SPARE PARTS

Aufnahmehalter mit Morsekonus 2 / 3 / 4 / 5 und Reduzierhülsen  **541-543**
 Tool holders with morse taper 2 / 3 / 4 / 5 and reduction sleeves

Kühlmittel-Druckflaschen  **548**
 Coolant pressure bottles

Kegelsenker mit Weldonchaft  **544/545**
 Countersinks with Weldon shank

Magnetstab zur Entfernung der Bohrspäne  **549**
 Magnetic stick for chip removal

Spiralbohradapter Weldon + Spiralbohrer Ø 2,5-12 mm  **648**
 Twist drill adaptors Weldon + twist drills Ø 2,5-12 mm

Sets · Displays  **553-582**
 Sets · Displays

Gewindeadapter Weldon + Gewindebohrer M 3 - M 30  **649-650**
 Tapping adapter Weldon + taps M 3 - M 30

Adapter + passende Bohrfutter  **548**
 Adapters + suitable drill chucks

Ersatzteile  **550-552**
 Spare parts

- 1 
- 2 
- 3 
- 4 
- 5 
- 6 
- 7 
- 8 
- 9 
- 10 **Index**

20 1280N

GOLD-DRILL LINE 110

HSS-XE Kernbohrer, Nitto/Universalschaft, Nutzlänge 110 mm
HSS-XE annular cutter, Nitto/Universal shank, drill depth 110 mm | 4"



ANWENDUNG • APPLICATION

Stahl	Edelstahl	Grauguss	Alu	Kupfer, Messing, Zinn	Kunststoffe GFK/CFK	Hardox 400, 450
Steel	Stainless	Grey cast iron	Alu	Copper, brass, tin	Plastics GRP/CRP	Hardox 400, 450
< 900 N	< 900 N		< 10% Si			



% Sonderpreis / Sale Artikel. Lieferbar solange Vorrat.
Special price / sale article. While stocks last.

Art.	Ø mm	Ø Zoll Inch	Art.	Ø mm	Ø Zoll Inch	Art.	Ø mm	Ø Zoll Inch	Art.	Ø mm	Ø Zoll Inch
20 1280N 018	• 18	45/64"	20 1280N 024	• 24	15/16"	20 1280N 030	• 30	1.3/16"	20 1280N 040	% 40	1.37/64"
20 1280N 019	• 19	3/4"	20 1280N 025	% 25	63/64"	20 1280N 032	% 32	1.17/64"	20 1280N 045	% 45	1.49/64"
20 1280N 020	• 20	25/32"	20 1280N 026	• 26	1.1/32"	20 1280N 033	% 33	1.19/64"	20 1280N 050	% 50	1.31/32"
20 1280N 021	• 21	53/64"	20 1280N 027	• 27	1.1/16"	20 1280N 035	% 35	1.3/8"			
20 1280N 022	• 22	55/64"	20 1280N 028	• 28	1.7/64"	20 1280N 036	• 36	1.27/64"			
20 1280N 023	% 23	29/32"	20 1280N 029	• 29	1.9/64"	20 1280N 038	% 38	1.1/2"			

Kleinere Ø ab 14 mm siehe Art. 20 1660N Seite 460 · **Achtung:** Die Zollabmessungen entsprechen nicht exakt den mm Durchmessern.
Smaller Ø from 14 mm see Art. 20 1660N page 460 · **Attention:** The inch sizes do not correspond exactly to the mm diameters.

20 1280N

GOLD-DRILL LINE 110

ZUBEHÖR • ACCESSORIES



AUSWERFERSTIFTE 1-TEILIG • EJECTOR PINS 1-PIECE

• 20 1399



1-teilig / 1 piece

Packnorm 2 Stk. · Packaging unit 2 pcs.

Zusammen mit Aufnahmehalter 20 1842, 20 1291, 20 1843, 20 1845, 20 1846 (siehe Seite 542–543) kann dieser einteilige Auswerferstift verwendet werden. Es kann ohne Umstecken bis 110 mm Schnitttiefe in einem Arbeitsgang gebohrt werden. Robust und einfach.

It is possible to use this one-piece ejector pin in combination with tool holder article 20 1842, 20 1291, 20 1843, 20 1845, 20 1846 (see page 542–543). You can drill as deep as 110 mm in one working process without changing. Robust and easy.

AUSWERFERSTIFTE 2-TEILIG • EJECTOR PINS 2-PIECE

• 20 1428

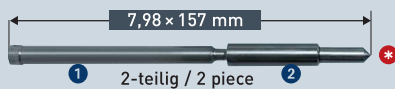

2-teilig / 2 piece

Packnorm 2 Stk. · Packaging unit 2 pcs.

ANWENDUNG AUSWERFERSTIFTE 2-TEILIG • APPLICATION EJECTOR PINS 2-PIECE



Anwendung:

Teil 1 in den Schaft des Kernbohrers einführen. Teil 2 auf Teil 1 schieben. Bohren Sie bis ca. 50 mm Schnitttiefe. Danach Teil 2 entfernen und weiter bohren.

Application:

Insert piece 1 into the annular cutter shank. Push piece 2 onto part 1. Drill as deep as 50 mm cutting depth. Then remove piece 2 and continue drilling.

* **Warum 2-teilige Auswerferstifte?** In der Regel haben Standard Morsekonus-Aufnahmehalter eine Schnitttiefenkapazität von 50 mm. Wenn **keine extra langen** Aufnahmehalter verwendet werden (wie auf Seite 542–543 Art. 20 1842, 20 1291, 20 1843, 20 1845, 20 1846), müssen bei Schnitttiefen über 50 mm 2-teilige Auswerferstifte verwendet werden.

* **Why use 2-part ejector pins?** Usually, standard morse taper holders have a cutting depth capacity of 50 mm. If **no extra-long** holders are used (e.g. as on page 542–543 Art. 20 1842, 20 1291, 20 1843, 20 1845, 20 1846), you need for drill depths above 50 mm 2-part ejector pins.

Schnittdaten
Cutting data

Film
Movie



1488





Zubehör für HSS-XE Kernbohrer, Nitto/Universalschaft, Nutzlänge 110 mm
 Accessories for HSS-XE annular cutter, Nitto/Universal shank, drill depth 110 mm | 4"

GOLD-DRILL LINE 110

20 1280N

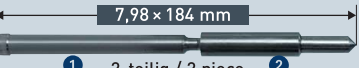

ADAPTER + PASSENDE AUSWERFERSTIFTE
ADAPTER + SUITABLE EJECTOR PINS

FEIN Quick-In 18 mm  **Weldon + Nitto/Universal 19 mm 3/4"**  **20 1161**

7,98 x 184 mm  **20 1438**

1 2-teilig / 2 piece 2

Packnorm 2 Stk. · Packaging unit 2 pcs.

Weldon 32 mm 1.1/4"  **Weldon + Nitto/Universal 19 mm 3/4"**  **21 0048**

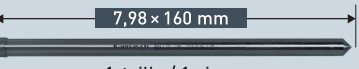
7,98 x 160 mm  **20 1399**

1-teilig / 1 piece

Packnorm 2 Stk. · Packaging unit 2 pcs.

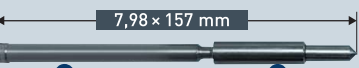
7,98 x 157 mm  **20 1428**

1 2-teilig / 2 piece 2

Packnorm 2 Stk. · Packaging unit 2 pcs.

Ersatz-Innensechskantschrauben für alle Adapter siehe Seite 550
 Spare allen screws for all adapters see page 550

ZUBEHÖR · SETS · DISPLAYS · ERSATZTEILE / ACCESSORIES · SETS · DISPLAYS · SPARE PARTS

Aufnahmehalter mit Morsekonus 2 / 3 / 4 / 5 und Reduzierhülsen  **541-543**
 Tool holders with morse taper 2 / 3 / 4 / 5 and reduction sleeves

Kühlmittel-Druckflaschen  **548**
 Coolant pressure bottles

Kegelsenker mit Weldonchaft  **544/545**
 Countersinks with Weldon shank

Magnetstab zur Entfernung der Bohrspäne  **549**
 Magnetic stick for chip removal

Spiralbohradapter Weldon + Spiralbohrer Ø 2,5-12 mm  **648**
 Twist drill adaptors Weldon + twist drills Ø 2,5-12 mm

Sets · Displays  **553-582**
 Sets · Displays

Gewindeadapter Weldon + Gewindebohrer M 3 - M 30  **649-650**
 Tapping adapter Weldon + taps M 3 - M 30

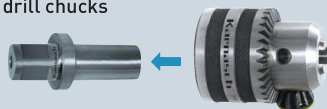
Adapter + passende Bohrfutter  **548**
 Adapters + suitable drill chucks

Ersatzteile  **550-552**
 Spare parts



20 1610

GOLD-DRILL LINE 30
ZOLL / INCH

HSS-XE Kernbohrer, Nitto/Universalschaft, Nutzlänge 30 mm
HSS-XE annular cutter, Nitto/Universal shank, drill depth 30 mm | 1"



ANWENDUNG • APPLICATION

Stahl	Edelstahl	Grauguss	Alu	Kupfer, Messing, Zinn	Kunststoffe GFK/CFK	Hardox 400, 450
Steel	Stainless	Grey cast iron	Alu	Copper, brass, tin	Plastics GRP/CRP	Hardox 400, 450
< 900 N	< 900 N		< 10% Si			

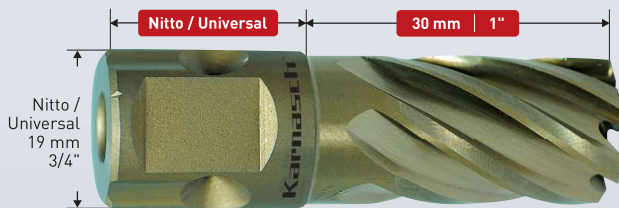

Zoll/Inch	Ø mm	Art.	Zoll/Inch	Ø mm	Art.	Zoll/Inch	Ø mm	Art.	Zoll/Inch	Ø mm	Art.
• 7/16"	11,10	20 1610 005	• 15/16"	23,81	20 1610 045	• 1.7/16"	36,51	20 1610 085	• 1.15/16"	49,21	20 1610 125
• 1/2"	12,70	20 1610 010	• 1"	25,40	20 1610 050	• 1.1/2"	38,10	20 1610 090	• 2"	50,80	20 1610 130
• 9/16"	14,28	20 1610 015	• 1.1/16"	26,98	20 1610 055	• 1.9/16"	39,68	20 1610 095	• 2.1/16"	52,38	20 1610 135
• 5/8"	15,87	20 1610 020	• 1.1/8"	28,57	20 1610 060	• 1.5/8"	41,27	20 1610 100			
• 11/16"	17,46	20 1610 025	• 1.3/16"	30,13	20 1610 065	• 1.11/16"	42,86	20 1610 105			
• 3/4"	19,04	20 1610 030	• 1.1/4"	31,75	20 1610 070	• 1.3/4"	44,45	20 1610 110			
• 13/16"	20,63	20 1610 035	• 1.5/16"	33,33	20 1610 075	• 1.13/16"	46,03	20 1610 115			
• 7/8"	22,22	20 1610 040	• 1.3/8"	34,92	20 1610 080	• 1.7/8"	47,62	20 1610 120			

Achtung: Die Zollabmessungen entsprechen nicht exakt den mm Durchmessern.
Attention: The inch sizes do not correspond exactly to the mm diameters.

20 1610

GOLD-DRILL LINE 30
ZOLL / INCH

ZUBEHÖR • ACCESSORIES



AUSWERFERSTIFTE • EJECTOR PINS



Packnorm 2 Stk. · Packaging unit 2 pcs.

Ø 7/16" • 20 1482



Packnorm 2 Stk. · Packaging unit 2 pcs.

Ø 1/2" - 2.1/16" • 20 1261

20 1610

GOLD-DRILL LINE 30
ZOLL / INCH

SETS / DISPLAYS Seite / Page 577

Wir bieten eine große Auswahl an Sets / Displays – Inhaltsvorschläge 20 1610 GOLD-DRILL LINE30 – siehe Seite 577. Anderer Inhalt auf Wunsch möglich, durch individuell bestückbare Sets / Displays.
We offer a large selection of sets / displays – recommended content 20 1610 GOLD-DRILL LINE30 – see page 577. Other content possible by individually equipped sets / displays.



Schnittdaten
Cutting data

Film
Movie



1488

- 1
- 2
- 3
- 4
- 5
- 6
- 7
- 8
- 9
- 10

Zubehör für HSS-XE Kernbohrer, Nitto/Universalschaft, Nutzlänge 30 mm
 Accessories for HSS-XE annular cutter, Nitto/Universal shank, drill depth 30 mm | 1"

GOLD-DRILL LINE 30 ZOLL / INCH **20 1610**

ADAPTER + PASSENDE AUSWERFERSTIFTE
ADAPTER + SUITABLE EJECTOR PINS

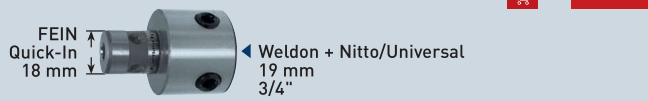

• 20 1263



• 20 1271

Packnorm 2 Stk. · Packaging unit 2 pcs.

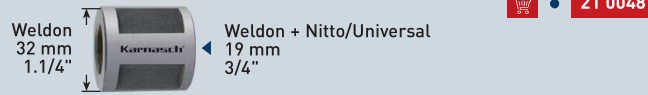

• 21 0048



• 20 1482

Packnorm 2 Stk. · Packaging unit 2 pcs.



• 20 1261

Packnorm 2 Stk. · Packaging unit 2 pcs.

Ersatz-Innensechskantschrauben für alle Adapter siehe Seite 550
 Spare allen screws for all adapters see page 550

VERLÄNGERUNGEN + PASSENDE AUSWERFERSTIFTE
EXTENSIONS + SUITABLE EJECTOR PINS



• 20 1406



• 20 1433

Packnorm 2 Stk. · Packaging unit 2 pcs.



• 20 1407



• 20 1396

Packnorm 2 Stk. · Packaging unit 2 pcs.



• 20 1409



• 20 1411

Packnorm 2 Stk. · Packaging unit 2 pcs.

Ersatz-Innensechskantschrauben für alle Verlängerungen siehe Seite 550
 Spare allen screws for all extensions see page 550

ZUBEHÖR • SETS • DISPLAYS • ERSATZTEILE / ACCESSORIES • SETS • DISPLAYS • SPARE PARTS

Aufnahmelhalter mit Morsekonus 2 / 3 / 4 / 5 und Reduzierhülsen 541-543
 Tool holders with morse taper 2 / 3 / 4 / 5 and reduction sleeves



Kegelsenker mit Weldonschaft 544/545
 Countersinks with Weldon shank

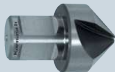

Spiralbohradapter Weldon + Spiralbohrer Ø 4-12 mm 648
 Twist drill adaptors Weldon + twist drills Ø 4-12 mm



Gewindeadapter Weldon + Gewindebohrer M 6 - M 30 649-650
 Tapping adapter Weldon + taps M 6 - M 30



Adapter + passende Bohrfutter 548
 Adapters + suitable drill chucks

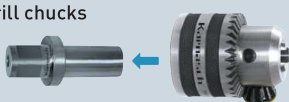

Kühlmittel-Druckflaschen 548
 Coolant pressure bottles



Magnetstab zur Entfernung der Bohrspäne 549
 Magnetic stick for chip removal



Sets · Displays 553-582
 Sets · Displays



Ersatzteile 550-552
 Spare parts



- 1
- 2
- 3
- 4
- 5
- 6
- 7
- 8
- 9
- 10 **Index**

20 1620

GOLD-DRILL LINE 55
ZOLL / INCH

HSS-XE Kernbohrer, Nitto/Universalschaft, Nutzlänge 55 mm
HSS-XE annular cutter, Nitto/Universal shank, drill depth 55 mm | 2"



ANWENDUNG • APPLICATION

Stahl	Edelstahl	Grauguss	Alu	Kupfer, Messing, Zinn	Kunststoffe GFK/CFK	Hardox 400, 450
Steel	Stainless	Grey cast iron	Alu	Copper, brass, tin	Plastics GRP/CRP	Hardox 400, 450
< 900 N	< 900 N		< 10% Si			

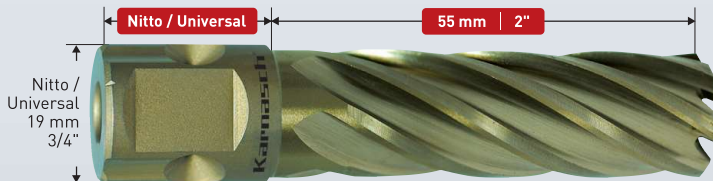

Zoll/Inch	Ø mm	Art.	Zoll/Inch	Ø mm	Art.	Zoll/Inch	Ø mm	Art.	Zoll/Inch	Ø mm	Art.
• 7/16"	11,10	20 1620 005	• 15/16"	23,81	20 1620 045	• 1.7/16"	36,51	20 1620 085	• 1.15/16"	49,21	20 1620 125
• 1/2"	12,70	20 1620 010	• 1"	25,40	20 1620 050	• 1.1/2"	38,10	20 1620 090	• 2"	50,80	20 1620 130
• 9/16"	14,28	20 1620 015	• 1.1/16"	26,98	20 1620 055	• 1.9/16"	39,68	20 1620 095	• 2.1/16"	52,38	20 1620 135
• 5/8"	15,87	20 1620 020	• 1.1/8"	28,57	20 1620 060	• 1.5/8"	41,27	20 1620 100			
• 11/16"	17,46	20 1620 025	• 1.3/16"	30,13	20 1620 065	• 1.11/16"	42,86	20 1620 105			
• 3/4"	19,04	20 1620 030	• 1.1/4"	31,75	20 1620 070	• 1.3/4"	44,45	20 1620 110			
• 13/16"	20,63	20 1620 035	• 1.5/16"	33,33	20 1620 075	• 1.13/16"	46,03	20 1620 115			
• 7/8"	22,22	20 1620 040	• 1.3/8"	34,92	20 1620 080	• 1.7/8"	47,62	20 1620 120			

Achtung: Die Zollabmessungen entsprechen nicht exakt den mm Durchmessern.
Attention: The inch sizes do not correspond exactly to the mm diameters.

20 1620

GOLD-DRILL LINE 55
ZOLL / INCH

ZUBEHÖR • ACCESSORIES



AUSWERFERSTIFTE • EJECTOR PINS



Ø 7/16" • 20 1485

Packnorm 2 Stk. · Packaging unit 2 pcs.



Ø 1/2" - 2.1/16" • 20 1271

Packnorm 2 Stk. · Packaging unit 2 pcs.

20 1620

GOLD-DRILL LINE 55
ZOLL / INCH

SETS / DISPLAYS Seite / Page 578



Wir bieten eine große Auswahl an Sets / Displays – Inhaltsvorschläge 20 1620 GOLD-DRILL LINE55 – siehe Seite 578. Anderer Inhalt auf Wunsch möglich, durch individuell bestückbare Sets / Displays.
We offer a large selection of sets / displays – recommended content 20 1620 GOLD-DRILL LINE55 – see page 578. Other content possible by individually equipped sets / displays.



Schnittdaten
Cutting data

Film
Movie



1488

- 1
- 2
- 3
- 4
- 5
- 6
- 7
- 8
- 9
- 10

Zubehör für HSS-XE Kernbohrer, Nitto/Universalschaft, Nutzlänge 55 mm
 Accessories for HSS-XE annular cutter, Nitto/Universal shank, drill depth 55 mm | 2"

GOLD-DRILL LINE 55 **20 1620**
ZOLL / INCH

ADAPTER + PASSENDE AUSWERFERSTIFTE
ADAPTER + SUITABLE EJECTOR PINS

 FEIN Quick-In 18 mm
 Weldon + Nitto/Universal 19 mm 3/4"
 • **20 1263**

 **6,34 × 130 mm**
 • **20 1160**

Packnorm 2 Stk. · Packaging unit 2 pcs.

 Weldon 32 mm 1.1/4"
 Weldon + Nitto/Universal 19 mm 3/4"
 • **21 0048**

 **4,74 × 102 mm** **Ø 7/16"** • **20 1485**

Packnorm 2 Stk. · Packaging unit 2 pcs.

 **6,34 × 102 mm** **Ø 1/2" - 2.1/16"** • **20 1271**

Packnorm 2 Stk. · Packaging unit 2 pcs.

Ersatz-Innensechskantschrauben für alle Adapter siehe Seite 550
 Spare allen screws for all adapters see page 550

VERLÄNGERUNGEN + PASSENDE AUSWERFERSTIFTE
EXTENSIONS + SUITABLE EJECTOR PINS

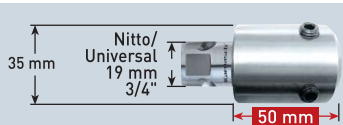
 Nitto/Universal 19 mm 3/4"
 Weldon + Nitto/Universal 19 mm 3/4"
 35 mm
 50 mm
 • **20 1406**

 **7,98 × 6,34 × 5,30 × 153 mm**
 • **20 1396**

Packnorm 2 Stk. · Packaging unit 2 pcs.

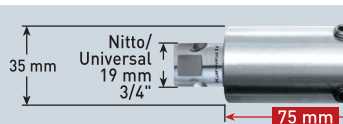
 Nitto/Universal 19 mm 3/4"
 Weldon + Nitto/Universal 19 mm 3/4"
 35 mm
 75 mm
 • **20 1407**

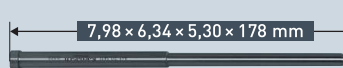
 **7,98 × 6,34 × 5,30 × 178 mm** • **20 1411**

Packnorm 2 Stk. · Packaging unit 2 pcs.

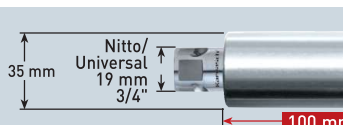
 Nitto/Universal 19 mm 3/4"
 Weldon + Nitto/Universal 19 mm 3/4"
 35 mm
 100 mm
 • **20 1409**

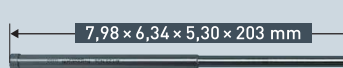
 **7,98 × 6,34 × 5,30 × 203 mm** • **20 1426**

Packnorm 2 Stk. · Packaging unit 2 pcs.

Ersatz-Innensechskantschrauben für alle Verlängerungen siehe Seite 550
 Spare allen screws for all extensions see page 550

ZUBEHÖR • SETS • DISPLAYS • ERSATZTEILE / ACCESSORIES • SETS • DISPLAYS • SPARE PARTS

Aufnahmehalter mit Morsekonus 2 / 3 / 4 / 5 und Reduzierhülsen **541-543**
 Tool holders with morse taper 2 / 3 / 4 / 5 and reduction sleeves



Kühlmittel-Druckflaschen **548**
 Coolant pressure bottles



Kegelsenker mit Weldonschaft **544/545**
 Countersinks with Weldon shank



Magnetstab zur Entfernung der Bohrspäne **549**
 Magnetic stick for chip removal



Spiralbohradapter Weldon + Spiralbohrer Ø 4-12 mm **648**
 Twist drill adaptors Weldon + twist drills Ø 4-12 mm

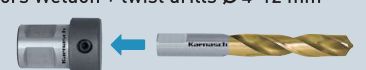

Sets · Displays **553-582**
 Sets · Displays



Gewindeadapter Weldon + Gewindebohrer M 6 - M 30 **649-650**
 Tapping adapter Weldon + taps M 6 - M 30

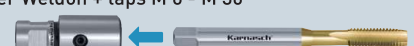

Adapter + passende Bohrfutter **548**
 Adapters + suitable drill chucks

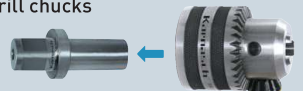

Ersatzteile **550-552**
 Spare parts



20 1625

GOLD-DRILL LINE
ZOLL / INCH 80

HSS-XE Kernbohrer, Nitto/Universalschaft, Nutzlänge 80 mm

HSS-XE annular cutter, Nitto/Universal shank, drill depth 80 mm | 3"



ANWENDUNG • APPLICATION

Stahl	Edelstahl	Grauguss	Alu	Kupfer, Messing, Zinn	Kunststoffe GFK/CFK	Hardox 400, 450
Steel	Stainless	Grey cast iron	Alu	Copper, brass, tin	Plastics GRP/CRP	Hardox 400, 450
< 900 N	< 900 N		< 10% Si			

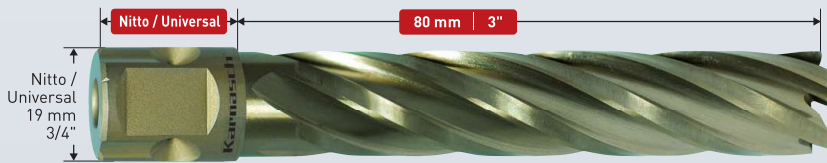

Zoll/Inch	Ø mm	Art.	Zoll/Inch	Ø mm	Art.	Zoll/Inch	Ø mm	Art.	Zoll/Inch	Ø mm	Art.
• 11/16"	17,46	20 1625 025	• 1.1/16"	26,98	20 1625 055	• 1.7/16"	36,51	20 1625 085	• 1.13/16"	46,03	20 1625 115
• 3/4"	19,04	20 1625 030	• 1.1/8"	28,57	20 1625 060	• 1.1/2"	38,10	20 1625 090	• 1.7/8"	47,62	20 1625 120
• 13/16"	20,63	20 1625 035	• 1.3/16"	30,13	20 1625 065	• 1.9/16"	39,68	20 1625 095	• 1.15/16"	49,21	20 1625 125
• 7/8"	22,22	20 1625 040	• 1.1/4"	31,75	20 1625 070	• 1.5/8"	41,27	20 1625 100	• 2"	50,80	20 1625 130
• 15/16"	23,81	20 1625 045	• 1.5/16"	33,33	20 1625 075	• 1.11/16"	42,86	20 1625 105	• 2.1/16"	52,38	20 1625 135
• 1"	25,40	20 1625 050	• 1.3/8"	34,92	20 1625 080	• 1.3/4"	44,45	20 1625 110			

Ersatzartikel siehe Art. 20 1925 Seite 434 mit passendem Adapter Art. 20 1314 + Auswerferstift Art. 20 1436, Seite 435 • **Achtung:** Die Zollabmessungen entsprechen nicht exakt den mm Durchmessern.

Replacement article Art. 20 1925 page 434 with suitable adapter Art. 20 1314 + ejector pin Art. 20 1436, page 435 • **Attention:** The inch sizes do not correspond exactly to the mm diameters.

20 1625

GOLD-DRILL LINE
ZOLL / INCH 80

ZUBEHÖR • ACCESSORIES



AUSWERFERSTIFTE 1-TEILIG • EJECTOR PINS 1-PIECE

• 20 1439



1-teilig / 1 piece

Packnorm 2 Stk. • Packaging unit 2 pcs.

Zusammen mit Aufnahmehalter 20 1842, 20 1291, 20 1843, 20 1845, 20 1846 (siehe Seite 542–543) kann dieser einteilige Auswerferstift verwendet werden. Es kann ohne Umstecken bis 110 mm Schnitttiefe in einem Arbeitsgang gebohrt werden. Robust und einfach.

It is possible to use this one-piece ejector pin in combination with tool holder article 20 1842, 20 1291, 20 1843, 20 1845, 20 1846 (see page 542–543). You can drill as deep as 110 mm in one working process without changing. Robust and easy.

AUSWERFERSTIFTE 2-TEILIG EJECTOR PINS 2-PIECE

• 20 1427



2-teilig / 2 piece

Packnorm 2 Stk. • Packaging unit 2 pcs.

ANWENDUNG AUSWERFERSTIFTE 2-TEILIG APPLICATION EJECTOR PINS 2-PIECE



Anwendung:

Teil 1 in den Schaft des Kernbohrers einführen. Teil 2 auf Teil 1 schieben. Bohren Sie bis ca. 50 mm Schnitttiefe. Danach Teil 2 entfernen und weiter bohren.

Application:

Insert piece 1 into the annular cutter shank. Push piece 2 onto part 1. Drill as deep as 50 mm cutting depth. Then remove piece 2 and continue drilling.

• **Warum 2-teilige Auswerferstifte?** In der Regel haben Standard Morsekonus-Aufnahmehalter eine Schnitttiefenkapazität von 50 mm. Wenn **keine extra langen** Aufnahmehalter verwendet werden (wie auf Seite 542–543 Art. 20 1842, 20 1291, 20 1843, 20 1845, 20 1846), müssen bei Schnitttiefen über 50 mm 2-teilige Auswerferstifte verwendet werden.

• **Why use 2-part ejector pins?** Usually, standard morse taper holders have a cutting depth capacity of 50 mm. If **no extra-long** holders are used (e.g. as on page 542–543 Art. 20 1842, 20 1291, 20 1843, 20 1845, 20 1846), you need for drill depths above 50 mm 2-part ejector pins.

Schnittdaten
Cutting data

Film
Movie



1488



Zubehör für HSS-XE Kernbohrer, Nitto/Universalschaft, Nutzlänge 80 mm
 Accessories for HSS-XE annular cutter, Nitto/Universal shank, drill depth 80 mm | 3"

GOLD-DRILL LINE 80
ZOLL / INCH

20 1625

ADAPTER + PASSENDE AUSWERFERSTIFTE
ADAPTER + SUITABLE EJECTOR PINS



• **20 1161**



• **20 1436**

Packnorm 2 Stk. · Packaging unit 2 pcs.



• **21 0048**



• **20 1439**

Packnorm 2 Stk. · Packaging unit 2 pcs.

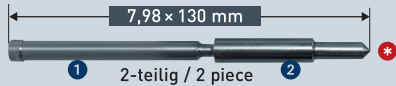

• **20 1427**

Packnorm 2 Stk. · Packaging unit 2 pcs.

Ersatz-Innensechskantschrauben für alle Adapter siehe Seite 550
 Spare allen screws for all adapters see page 550

ZUBEHÖR · SETS · DISPLAYS · ERSATZTEILE / ACCESSORIES · SETS · DISPLAYS · SPARE PARTS

Aufnahmehalter mit Morsekonus 2 / 3 / 4 / 5 und Reduzierhülsen  541-543
 Tool holders with morse taper 2 / 3 / 4 / 5 and reduction sleeves



Kühlmittel-Druckflaschen  548
 Coolant pressure bottles



Kegelsenker mit Weldonchaft  544/545
 Countersinks with Weldon shank

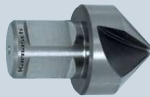

Magnetstab zur Entfernung der Bohrspäne  549
 Magnetic stick for chip removal



Spiralbohradapter Weldon + Spiralbohrer Ø 2,5-12 mm  648
 Twist drill adaptors Weldon + twist drills Ø 2,5-12 mm



Sets · Displays  553-582
 Sets · Displays



Gewindeadapter Weldon + Gewindebohrer M 3 - M 30  649-650
 Tapping adapter Weldon + taps M 3 - M 30



Adapter + passende Bohrfutter  548
 Adapters + suitable drill chucks

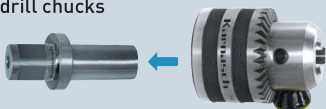

Ersatzteile  550-552
 Spare parts

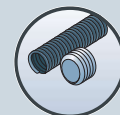

20 1635

GOLD-DRILL LINE
ZOLL / INCH 110

HSS-XE Kernbohrer, Nitto/Universalschaft, Nutzlänge 110 mm
HSS-XE annular cutter, Nitto/Universal shank, drill depth 110 mm | 4"



ANWENDUNG • APPLICATION

Stahl	Edelstahl	Grauguss	Alu	Kupfer, Messing, Zinn	Kunststoffe GFK/CFK	Hardox 400, 450
Steel	Stainless	Grey cast iron	Alu	Copper, brass, tin	Plastics GRP/CRP	Hardox 400, 450
< 900 N	< 900 N		< 10% Si			



Zoll/Inch	Ø mm	Art.	Zoll/Inch	Ø mm	Art.	Zoll/Inch	Ø mm	Art.	Zoll/Inch	Ø mm	Art.
• 11/16"	17,46	20 1635 025	• 1.1/16"	26,98	20 1635 055	• 1.7/16"	36,51	20 1635 085	• 1.13/16"	46,03	20 1635 115
• 3/4"	19,04	20 1635 030	• 1.1/8"	28,57	20 1635 060	• 1.1/2"	38,10	20 1635 090	• 1.7/8"	47,62	20 1635 120
• 13/16"	20,63	20 1635 035	• 1.3/16"	30,13	20 1635 065	• 1.9/16"	39,68	20 1635 095	• 1.15/16"	49,21	20 1635 125
• 7/8"	22,22	20 1635 040	• 1.1/4"	31,75	20 1635 070	• 1.5/8"	41,27	20 1635 100	• 2"	50,80	20 1635 130
• 15/16"	23,81	20 1635 045	• 1.5/16"	33,33	20 1635 075	• 1.11/16"	42,86	20 1635 105	• 2.1/16"	52,38	20 1635 135
• 1"	25,40	20 1635 050	• 1.3/8"	34,92	20 1635 080	• 1.3/4"	44,45	20 1635 110			

Achtung: Die Zollabmessungen entsprechen nicht exakt den mm Durchmesser.
Attention: The inch sizes do not correspond exactly to the mm diameters.

20 1635

GOLD-DRILL LINE
ZOLL / INCH 110

ZUBEHÖR • ACCESSORIES



AUSWERFERSTIFTE 1-TEILIG • EJECTOR PINS 1-PIECE

• 20 1399



1-teilig / 1 piece

Packnorm 2 Stk. · Packaging unit 2 pcs.

Zusammen mit Aufnahmehalter 20 1842, 20 1291, 20 1843, 20 1845, 20 1846 (siehe Seite 542–543) kann dieser einteilige Auswerferstift verwendet werden. Es kann ohne Umstecken bis 110 mm Schnitttiefe in einem Arbeitsgang gebohrt werden. Robust und einfach.

It is possible to use this one-piece ejector pin in combination with tool holder article 20 1842, 20 1291, 20 1843, 20 1845, 20 1846 (see page 542–543). You can drill as deep as 110 mm in one working process without changing. Robust and easy.

AUSWERFERSTIFTE 2-TEILIG EJECTOR PINS 2-PIECE

• 20 1428

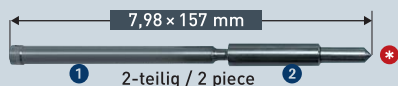

2-teilig / 2 piece

Packnorm 2 Stk. · Packaging unit 2 pcs.

ANWENDUNG AUSWERFERSTIFTE 2-TEILIG APPLICATION EJECTOR PINS 2-PIECE



Anwendung:

Teil 1 in den Schaft des Kernbohrers einführen. Teil 2 auf Teil 1 schieben. Bohren Sie bis ca. 50 mm Schnitttiefe. Danach Teil 2 entfernen und weiter bohren.

Application:

Insert piece 1 into the annular cutter shank. Push piece 2 onto part 1. Drill as deep as 50 mm cutting depth. Then remove piece 2 and continue drilling.

• **Warum 2-teilige Auswerferstifte?** In der Regel haben Standard Morsekonus-Aufnahmehalter eine Schnitttiefenkapazität von 50 mm. Wenn **keine extra langen** Aufnahmehalter verwendet werden (wie auf Seite 542–543 Art. 20 1842, 20 1291, 20 1843, 20 1845, 20 1846), müssen bei Schnitttiefen über 50 mm 2-teilige Auswerferstifte verwendet werden.

• **Why use 2-part ejector pins?** Usually, standard morse taper holders have a cutting depth capacity of 50 mm. If **no extra-long** holders are used (e.g. as on page 542–543 Art. 20 1842, 20 1291, 20 1843, 20 1845, 20 1846), you need for drill depths above 50 mm 2-part ejector pins.

Schnittdaten
Cutting data

Film
Movie



1488





Zubehör für HSS-XE Kernbohrer, Nitto/Universalschaft, Nutzlänge 110 mm
 Accessories for HSS-XE annular cutter, Nitto/Universal shank, drill depth 110 mm | 4"

GOLD-DRILL LINE 110
 ZOLL / INCH

20 1635

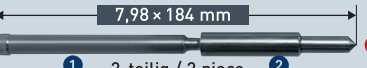

ADAPTER + PASSENDE AUSWERFERSTIFTE
ADAPTER + SUITABLE EJECTOR PINS

FEIN Quick-In 18 mm  **Weldon + Nitto/Universal 19 mm 3/4"**  **20 1161**

7,98 x 184 mm  **20 1438**

1 2-teilig / 2 piece 2

Packnorm 2 Stk. · Packaging unit 2 pcs.

Weldon 32 mm 1.1/4"  **Weldon + Nitto/Universal 19 mm 3/4"**  **21 0048**

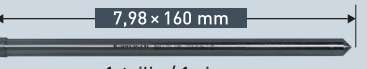
7,98 x 160 mm  **20 1399**

1-teilig / 1 piece

Packnorm 2 Stk. · Packaging unit 2 pcs.

7,98 x 157 mm  **20 1428**

1 2-teilig / 2 piece 2

Packnorm 2 Stk. · Packaging unit 2 pcs.

Ersatz-Innensechskantschrauben für alle Adapter siehe Seite 550
 Spare allen screws for all adapters see page 550

ZUBEHÖR · SETS · DISPLAYS · ERSATZTEILE / ACCESSORIES · SETS · DISPLAYS · SPARE PARTS

Aufnahmehalter mit Morsekonus 2 / 3 / 4 / 5 und Reduzierhülsen  541-543
 Tool holders with morse taper 2 / 3 / 4 / 5 and reduction sleeves

Kühlmittel-Druckflaschen  548
 Coolant pressure bottles

Kegelsenker mit Weldonchaft  544/545
 Countersinks with Weldon shank

Magnetstab zur Entfernung der Bohrspäne  549
 Magnetic stick for chip removal

Spiralbohradapter Weldon + Spiralbohrer Ø 2,5-12 mm  648
 Twist drill adaptors Weldon + twist drills Ø 2,5-12 mm

Sets · Displays  553-582
 Sets · Displays

Gewindeadapter Weldon + Gewindebohrer M 3 - M 30  649-650
 Tapping adapter Weldon + taps M 3 - M 30

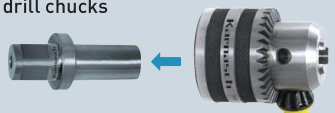
Adapter + passende Bohrfutter  548
 Adapters + suitable drill chucks

Ersatzteile  550-552
 Spare parts

- 1 
- 2 
- 3 
- 4 
- 5 
- 6 
- 7 
- 8 
- 9 
- 10 **Index**

20 1240

GOLD-DRILL LINE SANDWICH 30

HSS-XE Kernbohrer, Nitto/Universalschaft, Nutzlänge 30 mm
HSS-XE annular cutter, Nitto/Universal shank, drill depth 30 mm | 1"

20 1241

GOLD-DRILL LINE SANDWICH ZOLL / INCH 30

ANWENDUNG • APPLICATION

Stahl	Edelstahl	Grauguss	Alu	Kupfer, Messing, Zinn	Kunststoffe GFK/CFK	Hardox 400, 450
Steel	Stainless	Grey cast iron	Alu	Copper, brass, tin	Plastics GRP/CRP	Hardox 400, 450
< 900 N	< 900 N		< 10% Si			

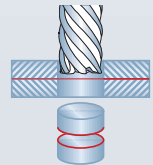
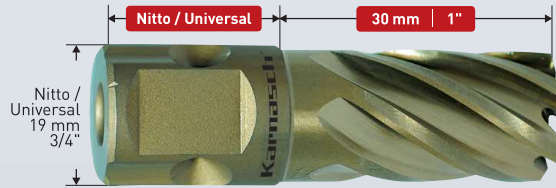

Mehrschichtenbohrer. Spezialgeometrie zum Bohren übereinanderliegender Metallplatten bis 1100 N (Sandwich)
Multi layer drill. For stack drilling (sandwich) in steel up to 1100 N

Art.	Ø mm	Ø Zoll Inch	Art.	Ø mm	Ø Zoll Inch
20 1240 019	19	3/4"	20 1240 032	32	1.17/64"
20 1240 020	20	25/32"			
20 1240 024	24	15/16"			
20 1240 030	30	1.3/16"			

Zoll/Inch	Ø mm	Art.	Zoll/Inch	Ø mm	Art.
5/8"	15,87	20 1241 010	15/16"	23,81	20 1241 035
3/4"	19,04	20 1241 020	1.1/16"	26,98	20 1241 045
13/16"	20,63	20 1241 025			
7/8"	22,22	20 1241 030			

Achtung: Die Zollabmessungen entsprechen nicht exakt den mm Durchmesser.
Attention: The inch sizes do not correspond exactly to the mm diameters.

% Sonderpreis / Sale Artikel. Lieferbar solange Vorrat.
Special price / sale article. While stocks last.

20 1240

GOLD-DRILL LINE SANDWICH 30

20 1241

GOLD-DRILL LINE SANDWICH ZOLL / INCH 30

ZUBEHÖR • ACCESSORIES



AUSWERFERSTIFTE • EJECTOR PINS

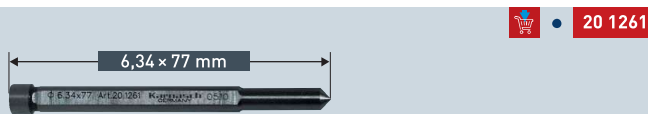

Packnorm 2 Stk. · Packaging unit 2 pcs.

Schnittdaten
Cutting data

Film
Movie



1488

Zubehör für HSS-XE Kernbohrer, Nitto/Universalschaft, Nutzlänge 30 mm
 Accessories for HSS-XE annular cutter, Nitto/Universal shank, drill depth 30 mm | 1"

20 1240
GOLD-DRILL LINE
 SANDWICH 30

20 1241
GOLD-DRILL LINE
 SANDWICH ZOLL / INCH 30

ADAPTER + PASSENDE AUSWERFERSTIFTE
ADAPTER + SUITABLE EJECTOR PINS



• 20 1263



• 20 1271

Packnorm 2 Stk. · Packaging unit 2 pcs.



• 21 0048



• 20 1261

Packnorm 2 Stk. · Packaging unit 2 pcs.

Ersatz-Innensechskantschrauben für alle Adapter siehe Seite 550
 Spare allen screws for all adapters see page 550

VERLÄNGERUNGEN + PASSENDE AUSWERFERSTIFTE
EXTENSIONS + SUITABLE EJECTOR PINS



• 20 1406

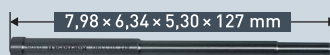

• 20 1433

Packnorm 2 Stk. · Packaging unit 2 pcs.



• 20 1407

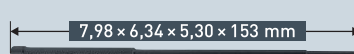

• 20 1396

Packnorm 2 Stk. · Packaging unit 2 pcs.



• 20 1409

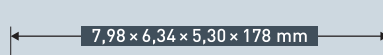

• 20 1411

Packnorm 2 Stk. · Packaging unit 2 pcs.

Ersatz-Innensechskantschrauben für alle Verlängerungen siehe Seite 550
 Spare allen screws for all extensions see page 550

ZUBEHÖR • SETS • DISPLAYS • ERSATZTEILE / ACCESSORIES • SETS • DISPLAYS • SPARE PARTS

Aufnahmehalter mit Morsekonus 2 / 3 / 4 / 5 und Reduzierhülsen 541-543
 Tool holders with morse taper 2 / 3 / 4 / 5 and reduction sleeves



Kühlmittel-Druckflaschen 548
 Coolant pressure bottles



Kegelsenker mit Weldonschaft 544/545
 Countersinks with Weldon shank

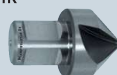

Magnetstab zur Entfernung der Bohrspäne 549
 Magnetic stick for chip removal



Spiralbohradapter Weldon + Spiralbohrer Ø 4-12 mm 648
 Twist drill adaptors Weldon + twist drills Ø 4-12 mm



Sets · Displays 553-582
 Sets · Displays



Gewindeadapter Weldon + Gewindebohrer M 6 - M 30 649-650
 Tapping adapter Weldon + taps M 6 - M 30



Adapter + passende Bohrfutter 548
 Adapters + suitable drill chucks

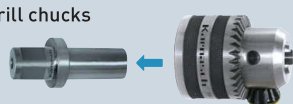

Ersatzteile 550-552
 Spare parts



- 1
- 2
- 3
- 4
- 5
- 6
- 7
- 8
- 9
- 10

20 1242

GOLD-DRILL LINE SANDWICH 55

HSS-XE Kernbohrer, Nitto/Universalschaft, Nutzlänge 55 mm
HSS-XE annular cutter, Nitto/Universal shank, drill depth 55 mm | 2"

20 1243

GOLD-DRILL LINE SANDWICH ZOLL / INCH 55



ANWENDUNG • APPLICATION

Stahl	Edelstahl	Grauguss	Alu	Kupfer, Messing, Zinn	Kunststoffe GFK/CFK	Hardox 400, 450
Steel	Stainless	Grey cast iron	Alu	Copper, brass, tin	Plastics GRP/CRP	Hardox 400, 450
< 900 N	< 900 N		< 10% Si			

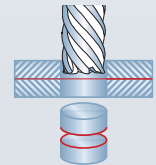
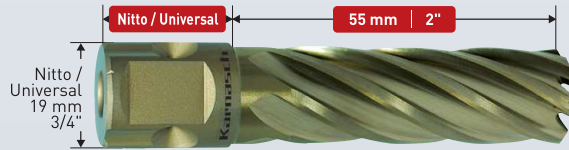

Mehrschichtenbohrer. Spezialgeometrie zum Bohren übereinanderliegender Metallplatten bis 1100 N (Sandwich)
Multi layer drill. For stack drilling (sandwich) in steel up to 1100 N

Art.	Ø mm	Ø Zoll Inch	Art.	Ø mm	Ø Zoll Inch
20 1242 016	16	5/8"	20 1242 025	25	63/64"
20 1242 019	19	3/4"	20 1242 026	26	1.1/32"
20 1242 022	22	55/64"	20 1242 030	30	1.3/16"
20 1242 024	24	15/16"	20 1242 032	32	1.17/64"

Ø Zoll Inch	Ø mm	Art.	Ø Zoll Inch	Ø mm	Art.
9/16"	14,28	20 1243 005	7/8"	22,22	20 1243 030
5/8"	15,87	20 1243 010	15/16"	23,81	20 1243 035
3/4"	19,04	20 1243 020	1"	25,40	20 1243 040
13/16"	20,63	20 1243 025	1.1/16"	26,98	20 1243 045

Achtung: Die Zollabmessungen entsprechen nicht exakt den mm Durchmessern.
Attention: The inch sizes do not correspond exactly to the mm diameters.

⚡ Sonderpreis / Sale Artikel. Lieferbar solange Vorrat.
Special price / sale article. While stocks last.

20 1242

GOLD-DRILL LINE SANDWICH 55

20 1243

GOLD-DRILL LINE SANDWICH ZOLL / INCH 55

ZUBEHÖR • ACCESSORIES



AUSWERFERSTIFTE • EJECTOR PINS

20 1271



Packnorm 2 Stk. - Packaging unit 2 pcs.

Schnittdaten
Cutting data

Film
Movie



1488



Zubehör für HSS-XE Kernbohrer, Nitto/Universalschaft, Nutzlänge 55 mm
 Accessories for HSS-XE annular cutter, Nitto/Universal shank, drill depth 55 mm | 2"

20 1242
GOLD-DRILL LINE
 SANDWICH 55

20 1243
GOLD-DRILL LINE
 SANDWICH ZOLL / INCH 55

ADAPTER + PASSENDE AUSWERFERSTIFTE
ADAPTER + SUITABLE EJECTOR PINS



• 20 1263



• 20 1160

Packnorm 2 Stk. · Packaging unit 2 pcs.



• 21 0048



• 20 1271

Packnorm 2 Stk. · Packaging unit 2 pcs.

Ersatz-Innensechskantschrauben für alle Adapter siehe Seite 550
 Spare allen screws for all adapters see page 550

VERLÄNGERUNGEN + PASSENDE AUSWERFERSTIFTE
EXTENSIONS + SUITABLE EJECTOR PINS



• 20 1406

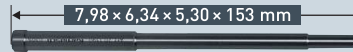

• 20 1396

Packnorm 2 Stk. · Packaging unit 2 pcs.

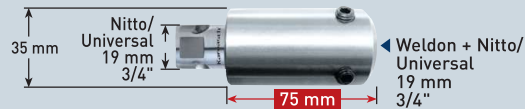

• 20 1407

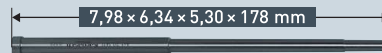

• 20 1411

Packnorm 2 Stk. · Packaging unit 2 pcs.



• 20 1409

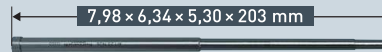

• 20 1426

Packnorm 2 Stk. · Packaging unit 2 pcs.

Ersatz-Innensechskantschrauben für alle Verlängerungen siehe Seite 550
 Spare allen screws for all extensions see page 550

ZUBEHÖR • SETS • DISPLAYS • ERSATZTEILE / ACCESSORIES • SETS • DISPLAYS • SPARE PARTS

Aufnahmelhalter mit Morsekonus 2 / 3 / 4 / 5 und Reduzierhülsen 541-543
 Tool holders with morse taper 2 / 3 / 4 / 5 and reduction sleeves



Kühlmittel-Druckflaschen 548
 Coolant pressure bottles



Kegelsenker mit Weldonschaft 544/545
 Countersinks with Weldon shank

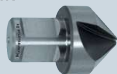

Magnetstab zur Entfernung der Bohrspäne 549
 Magnetic stick for chip removal



Spiralbohradapter Weldon + Spiralbohrer Ø 4-12 mm 648
 Twist drill adaptors Weldon + twist drills Ø 4-12 mm



Sets · Displays 553-582
 Sets · Displays



Gewindeadapter Weldon + Gewindebohrer M 6 - M 30 649-650
 Tapping adapter Weldon + taps M 6 - M 30



Adapter + passende Bohrfutter 548
 Adapters + suitable drill chucks

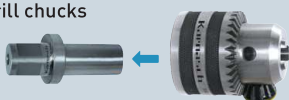

Ersatzteile 550-552
 Spare parts



- 1 
- 2 
- 3 
- 4 
- 5 
- 6 
- 7 
- 8 
- 9 
- 10 

**KERNBOHRER FEIN QUICK-IN SCHAFT 18 MM /
FEIN QUICK-IN MAX-SCHAFT 32 MM**

**ANNULAR CUTTERS FEIN QUICK-IN SHANK 18 MM /
FEIN QUICK-IN MAX-SHANK 32 MM (1.1/4")**



















































Passende Kernbohrmaschinen von Fein:
Matching machines made by Fein:

FEIN TYPE: KBM 32 Q · KBM 50 Q · KBM 50 U · KBM 50 AUTO ·
KBM 65 U · KBM 80 QUICK-IN MAX

FEIN QUICK-IN

Übersicht Kernbohrer Fein Quick-In Schaft

Overview annular cutters Fein Quick-In shank

TYPE	Ø	Beschreibung · Specification	Anwendung · Application																															
HARD-LINE	Ø 12-65 mm Ø 15/32-2.9/16"	<p>Kernbohrer Hartmetall-bestückt Die leistungsstärksten Kernbohrer in unserem Sortiment. Exzellent für alle Stähle bis 1400 N Festigkeit sowie für alle Edelstähle.</p> <p>Annular cutters carbide-tipped The most powerful annular cutters in our range. Excellent for all steels up to a strength of 1400 N and for all stainless steels.</p>	<table border="1"> <tr> <td></td> <td></td> <td></td> <td></td> <td></td> </tr> <tr> <td>Stahl</td> <td>Edelstahl</td> <td>Grauguss</td> <td>Alu</td> <td>Kupfer, Messing, Zinn</td> </tr> <tr> <td>Steel</td> <td>Stainless</td> <td>Grey cast iron</td> <td>Alu</td> <td>Copper, brass, tin</td> </tr> <tr> <td>< 1400 N ✓</td> <td>> 900 N ✓</td> <td>✓</td> <td>> 10% Si ✓</td> <td>✓</td> </tr> </table>						Stahl	Edelstahl	Grauguss	Alu	Kupfer, Messing, Zinn	Steel	Stainless	Grey cast iron	Alu	Copper, brass, tin	< 1400 N ✓	> 900 N ✓	✓	> 10% Si ✓	✓	508-511										
																																		
Stahl	Edelstahl	Grauguss	Alu	Kupfer, Messing, Zinn																														
Steel	Stainless	Grey cast iron	Alu	Copper, brass, tin																														
< 1400 N ✓	> 900 N ✓	✓	> 10% Si ✓	✓																														
BLUE-DRILL LINE	Ø 12-60 mm Ø 15/32-2.23/64"	<p>Kernbohrer aus HSS-XE Spezialstahl + DURABLU- Beschichtung. Der am meisten verwendete beschichtete Kernbohrer für alle Stähle bis 1100 N Festigkeit sowie für alle Edelstähle.</p> <p>Annular cutters made of HSS-XE special steel + DURABLU-coating. The most-often used coated annular cutter for all steels up to a strength of 1100 N and for all stainless steels.</p>	<table border="1"> <tr> <td></td> <td></td> <td></td> <td></td> <td></td> </tr> <tr> <td>Stahl</td> <td>Edelstahl</td> <td>Grauguss</td> <td>Alu</td> <td>Kupfer, Messing, Zinn</td> </tr> <tr> <td>Steel</td> <td>Stainless</td> <td>Grey cast iron</td> <td>Alu</td> <td>Copper, brass, tin</td> </tr> <tr> <td>< 1100 N ✓</td> <td>< 900 N ✓</td> <td>✓</td> <td>> 10% Si ✓</td> <td>✓</td> </tr> <tr> <td></td> <td></td> <td></td> <td></td> <td></td> </tr> <tr> <td>Hardox 400 Hardox 400 ✓</td> <td>Hardox 450 Hardox 450 ✓</td> <td></td> <td></td> <td></td> </tr> </table>						Stahl	Edelstahl	Grauguss	Alu	Kupfer, Messing, Zinn	Steel	Stainless	Grey cast iron	Alu	Copper, brass, tin	< 1100 N ✓	< 900 N ✓	✓	> 10% Si ✓	✓						Hardox 400 Hardox 400 ✓	Hardox 450 Hardox 450 ✓				514-516
																																		
Stahl	Edelstahl	Grauguss	Alu	Kupfer, Messing, Zinn																														
Steel	Stainless	Grey cast iron	Alu	Copper, brass, tin																														
< 1100 N ✓	< 900 N ✓	✓	> 10% Si ✓	✓																														
																																		
Hardox 400 Hardox 400 ✓	Hardox 450 Hardox 450 ✓																																	
GOLD-DRILL LINE	Ø 12-60 mm Ø 15/32-2.23/64"	<p>Kernbohrer aus HSS-XE Spezialstahl + GOLD-TECH-Behandlung. Der am meisten verwendete nicht beschichtete Kernbohrer für alle Stähle bis 900 N Festigkeit. Auch noch für Edelstahl geeignet.</p> <p>Annular cutters made of HSS-XE special steel + GOLD-TECH treatment. The most-often used uncoated annular cutter for all steels up to a strength of 900 N. Still suitable for stainless steels.</p>	<table border="1"> <tr> <td></td> <td></td> <td></td> <td></td> </tr> <tr> <td>Stahl</td> <td>Edelstahl</td> <td>Alu</td> <td>Kupfer, Messing, Zinn</td> </tr> <tr> <td>Steel</td> <td>Stainless</td> <td>Alu</td> <td>Copper, brass, tin</td> </tr> <tr> <td>< 900 N ✓</td> <td>< 900 N ✓</td> <td>< 10% Si ✓</td> <td>✓</td> </tr> </table>					Stahl	Edelstahl	Alu	Kupfer, Messing, Zinn	Steel	Stainless	Alu	Copper, brass, tin	< 900 N ✓	< 900 N ✓	< 10% Si ✓	✓	518-520														
																																		
Stahl	Edelstahl	Alu	Kupfer, Messing, Zinn																															
Steel	Stainless	Alu	Copper, brass, tin																															
< 900 N ✓	< 900 N ✓	< 10% Si ✓	✓																															

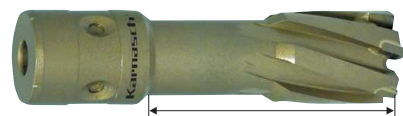

40, 55 mm
1.1/2", 2"

Schnittiefen
Drill depths



40 mm
1.1/2"

Schnittiefen
Drill depths



40 mm
1.1/2"

Schnittiefen
Drill depths

1

2

3

4

5

6

7

8

9

10

Index

HARTMETALL-BESTÜCKTE KERNBOHRER CARBIDE-TIPPED ANNULAR CUTTERS



HARD-LINE

Der beste Kernbohrer ist grundsätzlich Hartmetall-bestückt.

Nur diese Bohrer bieten das optimale Preis-Leistungs-Verhältnis für nahezu alle Materialien. Neben der höchsten Standzeit in allen Stählen bieten nur Hartmetall-bestückte Kernbohrer:

- Bohren in Stähle bis 40 Rockwell (HRC)
- Bohren in alle Edelstähle
- Bohren in schwierigste Legierungen (Hardox/Inconel/Titan)
- Bohren hervorragend auch in weiche Werkstoffe wie Alu, Kupfer, Messing u.ä.

Mit Durchmessern von 12-65 mm in Schnitttiefen von 40, 55 und 80 mm steht Ihnen weltweit das umfangreichste Lagerprogramm zur Verfügung.

The fact is: The best annular cutters are carbide tipped.

Only these drills offer the best value for money for almost all materials. Only carbide tipped annular cutters provide maximum cutting capacity in all kinds of steels:

- Drilling in hardened steel up to 40 Rockwell (HRC)
- Drilling in all sorts of stainless steel
- Drilling in most difficult alloys (Hardox/Inconel/Titan)
- Drilling also excellent in all non-ferrous metals such as alu, copper, brass

Available in diameter 12-65 mm. Available in drill depths 40 mm, 55 mm and 80 mm. Simply the world's largest stock range of carbide tipped annular cutter.

EIGENSCHAFTEN · PROPERTIES



Karnasch Hartmetall-bestückte Kernbohrer (HARD-LINE) werden mit konischer Spirale gefertigt für: Sauberen Spanfluss und höchste Zerspanleistung auch bei schwierigen Materialien.

Karnasch carbide tipped annular cutters (HARD-LINE) are made with a conical helix for: clean chip flow and highest cutting ability even with difficult materials.



Karnasch Hartmetall-bestückte Kernbohrer (HARD-LINE) werden ausschließlich mit Sandvik Hartmetallzähnen bestückt. Wir meinen: Nur das beste Hartmetall ist gut genug für Karnasch Kernbohrer.

Karnasch carbide tipped annular cutters (HARD-LINE) are exclusively equipped with Sandvik carbide teeth. Our opinion is: Only the best carbide is good enough for Karnasch annular cutters.

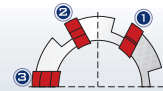

Karnasch Hartmetall-bestückte Kernbohrer (HARD-LINE) sind in einer aufwendigen Vor-Mittel-Nachsneider-Geometrie gefertigt. Dies ergibt: ratterfreies, ruhiges und leichtes Zerspanen mit höchsten Standzeiten.

Karnasch carbide tipped annular cutters (HARD-LINE) are made in an elaborate pre-/intermediate-/after-cutting geometry. This results in: clatter-free, silent and easy cutting with highest lifetimes.

ANWENDUNG · APPLICATION

Stahl	Edelstahl	Alu	Kupfer, Messing, Zinn	Kunststoffe GFK/CFK	Grauguss	Graphit	Hastelloy, Inconel, Nimonic, Exotische Materialien	Schienen
Steel	Stainless	Alu	Copper, brass, tin	Plastics GRP/CRP	Grey cast iron	Graphite	Hastelloy, Inconel, Nimonic, exotic materials	Rails
< 1400 N	> 900 N	> 10% Si						
✓	✓	✓	✓	✓	✓	✓	✓	✓

✓ OPTIMAL · OPTIMAL

✓ GUT · GOOD

✓ MÖGLICH · POSSIBLE

HARTMETALL-BESTÜCKTE KERNBOHRER CARBIDE-TIPPED ANNULAR CUTTERS

HARD-LINE

Schnitttiefe · Drill depths

	Ø mm	Ø Zoll/Inch	Art. / Type	
 <p>Fein Quick-In 40 mm 1.1/2"</p>	12-65	15/32-2.9/16"	20 1147 HARD-LINE/40	510
 <p>Fein Quick-In 55 mm 2"</p>	12-60	15/32-2.23/64"	20 1148 HARD-LINE/55	511
 <p>Fein Quick-In 80 mm 3"</p>	14-40	35/64"-1.37/64"	20 1190 HARD-LINE/80	512

neu
new

HINWEISE · NOTES

Sie benötigen größere Schnitttiefen wie z. B. 80 mm oder 110 mm?

Arbeiten Sie mit Fein Adapter + Weldon Kernbohrer.
Siehe Art. 20 1650 (Schnitttiefe 80 mm) Seite 386
Siehe Art. 20 1660 (Schnitttiefe 110 mm) Seite 388

Require larger drill depths such as 80 mm or 110 mm?

Work with adapter Fein + Weldon annular cutters.
See Art. 20 1650 (cutting depth 80 mm) page 386
See Art. 20 1660 (cutting depth 110 mm) page 388

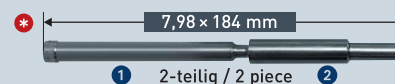

Packnorm 2 Stk.
Packaging unit 2 pcs.

Sie benötigen größere Durchmesser bis 100 mm?

Arbeiten Sie mit Fein Quick-In und Fein Quick-In Max Adaptern +
Power-Max Lochsägen siehe Seite 584

Require a larger diameter up to 100 mm?

Work with adapter Fein Quick-In or Fein Quick-In Max + our
Power-Max hole saws see page 584

Sie benötigen kleinere Durchmesser wie:

6 mm, 8 mm, 9,8 mm, 10 mm, 11 mm?
Siehe Artikel 20 1430 Seite 446

Require a smaller diameter such as:

6 mm, 8 mm, 9,8 mm, 10 mm, 11 mm?
See article 20 1430 page 446

FEIN QUICK-IN 18 mm

Passend für Maschinen ·
Suitable for machines
FEIN KBM 32 Q · KBM 50 Q · KBM
50 U · KBM 50 Auto · KBM 65 U



FEIN QUICK-IN MAX 32 mm 1.1/4"

Für Fein Maschine ·
For Fein machine
FEIN KBM 80 Quick-In Max

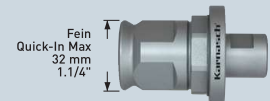

DRILL-LINE 30 PRO



- 1
- 2
- 3
- 4
- 5
- 6
- 7
- 8
- 9
- 10

Index

20 1147

HARD-LINE/40

Hartmetall-bestückter Kernbohrer, Fein Quick-In Schaft, Nutzlänge 40 mm
Carbide-tipped annular cutter, Fein Quick-In shank, drill depth 40 mm | 1.1/2"



ANWENDUNG • APPLICATION

Stahl	Edelstahl	Grauguss	Alu	Kupfer, Messing, Zinn	Kunststoffe GFK/CFK	Hastelloy, Inconel, Exotische Materialien
Steel	Stainless	Grey cast iron	Alu	Copper, brass, tin	Plastics GRP/CRP	Hastelloy, Inconel, exotic materials
< 1400 N	> 900 N		> 10% Si			

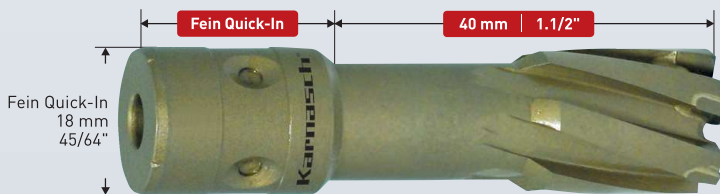

☒ Sonderpreis / Sale Artikel. Lieferbar solange Vorrat.
Special price / sale article. While stocks last.

Art.	Ø mm	Ø Zoll Inch	Art.	Ø mm	Ø Zoll Inch	Art.	Ø mm	Ø Zoll Inch	Art.	Ø mm	Ø Zoll Inch
20 1147 012	12	15/32"	20 1147 026	26	1.1/32"	20 1147 040	40	1.37/64"	20 1147 054	54	2.1/8"
20 1147 013	13	33/64"	20 1147 027	27	1.1/16"	20 1147 041	41	1.39/64"	20 1147 055	55	2.11/64"
20 1147 014	14	35/64"	20 1147 028	28	1.7/64"	20 1147 042	42	1.21/32"	20 1147 056	56	2.13/64"
20 1147 015	15	19/32"	20 1147 029	29	1.9/64"	20 1147 043	43	1.11/16"	20 1147 057	57	2.1/4"
20 1147 016	16	5/8"	20 1147 030	30	1.3/16"	20 1147 044	44	1.47/64"	20 1147 058	58	2.9/32"
20 1147 017	17	43/64"	20 1147 031	31	1.7/32"	20 1147 045	45	1.49/64"	20 1147 059	59	2.21/64"
20 1147 018	18	45/64"	20 1147 032	32	1.17/64"	20 1147 046	46	1.13/16"	20 1147 060	60	2.23/64"
20 1147 019	19	3/4"	20 1147 033	33	1.19/64"	20 1147 047	☒ 47	1.27/32"	20 1147 061	61	2.13/32"
20 1147 020	20	25/32"	20 1147 034	34	1.11/32"	20 1147 048	48	1.57/64"	20 1147 062	62	2.7/16"
20 1147 021	21	53/64"	20 1147 035	35	1.3/8"	20 1147 049	49	1.59/64"	20 1147 063	63	2.31/64"
20 1147 022	22	55/64"	20 1147 036	36	1.27/64"	20 1147 050	50	1.31/32"	20 1147 064	64	2.33/64"
20 1147 023	23	29/32"	20 1147 037	37	1.29/64"	20 1147 051	51	2.1/64"	20 1147 065	65	2.9/16"
20 1147 024	24	15/16"	20 1147 038	38	1.1/2"	20 1147 052	52	2.3/64"			
20 1147 025	25	63/64"	20 1147 039	39	1.17/32"	20 1147 053	53	2.3/32"			

Größere Ø Schnitttiefe 30 mm siehe Art. 20 1130A + Adapter Fein Seite 594-597 · Größere Ø Schnitttiefe 55 mm siehe Art. 20 1141 + Adapter Fein Seite 598-601 · Achtung: Die Zollabmessungen entsprechen nicht exakt den mm Durchmessern.

Larger Ø in cutting depth 30 mm see Art. 20 1130A + adapter Fein page 594-597 · Larger Ø in cutting depth 55 mm see Art. 20 1141 + adapter Fein page 598-601 · Attention: The inch sizes do not correspond exactly to the mm diameters.

20 1147

HARD-LINE/40

ZUBEHÖR • ACCESSORIES

AUSWERFERSTIFTE • EJECTOR PINS



☒ 20 1388

Packnorm 2 Stk. · Packaging unit 2 pcs.

ADAPTER + PASSENDE AUSWERFERSTIFTE ADAPTER + SUITABLE EJECTOR PINS



☒ 20 1385



☒ 20 1318

Packnorm 2 Stk. · Packaging unit 2 pcs.

Weiteres Zubehör siehe Übersichtsseite 509
Further accessories see overview page 509

Ersatz-Innensechskantschrauben für alle Adapter siehe Seite 550
Spare allen screws for all adapters see page 550

20 1147

HARD-LINE/40

SETS / DISPLAYS Seite / Page 579

Wir bieten eine große Auswahl an Sets / Displays – Inhaltsvorschläge 20 1147 HARD-LINE40 – siehe Seite 579. Anderer Inhalt auf Wunsch möglich, durch individuell bestückbare Sets / Displays.

We offer a large selection of sets / displays – recommended content 20 1147 HARD-LINE40 – see page 579. Other content possible by individually equipped sets / displays.



Schnittdaten
Cutting data

Film
Movie



1487

Hartmetall-bestückter Kernbohrer, Fein Quick-In Schaft, Nutzlänge 55 mm
Carbide-tipped annular cutter, Fein Quick-In shank, drill depth 55 mm | 2"

HARD-LINE 55 20 1148

ANWENDUNG · APPLICATION

Stahl	Edelstahl	Grauguss	Alu	Kupfer, Messing, Zinn	Kunststoffe GFK/CFK	Hastelloy, Inconel, Exotische Materialien
Steel	Stainless	Grey cast iron	Alu	Copper, brass, tin	Plastics GRP/CRP	Hastelloy, Inconel, exotic materials
< 1400 N	> 900 N		> 10% Si			

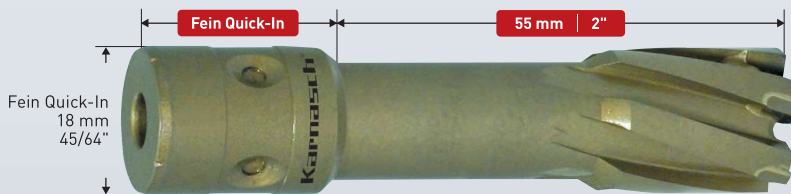

Art.	Ø mm	Ø Zoll Inch	Art.	Ø mm	Ø Zoll Inch	Art.	Ø mm	Ø Zoll Inch	Art.	Ø mm	Ø Zoll Inch
20 1148 012	12	15/32"	20 1148 026	26	1.1/32"	20 1148 040	40	1.37/64"	20 1148 055	55	2.11/64"
20 1148 013	13	33/64"	20 1148 027	27	1.1/16"	20 1148 041	41	1.39/64"	20 1148 056	56	2.13/64"
20 1148 014	14	35/64"	20 1148 028	28	1.7/64"	20 1148 043	43	1.11/16"	20 1148 057	57	2.1/4"
20 1148 015	15	19/32"	20 1148 029	29	1.9/64"	20 1148 044	44	1.47/64"	20 1148 058	58	2.9/32"
20 1148 016	16	5/8"	20 1148 030	30	1.3/16"	20 1148 045	45	1.49/64"	20 1148 059	59	2.21/64"
20 1148 017	17	43/64"	20 1148 031	31	1.7/32"	20 1148 046	46	1.13/16"	20 1148 060	60	2.23/64"
20 1148 018	18	45/64"	20 1148 032	32	1.17/64"	20 1148 047	47	1.27/32"			
20 1148 019	19	3/4"	20 1148 033	33	1.19/64"	20 1148 048	48	1.57/64"			
20 1148 020	20	25/32"	20 1148 034	34	1.11/32"	20 1148 049	49	1.59/64"			
20 1148 021	21	53/64"	20 1148 035	35	1.3/8"	20 1148 050	50	1.31/32"			
20 1148 022	22	55/64"	20 1148 036	36	1.27/64"	20 1148 051	51	2.1/64"			
20 1148 023	23	29/32"	20 1148 037	37	1.29/64"	20 1148 052	52	2.3/64"			
20 1148 024	24	15/16"	20 1148 038	38	1.1/2"	20 1148 053	53	2.3/32"			
20 1148 025	25	63/64"	20 1148 039	39	1.17/32"	20 1148 054	54	2.1/8"			

% Sonderpreis / Sale Artikel.
Lieferbar solange Vorrat.
Special price / sale article.
While stocks last.

Alternativartikel bis Ø 100 mm siehe Seite 598-601 Art. 20 1141A + Adapter Fein Art. 20 1443 -
Achtung: Die Zollabmessungen entsprechen nicht exakt den mm Durchmessern.

Alternative article up to Ø 100 mm see page 598-601 Art. 20 1141A + adapter Fein Art. 20 1443 -
Attention: The inch sizes do not correspond exactly to the mm diameters.

20 1148 HARD-LINE 55 ZUBEHÖR · ACCESSORIES

AUSWERFERSTIFTE · EJECTOR PINS

• **20 1154**

6,34 x 102 mm

Packnorm 2 Stk. · Packaging unit 2 pcs.

**ADAPTER + PASSENDE AUSWERFERSTIFTE
ADAPTER + SUITABLE EJECTOR PINS**

• **20 1385**

Weldon 19 mm 3/4" Fein Quick-In 18 mm

6,34 x 130 mm • **20 1160**

Packnorm 2 Stk. · Packaging unit 2 pcs.

Weiteres Zubehör siehe Übersichtsseite 509
Further accessories see overview page 509

Ersatz-Innensechskantschrauben für alle Adapter siehe Seite 550
Spare allen screws for all adapters see page 550

20 1148 HARD-LINE 55 SETS / DISPLAYS Seite / Page 580

Wir bieten eine große Auswahl an Sets / Displays – Inhaltsvorschläge 20 1148 HARD-LINE55 –
siehe Seite 580. Anderer Inhalt auf Wunsch möglich, durch individuell bestückbare Sets / Displays.

We offer a large selection of sets / displays – recommended content 20 1148 HARD-LINE55 –
see page 580. Other content possible by individually equipped sets / displays.



Schnittdaten Cutting data

Film Movie

1487 511

- 1
- 2
- 3
- 4
- 5
- 6
- 7
- 8
- 9
- 10

20 1190

HARD-LINE 80

Hartmetall-bestückter Kernbohrer, Fein Quick-In Schaft, Nutzlänge 80 mm
Carbide-tipped annular cutter, Fein Quick-In shank, drill depth 80 mm | 3"



ANWENDUNG • APPLICATION

Stahl Steel	Edelstahl Stainless	Grauguss Grey cast iron	Alu Alu	Kupfer, Messing, Zinn Copper, brass, tin	Kunststoffe GFK/CFK Plastics GRP/CRP	Hastelloy, Inconel, Exotische Materialien Hastelloy, Inconel, exotic materials
< 1400 N	> 900 N		> 10% Si			

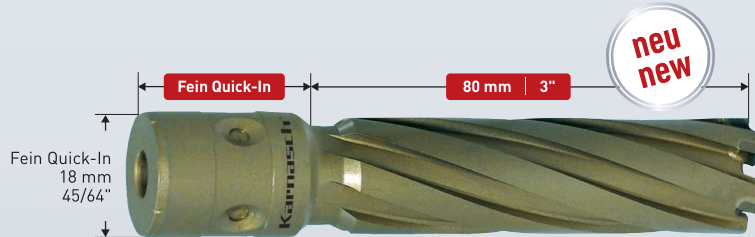

Art.	Ø mm	Ø Zoll Inch	Art.	Ø mm	Ø Zoll Inch	Art.	Ø mm	Ø Zoll Inch	Art.	Ø mm	Ø Zoll Inch
20 1190 014	• 14	35/64"	20 1190 020	• 20	25/32"	20 1190 026	• 26	1.1/32"	20 1190 040	• 40	1.37/64"
20 1190 015	• 15	19/32"	20 1190 021	• 21	53/64"	20 1190 027	• 27	1.1/16"			
20 1190 016	• 16	5/8"	20 1190 022	• 22	55/64"	20 1190 028	• 28	1.7/64"			
20 1190 017	• 17	43/64"	20 1190 023	• 23	29/32"	20 1190 029	• 29	1.9/64"			
20 1190 018	• 18	45/64"	20 1190 024	• 24	15/16"	20 1190 030	• 30	1.3/16"			
20 1190 019	• 19	3/4"	20 1190 025	• 25	63/64"	20 1190 032	• 32	1.17/64"			

Achtung: Die Zollabmessungen entsprechen nicht exakt den mm Durchmesser. ·
Attention: The inch sizes do not correspond exactly to the mm diameters.

20 1190

HARD-LINE 80

ZUBEHÖR • ACCESSORIES



AUSWERFERSTIFTE EJECTOR PINS

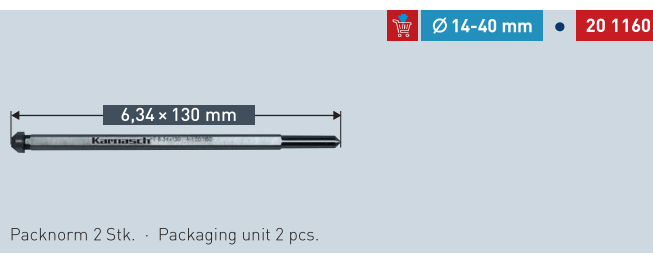

ADAPTER + PASSENDE AUSWERFERSTIFTE ADAPTER + SUITABLE EJECTOR PINS



Ersatz-Innensechskantschrauben für alle Adapter siehe Seite 550
Spare allen screws for all adapters see page 550

Schnittdaten
Cutting data

Film
Movie



1487



- 1
- 2
- 3
- 4
- 5
- 6
- 7
- 8
- 9
- 10



HERAUSRAGENDES SORTIMENT

EINES DER GRÖSSTEN WELTWEIT

OUTSTANDING RANGE
One of the largest in the world

1



2



3



4



5



6



7



8



9



10

Index

DAS KARNASCH PRODUKTSORTIMENT ONLINE! Nutzen Sie unseren Onlineshop und profitieren Sie von den speziellen Vorteilen für Onlineshop-Kunden.

THE KARNASCH PRODUCT RANGE ONLINE! Use our online shop and benefit from the special advantages for online shop customers.

 <https://karnasch.tools>

HSS-XE + DURABLU E BESCHICHTETE KERNBOHRER HSS-XE + DURABLU E-COATED ANNULAR CUTTERS



BLUE-DRILL LINE

Neben Hartmetall-bestückten Kernbohrern bieten beschichtete HSS-XE Kernbohrer das optimale Preis-Leistungs-Verhältnis.

Im harten Einsatz kann nur in den seltensten Fällen auf optimale Drehzahlen und Kühlung Rücksicht genommen werden. Die Karnasch DURABLU E-Beschichtung macht den Kernbohrer „Fehlerresistent“.

BLUE-DRILL LINE ist der am häufigsten verwendete Karnasch Kernbohrer. Der HSS-XE Bohrer mit dem besten Preis-Leistungs-Verhältnis für alle Stähle bis 40 Rockwell (HRC) Festigkeit sowie Edelstähle.

Carbide tipped annular cutters and coated HSS-XE cutters provide the optimal price-performance ratio.

Under hard field conditions only in the rarest cases optimum speed and cooling can be considered. The Karnasch DURABLU E-coating makes the annular cutter "error-resistant".

BLUE-DRILL LINE annular cutters are the most commonly used Karnasch cutters. This HSS-XE cutter is offering the best price-performance ratio for all steels up to a strength of 40 Rockwell (HRC) and stainless steel.

EIGENSCHAFTEN · PROPERTIES



Gefertigt aus hochlegiertem HSS-XE Spezialstahl. Für extreme Härte an den Zahnsitzen (bis 68 HRC). Somit hohe Verschleißfestigkeit und Standzeit.

Made of high-alloyed HSS-XE special steel. For extreme hardness at the tip of the tooth (up to 68 HRC). A high wear resistance and lifetime.

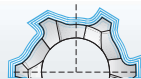

Unsere hochwertigsten Kernbohrer erhalten die einzigartige und patentierte DURABLU E-Beschichtung. Extreme Oberflächenhärte- und -glätte ergeben extreme Standzeiten auch unter nicht optimalen Arbeitsbedingungen wie „Über Kopf arbeiten“, Trockenbohrungen, u.s.w.

Our first-class annular cutters are equipped with the unique and patented DURABLU E-coating. Extreme surface hardness and sleekness yield extreme lifetimes even under non-optimum conditions like "overhead work", dry drilling, etc.



Nur wenige Hersteller sind in der Lage in Stufen gehärtete Kernbohrer zu fertigen. Für uns ist dies „Standard“. Dadurch erreichen wir extrem harte Zahnsitzen (68 HRC) und dennoch einen flexiblen Kernbohrer.

Only few manufacturers are capable of producing step-hardened annular cutters. For Karnasch this is "standard". Only this makes us produce extremely hard tooth tips (68 HRC) and yet a flexible annular cutter.

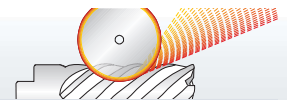

Aus dem vollen Material komplett geschliffen. Dieser Feinschliff erhöht die Zerspanleistung bei gleichzeitiger Reduzierung der Reibung. Für ein Mehr an Standzeit.

Completely made "FULLY GROUND". This refining increases the cutting ability while reducing friction at the same time. For an extended lifetime.

ANWENDUNG · APPLICATION

Stahl	Stahl	Stahl	Edelstahl	Edelstahl	Alu	Alu	Kupfer, Messing, Zinn	Kunststoffe GFK/CFK	Grauguss	Hastelloy, Inconel, Nimonic, Exotische Materialien	Hardox 400	Hardox 450
Steel	Steel	Steel	Stainless	Stainless	Alu	Alu	Copper, brass, tin	Plastics GRP/CRP	Grey cast iron	Hastelloy, Inconel, Nimonic, exotic materials	Hardox 400	Hardox 450
< 900 N	< 1100 N	< 1400 N	< 900 N	> 900 N	< 10% Si	> 10% Si						
✓	✓	✓	✓	✓	✓	✓	✓	✓	✓	✓	✓	✓

✓ OPTIMAL · OPTIMAL

✓ GUT · GOOD

✓ MÖGLICH · POSSIBLE

HSS-XE + DURABLUK BESCHICHTETE KERNBOHRER HSS-XE + DURABLUK-COATED ANNULAR CUTTERS

BLUE-DRILL LINE

Schnitttiefe · Drill depths

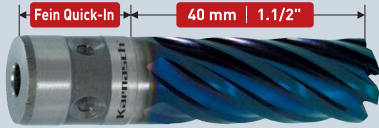

Ø mm

Ø Zoll/Inch

Art. / Type



12-60

15/32-
2.23/64"

20 1146

BLUE-DRILL LINE 40

516

HINWEISE · NOTES

Sie benötigen größere Schnitttiefen wie z. B. 80 mm oder 110 mm?

Arbeiten Sie mit Fein Adapter + Weldon Kernbohrer.
Siehe Art. 20 1650 (Schnitttiefe 80 mm) Seite 386
Siehe Art. 20 1660 (Schnitttiefe 110 mm) Seite 388

Require larger drill depths such as 80 mm or 110 mm?

Work with adapter Fein + Weldon annular cutters.
See Art. 20 1650 (cutting depth 80 mm) page 386
See Art. 20 1660 (cutting depth 110 mm) page 388



Packnorm 2 Stk.
Packaging unit 2 pcs.

Sie benötigen größere Durchmesser bis 100 mm?

Arbeiten Sie mit Fein Quick-In und Fein Quick-In Max Adaptern +
Power-Max Lochsagen siehe Seite 584

Require a larger diameter up to 100 mm?

Work with adapter Fein Quick-In or Fein Quick-In Max + our
Power-Max hole saws see page 584

FEIN QUICK-IN 18 mm

Passend für Maschinen · Suitable for machines
FEIN KBM 32 Q · KBM 50 Q · KBM 50 U · KBM 50 Auto · KBM 65 U

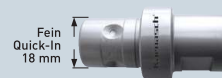

FEIN QUICK-IN MAX 32 mm 1.1/4"

Für Fein Maschine · For Fein machine
FEIN KBM 80 Quick-In Max

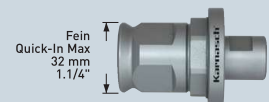

DRILL-LINE 30 PRO

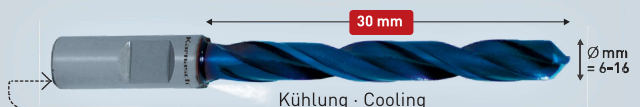

Sie benötigen kleinere Durchmesser wie:

6 mm, 8 mm, 9,8 mm, 10 mm, 11 mm?
Siehe Artikel 20 1430 Seite 446

Require a smaller diameter such as:

6 mm, 8 mm, 9,8 mm, 10 mm, 11 mm?
See article 20 1430 page 446



20 1146

BLUE-DRILL LINE / 40

HSS-XE + DURABLUe-beschichteter Kernbohrer, Fein Quick-In Schaft, Nutzlänge 40 mm
HSS-XE + DURABLUe-coated annular cutter, Fein Quick-In shank, drill depth 40 mm | 1.1/2"



ANWENDUNG • APPLICATION

Stahl	Edelstahl	Grauguss	Alu	Kupfer, Messing, Zinn	Kunststoffe GFK/CFK	Hardox 400, 450
Steel	Stainless	Grey cast iron	Alu	Copper, brass, tin	Plastics GRP/CRP	Hardox 400, 450
< 1100 N	< 900 N		> 10% Si			

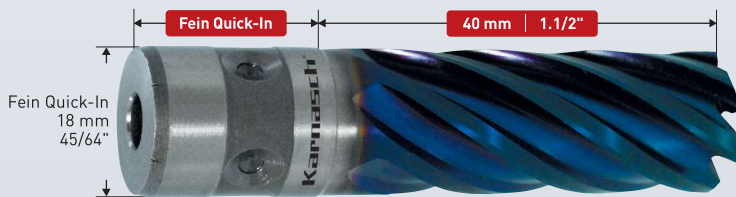

⚡ Sonderpreis / Sale Artikel. Lieferbar solange Vorrat.
Special price / sale article. While stocks last.

Art.	Ø mm	Ø Zoll Inch	Art.	Ø mm	Ø Zoll Inch	Art.	Ø mm	Ø Zoll Inch	Art.	Ø mm	Ø Zoll Inch
20 1146 012	• 12	15/32"	20 1146 024	• 24	15/16"	20 1146 036	• 36	1.27/64"	20 1146 051	⚡ 51	2.1/64"
20 1146 013	• 13	33/64"	20 1146 025	• 25	63/64"	20 1146 037	• 37	1.29/64"	20 1146 053	⚡ 53	2.3/32"
20 1146 014	• 14	35/64"	20 1146 026	• 26	1.1/32"	20 1146 038	• 38	1.1/2"	20 1146 054	⚡ 54	2.1/8"
20 1146 015	• 15	19/32"	20 1146 027	• 27	1.1/16"	20 1146 039	• 39	1.17/32"	20 1146 055	• 55	2.11/64"
20 1146 016	• 16	5/8"	20 1146 028	• 28	1.7/64"	20 1146 040	• 40	1.37/64"	20 1146 056	⚡ 56	2.13/64"
20 1146 017	• 17	43/64"	20 1146 029	• 29	1.9/64"	20 1146 041	⚡ 41	1.39/64"	20 1146 057	⚡ 57	2.1/4"
20 1146 018	• 18	45/64"	20 1146 030	• 30	1.3/16"	20 1146 043	⚡ 43	1.11/16"	20 1146 058	⚡ 58	2.9/32"
20 1146 019	• 19	3/4"	20 1146 031	• 31	1.7/32"	20 1146 045	• 45	1.49/64"	20 1146 059	⚡ 59	2.21/64"
20 1146 020	• 20	25/32"	20 1146 032	• 32	1.17/64"	20 1146 046	⚡ 46	1.13/16"	20 1146 060	• 60	2.23/64"
20 1146 021	• 21	53/64"	20 1146 033	• 33	1.19/64"	20 1146 047	⚡ 47	1.27/32"			
20 1146 022	• 22	55/64"	20 1146 034	• 34	1.11/32"	20 1146 049	⚡ 49	1.59/64"			
20 1146 023	• 23	29/32"	20 1146 035	• 35	1.3/8"	20 1146 050	• 50	1.31/32"			

Alternativartikel siehe Art. 20 1147 Seite 510 • **Achtung:** Die Zollabmessungen entsprechen nicht exakt den mm Durchmessern.
Alternative article see Art. 20 1147 page 510 • **Attention:** The inch sizes do not correspond exactly to the mm diameters.

20 1146

BLUE-DRILL LINE / 40

ZUBEHÖR • ACCESSORIES

AUSWERFERSTIFTE • EJECTOR PINS

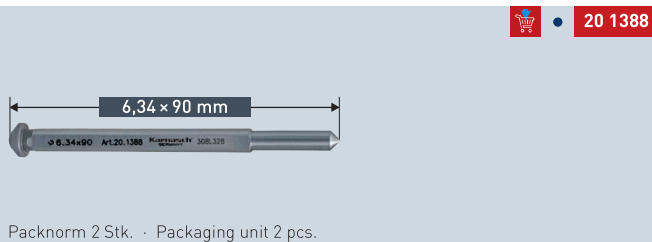

ADAPTER + PASSENDE AUSWERFERSTIFTE ADAPTER + SUITABLE EJECTOR PINS

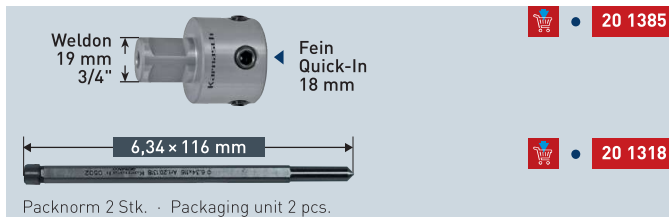

Weiteres Zubehör siehe Übersichtsseite 509
Further accessories see overview page 509

Ersatz-Innensechskantschrauben für alle Adapter siehe Seite 550
Spare allen screws for all adapters see page 550

20 1146

BLUE-DRILL LINE / 40

SETS / DISPLAYS Seite / Page 581

Wir bieten eine große Auswahl an Sets / Displays – Inhaltsvorschläge 20 1146 BLUE-DRILL LINE40 – siehe Seite 581. Anderer Inhalt auf Wunsch möglich, durch individuell bestückbare Sets / Displays.
We offer a large selection of sets / displays – recommended content 20 1146 BLUE-DRILL LINE40 – see page 581. Other content possible by individually equipped sets / displays.



Schnittdaten
Cutting data

Film
Movie



1488

Qualitätsprodukte für die Metallbearbeitung.
Quality products for metalworking.

PREMIUM-QUALITÄT IN JEDEM TEIL VON WERKZEUG BIS MASCHINE

Premium quality in all components,
from tools to machinery



DAS KARNASCH PRODUKTSORTIMENT ONLINE! Nutzen Sie unseren Onlineshop und profitieren Sie von den speziellen Vorteilen für Onlineshop-Kunden.

THE KARNASCH PRODUCT RANGE ONLINE! Use our onlineshop and benefit from the special advantages for onlineshop customers.

 <https://karnasch.tools>

1



2



3



4



5



6



7



8



9



10



Index

HSS-XE KERNBOHRER HSS-XE ANNULAR CUTTERS



GOLD-DRILL LINE

Karnasch GOLD-DRILL LINE Kernbohrer sind die am meisten verwendeten nicht beschichteten HSS-XE Kernbohrer.

Durch spezial GOLD-TECH Oberflächenbehandlung + Vollschliff + HSS-XE Spezialstahl hervorragend zum Bohren in Stähle bis 40 Rockwell (HRC) und sogar geeignet für Edelstähle.

Karnasch GOLD-DRILL LINE annular cutters are the most commonly used non-coated HSS-XE annular cutter.

With special surface treatment GOLD-TECH + FULLY GROUND + special steel HSS-XE are ideal for drilling in steel up to a strength of 40 Rockwell (HRC) and even suitable for stainless steels.

EIGENSCHAFTEN · PROPERTIES



Gefertigt aus hochlegiertem HSS-XE Spezialstahl. Für extreme Härte an den Zahnspitzen (bis 68 HRC). Somit hohe Verschleißfestigkeit und Standzeit.

Made of high-alloyed HSS-XE special steel. For extreme hardness at the tip of the tooth (up to 68 HRC). A high wear resistance and lifetime.



Gold-Tech Oberflächenbehandlung. Die Spezialbehandlung für höhere Standzeiten

Gold-Tech surface treatment. The special treatment for longer lifetimes.



Nur wenige Hersteller sind in der Lage in Stufen gehärtete Kernbohrer zu fertigen. Für uns ist dies „Standard“. Dadurch erreichen wir extrem harte Zahnspitzen (68 HRC) und dennoch einen flexiblen Kernbohrer.

Only few manufacturers are capable of producing step-hardened annular cutters. For Karnasch this is "standard". Only this makes us produce extremely hard tooth tips (68 HRC) and yet a flexible annular cutter.

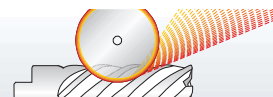

Aus dem vollen Material komplett geschliffen. Dieser Feinschliff erhöht die Zerspanleistung bei gleichzeitiger Reduzierung der Reibung. Für ein Mehr an Standzeit.

Completely made "FULLY GROUND". This refining increases the cutting ability while reducing friction at the same time. For an extended lifetime.

ANWENDUNG · APPLICATION

Stahl	Stahl	Stahl	Edelstahl	Alu	Alu	Kupfer, Messing, Zinn	Kunststoffe GFK/CFK	Hardox 400	Hardox 450
Steel	Steel	Steel	Stainless	Alu	Alu	Copper, brass, tin	Plastics GRP/CRP	Hardox 400	Hardox 450
< 750 N	< 900 N	< 1100 N	< 900 N	< 10% Si	> 10% Si				
✓	✓	✓	✓	✓	✓	✓	✓	✓	✓

✓ OPTIMAL · OPTIMAL

✓ GUT · GOOD

✓ MÖGLICH · POSSIBLE

HSS-XE KERNBOHRER HSS-XE ANNULAR CUTTERS

GOLD-DRILL LINE

Schnitttiefe · Drill depths



Ø mm

Ø Zoll/Inch

Art. / Type



12-60

15/32-
2.23/64"

20 1146U

GOLD-DRILL LINE / 40

520

HINWEISE · NOTES

Sie benötigen größere Schnitttiefen wie z. B. 80 mm oder 110 mm?

Arbeiten Sie mit Fein Adapter + Weldon Kernbohrer.
Siehe Art. 20 1650 (Schnitttiefe 80 mm) Seite 386
Siehe Art. 20 1660 (Schnitttiefe 110 mm) Seite 388

Require larger drill depths such as 80 mm or 110 mm?

Work with adapter Fein + Weldon annular cutters.
See Art. 20 1650 (cutting depth 80 mm) page 386
See Art. 20 1660 (cutting depth 110 mm) page 388



Packnorm 2 Stk.
Packaging unit 2 pcs.

Sie benötigen größere Durchmesser bis 100 mm?

Arbeiten Sie mit Fein Quick-In und Fein Quick-In Max Adaptern +
Power-Max Lochsagen siehe Seite 584

Require a larger diameter up to 100 mm?

Work with adapter Fein Quick-In or Fein Quick-In Max + our
Power-Max hole saws see page 584

FEIN QUICK-IN 18 mm

Passend für Maschinen · Suitable for machines
FEIN KBM 32 Q · KBM 50 Q · KBM 50 U · KBM 50 Auto · KBM 65 U

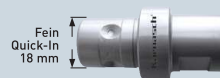

FEIN QUICK-IN MAX 32 mm 1.1/4"

Für Fein Maschine · For Fein machine
FEIN KBM 80 Quick-In Max

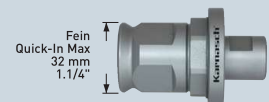

DRILL-LINE 30 PRO



Sie benötigen kleinere Durchmesser wie:

6 mm, 8 mm, 9,8 mm, 10 mm, 11 mm?
Siehe Artikel 20 1430 Seite 446

Require a smaller diameter such as:

6 mm, 8 mm, 9,8 mm, 10 mm, 11 mm?
See article 20 1430 page 446

- 1
- 2
- 3
- 4
- 5
- 6
- 7
- 8
- 9
- 10

Index

20 1146U

GOLD-DRILL LINE / 40

HSS-XE Kernbohrer, Fein Quick-In Schaft, Nutzlänge 40 mm
HSS-XE annular cutter, Fein Quick-In shank, drill depth 40 mm | 1.1/2"



ANWENDUNG • APPLICATION

Stahl	Edelstahl	Grauguss	Alu	Kupfer, Messing, Zinn	Kunststoffe GFK/CFK	Hardox 400, 450
Steel	Stainless	Grey cast iron	Alu	Copper, brass, tin	Plastics GRP/CRP	Hardox 400, 450
< 900 N	< 900 N		< 10% Si			

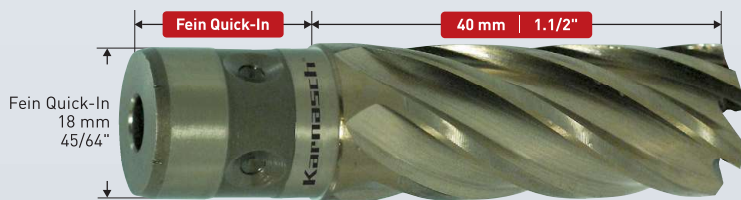

☞ Sonderpreis / Sale Artikel. Lieferbar solange Vorrat.
Special price / sale article. While stocks last.

Art.	Ø mm	Ø Zoll Inch	Art.	Ø mm	Ø Zoll Inch	Art.	Ø mm	Ø Zoll Inch	Art.	Ø mm	Ø Zoll Inch
20 1146u 012	• 12	1/2"	20 1146u 024	• 24	1 1/2"	20 1146u 036	• 36	1.27/64"	20 1146u 054	☞ 54	2.1/8"
20 1146u 013	• 13	33/64"	20 1146u 025	• 25	63/64"	20 1146u 037	• 37	1.29/64"	20 1146u 055	• 55	2.11/64"
20 1146u 014	• 14	35/64"	20 1146u 026	• 26	1.1/32"	20 1146u 038	• 38	1.1/2"	20 1146u 056	☞ 56	2.13/64"
20 1146u 015	• 15	19/32"	20 1146u 027	• 27	1.1/16"	20 1146u 039	• 39	1.17/32"	20 1146u 057	☞ 57	2.1/4"
20 1146u 016	• 16	5/8"	20 1146u 028	• 28	1.7/64"	20 1146u 040	• 40	1.37/64"	20 1146u 058	☞ 58	2.9/32"
20 1146u 017	• 17	43/64"	20 1146u 029	• 29	1.9/64"	20 1146u 045	• 45	1.49/64"	20 1146u 059	☞ 59	2.21/64"
20 1146u 018	• 18	45/64"	20 1146u 030	• 30	1.3/16"	20 1146u 046	☞ 46	1.13/16"	20 1146u 060	• 60	2.23/64"
20 1146u 019	• 19	3/4"	20 1146u 031	• 31	1.7/32"	20 1146u 049	☞ 49	1.59/64"			
20 1146u 020	• 20	25/32"	20 1146u 032	• 32	1.17/64"	20 1146u 050	• 50	1.31/32"			
20 1146u 021	• 21	53/64"	20 1146u 033	• 33	1.19/64"	20 1146u 051	☞ 51	2.1/64"			
20 1146u 022	• 22	55/64"	20 1146u 034	• 34	1.11/32"	20 1146u 052	☞ 52	2.3/64"			
20 1146u 023	• 23	29/32"	20 1146u 035	• 35	1.3/8"	20 1146u 053	☞ 53	2.3/32"			

Alternativartikel siehe Art. 20 1147 Seite 510 • **Achtung:** Die Zollabmessungen entsprechen nicht exakt den mm Durchmessern.
Alternative article see Art. 20 1147 page 510 • **Attention:** The inch sizes do not correspond exactly to the mm diameters.

20 1146U

GOLD-DRILL LINE / 40

ZUBEHÖR • ACCESSORIES

AUSWERFERSTIFTE • EJECTOR PINS

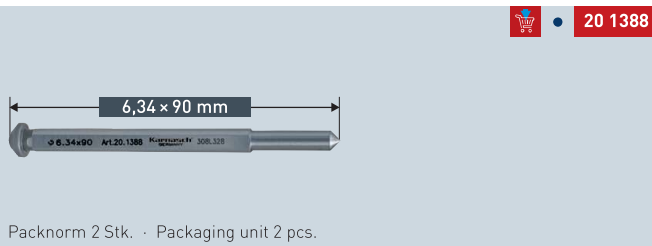

• 20 1388

6,34 × 90 mm

Packnorm 2 Stk. • Packaging unit 2 pcs.

ADAPTER + PASSENDE AUSWERFERSTIFTE ADAPTER + SUITABLE EJECTOR PINS

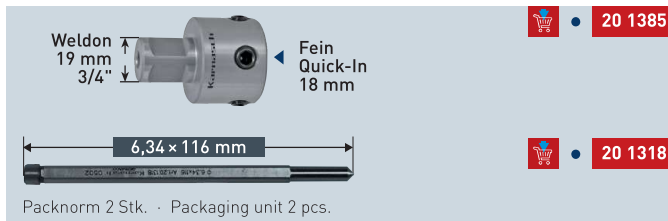

• 20 1385

Weldon 19 mm 3/4"

Fein Quick-In 18 mm

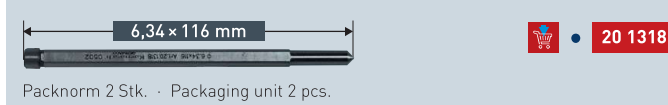

• 20 1318

6,34 × 116 mm

Packnorm 2 Stk. • Packaging unit 2 pcs.

Weiteres Zubehör siehe Übersichtsseite 509
Further accessories see overview page 509

Ersatz-Innensechskantschrauben für alle Adapter siehe Seite 550
Spare allen screws for all adapters see page 550

20 1146U

GOLD-DRILL LINE / 40



SETS / DISPLAYS Seite / Page 582

Wir bieten eine große Auswahl an Sets / Displays – Inhaltsvorschläge 20 1146U GOLD-DRILL LINE40 – siehe Seite 582. Anderer Inhalt auf Wunsch möglich, durch individuell bestückbare Sets / Displays.
We offer a large selection of sets / displays – recommended content 20 1146U GOLD-DRILL LINE40 – see page 582. Other content possible by individually equipped sets / displays.



Schnittdaten Cutting data

Film Movie

1488

SCHIENENBOHRER

RAILWAY CUTTERS

RAIL-LINE

Ein komplettes Programm von $\varnothing 6-60$ mm zum Bohren in Schienen.

A complete range of $\varnothing 6-60$ mm for drilling in rails.

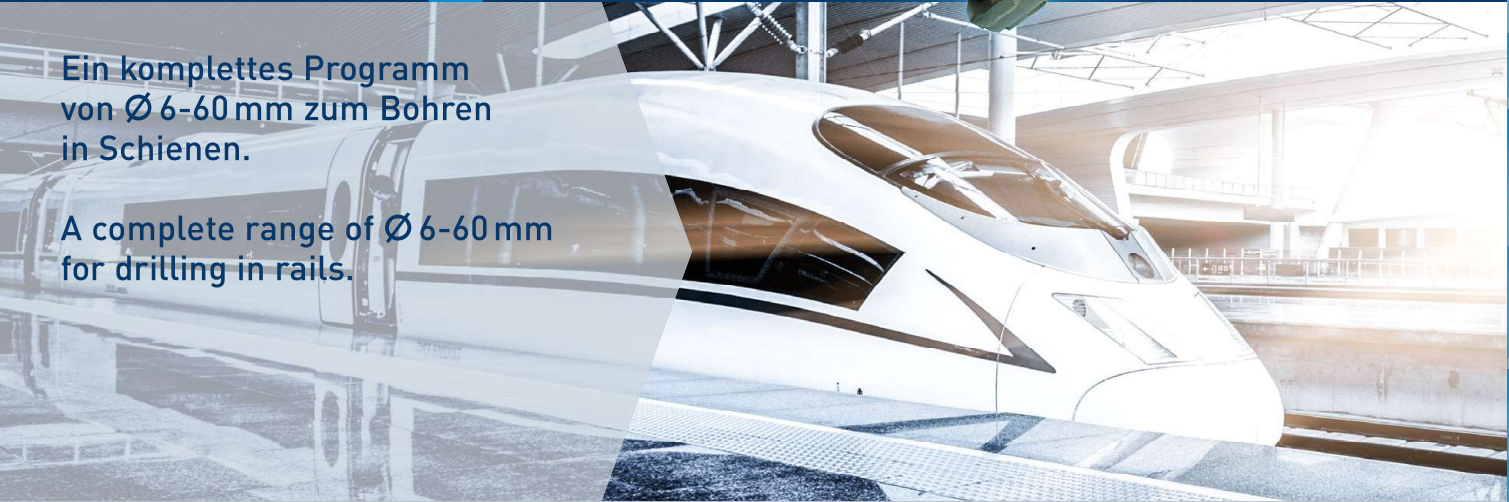

RAIL-LINE PRO

Kernbohrer Hartmetall-bestückt. Mehr als 200 Bohrungen möglich

Annular cutter tungsten carbide tipped. More than 200 holes possible



20 1680
20 1690

RAIL-LINE

Kernbohrer Hartmetall-bestückt. Mehr als 100 Bohrungen möglich

Annular cutter tungsten carbide tipped. More than 100 holes possible



20 1306
20 1309

BLUE-DRILL LINE RAIL PRO

Kernbohrer aus Pulverstahl + DURABLU beschichtet. Mehr als 100 Bohrungen möglich

Annular cutter powder steel + DURABLU-coated. More than 100 holes possible



20 1284
20 1317

SILVER-DRILL LINE RAIL

Kernbohrer aus HSS-XE Spezialstahl. Mehr als 60 Bohrungen möglich

Annular cutter made of HSS-XE special steel. More than 60 holes possible



20 1460
20 1480

DRILL-LINE RAIL PRO

Spiralbohrer aus Pulverstahl + DURABLU beschichtet. Mehr als 100 Bohrungen möglich

Twist drills made of powder steel + DURABLU-coated. More than 100 holes possible



20 1430
20 1465

DRILL-LINE RAIL

Spiralbohrer aus HSS-XE Spezialstahl. Mehr als 60 Bohrungen möglich

Twist drills made of HSS-XE special steel. More than 60 holes possible



20 1710

522-525

526-529

530-533

534-537

538-539

540

- 1
- 2
- 3
- 4
- 5
- 6
- 7
- 8
- 9
- 10

Index

20 1680

RAIL-LINE 25 PRO

Hartmetall-bestückter Kernbohrer, Weldonschaft, Nutzlänge 25 mm
Carbide-tipped annular cutter, Weldon shank, drill depth 25 mm | 1"



ANWENDUNG • APPLICATION



Für alle Schienentypen bis 1100 N (UIC 60).

Schienen
Rails

For all rail types up to 1100 N (UIC 60).

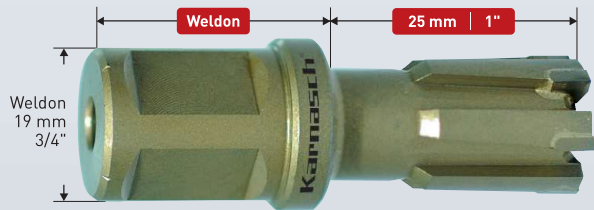

Art.	Ø mm	Ø Zoll Inch	Art.	Ø mm	Ø Zoll Inch	Art.	Ø mm	Ø Zoll Inch	Art.	Ø mm	Ø Zoll Inch
20 1680 014	• 14	35/64"	20 1680 022	• 22	55/64"	20 1680 030	• 30	1.3/16"	20 1680 038	• 38	1.1/2"
20 1680 015	• 15	19/32"	20 1680 023	• 23	29/32"	20 1680 031	• 31	1.7/32"	20 1680 039	• 39	1.17/32"
20 1680 016	• 16	5/8"	20 1680 024	• 24	15/16"	20 1680 032	• 32	1.17/64"	20 1680 040	• 40	1.37/64"
20 1680 017	• 17	43/64"	20 1680 025	• 25	63/64"	20 1680 033	• 33	1.19/64"			
20 1680 018	• 18	45/64"	20 1680 026	• 26	1.1/32"	20 1680 034	• 34	1.11/32"			
20 1680 019	• 19	3/4"	20 1680 027	• 27	1.1/16"	20 1680 035	• 35	1.3/8"			
20 1680 020	• 20	25/32"	20 1680 028	• 28	1.7/64"	20 1680 036	• 36	1.27/64"			
20 1680 021	• 21	53/64"	20 1680 029	• 29	1.9/64"	20 1680 037	• 37	1.29/64"			

Größere Ø siehe Art. 20 1690 Seite 524 • **Achtung:** Die Zollabmessungen entsprechen nicht exakt den mm Durchmesser.
Larger Ø see Art. 20 1690 page 524 • **Attention:** The inch sizes do not correspond exactly to the mm diameters.

20 1680

RAIL-LINE 25 PRO

ZUBEHÖR • ACCESSORIES



AUSWERFERSTIFTE • EJECTOR PINS



Ø 12-40 mm • 20 1261

Packnorm 2 Stk. • Packaging unit 2 pcs.

EIGENSCHAFTEN • PROPERTIES



Karnasch RAIL-LINE-PRO Kernbohrer werden mit konischer Spirale gefertigt für sauberen Spanfluss und höchste Zerspanleistung.

Karnasch RAIL-LINE-PRO carbide tipped annular cutters are made with a conical helix for clean chip flow and highest cutting ability.



Karnasch RAIL-LINE-PRO Kernbohrer kommen mit optimiertem Hartmetall zum bohren in schwierigste Schienenstähle (z.B. UIC 60)

Karnasch RAIL-LINE-PRO annular cutters come with optimized carbide teeth for excellent results drilling in most difficult rail steel (e.g. UIC 60)



Karnasch RAIL-LINE-PRO Kernbohrer sind in einer aufwendigen Vor-Mittel-Nachscheider-Geometrie gefertigt. Dies ergibt: ratterfreies, ruhiges und leichtes Zerspanen mit höchsten Standzeiten. **Die Schnittwinkel sind zum Bohren von Schienen optimiert.**

Karnasch RAIL-LINE-PRO annular cutters are made in an elaborate pre-/ intermediate-/ after-cutting geometry. This results in: clatter-free, silent and easy cutting with highest lifetimes. **The cutting angles are optimized for drilling in rails.**

TOOLTIPP

Unser bestes Modell zum Bohren schwierigster Schienenstähle.
Our best model for drilling in the most difficult types of rail steel.



Schnittdaten
Cutting data

Film
Movie



1492

Zubehör für Hartmetall-bestückte Kernbohrer, Weldonschaft, Nutzlänge 25 mm
Accessories for carbide-tipped annular cutter, Weldon shank, drill depth 25 mm | 1"

RAIL-LINE 25 PRO 20 1680

SETS / DISPLAYS

20 1344



max. 44 Stück / Pieces

20 1138

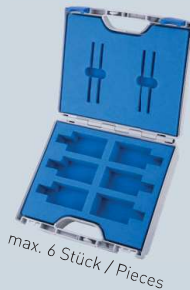

max. 6 Stück / Pieces

20 1132

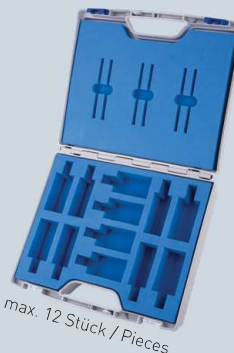

max. 12 Stück / Pieces

20 1139



max. 50 Stück / Pieces

Sie möchten Ihren Inhalt selbst aussuchen? Kein Problem. Kontaktieren Sie uns und wir stellen Ihr Wunsch-Set oder Wunsch-Display zusammen.

Would you like to select your own contents? No Problem. Contact us and we create your individual set or display.

20 1432



Packnorm 2 Stk. - Packaging unit 2 pcs.

20 1271

VERLÄNGERUNGEN + PASSENDE AUSWERFERSTIFTE
EXTENSIONS + SUITABLE EJECTOR PINS

20 1387

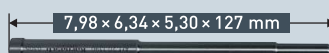

Packnorm 2 Stk. - Packaging unit 2 pcs.

20 1433

20 1402

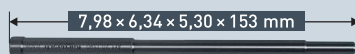

Packnorm 2 Stk. - Packaging unit 2 pcs.

20 1396

20 1417

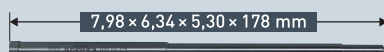

Packnorm 2 Stk. - Packaging unit 2 pcs.

20 1411

ADAPTER + PASSENDE AUSWERFERSTIFTE
ADAPTER + SUITABLE EJECTOR PINS

20 1263



Packnorm 2 Stk. - Packaging unit 2 pcs.

20 1271

20 1311

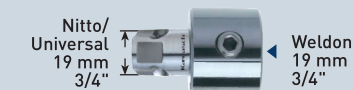

Packnorm 2 Stk. - Packaging unit 2 pcs.

20 1271

21 0048

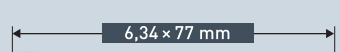

Packnorm 2 Stk. - Packaging unit 2 pcs.

20 1261

Ersatz-Innensechskantschrauben für alle Verlängerungen siehe Seite 550
Spare allen screws for all extensions see page 550

Weiteres Zubehör siehe Übersichtsseite 509
Further accessories see overview page 509

Spezialverlängerungen + passender Auswerferstift von 25 mm auf 50 mm.
Somit kann in vielen Fällen auf die längeren Kernbohrer RAIL-LINE 50 PRO verzichtet werden.

Special extension + suitable ejector pin from 25 mm to 50 mm. This allows to renounce the longer annular cutter RAIL-LINE 50 PRO.

Ersatz-Innensechskantschrauben für alle Adapter siehe Seite 550
Spare allen screws for all adapters see page 550



20 1690

RAIL-LINE 50 PRO

Hartmetall-bestückter Kernbohrer, Weldonschaft, Nutzlänge 50 mm
Carbide-tipped annular cutter, Weldon shank, drill depth 50 mm | 2"



ANWENDUNG • APPLICATION

Für alle Schienentypen bis 1100 N (UIC 60).
For all rail types up to 1100 N (UIC 60).

Schienen
Rails

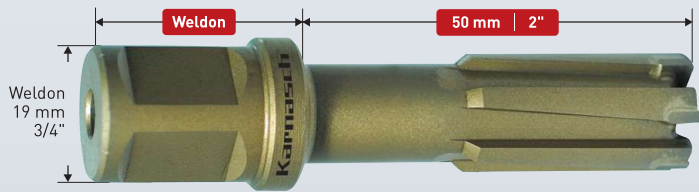

☞ Sonderpreis / Sale Artikel. Lieferbar solange Vorrat.
Special price / sale article. While stocks last.

Art.	Ø mm	Ø Zoll Inch	Art.	Ø mm	Ø Zoll Inch	Art.	Ø mm	Ø Zoll Inch	Art.	Ø mm	Ø Zoll Inch
20 1690 014	• 14	35/64"	20 1690 026	• 26	1.1/32"	20 1690 038	• 38	1.1/2"	20 1690 050	• 50	1.31/32"
20 1690 015	• 15	19/32"	20 1690 027	• 27	1.1/16"	20 1690 039	• 39	1.17/32"	20 1690 051	• 51	2.1/64"
20 1690 016	• 16	5/8"	20 1690 028	• 28	1.7/64"	20 1690 040	• 40	1.37/64"	20 1690 052	• 52	2.3/64"
20 1690 017	• 17	43/64"	20 1690 029	• 29	1.9/64"	20 1690 041	• 41	1.39/64"	20 1690 053	☞ 53	2.3/32"
20 1690 018	• 18	45/64"	20 1690 030	• 30	1.3/16"	20 1690 042	• 42	1.21/32"	20 1690 054	• 54	2.1/8"
20 1690 019	• 19	3/4"	20 1690 031	• 31	1.7/32"	20 1690 043	• 43	1.11/16"	20 1690 055	• 55	2.11/64"
20 1690 020	• 20	25/32"	20 1690 032	• 32	1.17/64"	20 1690 044	• 44	1.47/64"	20 1690 056	• 56	2.13/64"
20 1690 021	• 21	53/64"	20 1690 033	• 33	1.19/64"	20 1690 045	• 45	1.49/64"	20 1690 057	☞ 57	2.1/4"
20 1690 022	• 22	55/64"	20 1690 034	• 34	1.11/32"	20 1690 046	• 46	1.13/16"	20 1690 058	☞ 58	2.9/32"
20 1690 023	• 23	29/32"	20 1690 035	• 35	1.3/8"	20 1690 047	• 47	1.27/32"	20 1690 059	• 59	2.21/64"
20 1690 024	• 24	15/16"	20 1690 036	• 36	1.27/64"	20 1690 048	• 48	1.57/64"	20 1690 060	• 60	2.23/64"
20 1690 025	• 25	63/64"	20 1690 037	• 37	1.29/64"	20 1690 049	• 49	1.59/64"			

Achtung: Die Zollabmessungen entsprechen nicht exakt den mm Durchmesser. **Attention:** The inch sizes do not correspond exactly to the mm diameters.

20 1690

RAIL-LINE 50 PRO

ZUBEHÖR • ACCESSORIES



AUSWERFERSTIFTE • EJECTOR PINS

Ø 14-60 mm • 20 1271

6,34 x 102 mm

Packnorm 2 Stk. • Packaging unit 2 pcs.

EIGENSCHAFTEN • PROPERTIES



Karnasch RAIL-LINE-PRO Kernbohrer werden mit konischer Spirale gefertigt für sauberen Spanfluss und höchste Zerspanleistung.

Karnasch RAIL-LINE-PRO carbide tipped annular cutters are made with a conical helix for clean chip flow and highest cutting ability.



Karnasch RAIL-LINE-PRO Kernbohrer kommen mit optimiertem Hartmetall zum bohren in schwierigste Schienenstähle (z.B. UIC 60)

Karnasch RAIL-LINE-PRO annular cutters come with optimized carbide teeth for excellent results drilling in most difficult rail steel (e.g. UIC 60)



Karnasch RAIL-LINE-PRO Kernbohrer sind in einer aufwendigen Vor-Mittel-Nachscheider-Geometrie gefertigt. Dies ergibt: ratterfreies, ruhiges und leichtes Zerspanen mit höchsten Standzeiten. **Die Schnittwinkel sind zum Bohren von Schienen optimiert.**

Karnasch RAIL-LINE-PRO annular cutters are made in an elaborate pre-/ intermediate-/ after-cutting geometry. This results in: clatter-free, silent and easy cutting with highest lifetimes. **The cutting angles are optimized for drilling in rails.**

TOOLTIPP

Unser bestes Modell zum Bohren schwierigster Schienenstähle.
Our best model for drilling in the most difficult types of rail steel.



Schnittdaten
Cutting data

Film
Movie



1492



- 1
- 2
- 3
- 4
- 5
- 6
- 7
- 8
- 9
- 10

Zubehör für Hartmetall-bestückte Kernbohrer, Weldonschaft, Nutzlänge 50 mm
 Accessories for carbide-tipped annular cutter, Weldon shank, drill depth 50 mm | 2"

RAIL-LINE 50 PRO 20 1690

SETS / DISPLAYS

• 20 1344 • 20 1138 • 20 1132 • 20 1139



max. 44 Stück / Pieces

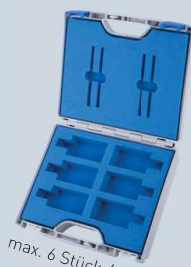

max. 6 Stück / Pieces

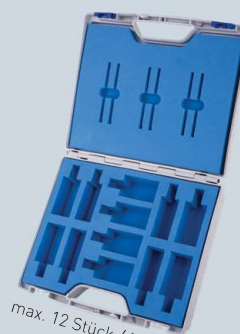

max. 12 Stück / Pieces



max. 50 Stück / Pieces

Sie möchten Ihren Inhalt selbst aussuchen? Kein Problem. Kontaktieren Sie uns und wir stellen Ihr Wunsch-Set oder Wunsch-Display zusammen.

Would you like to select your own contents? No Problem. Contact us and we create your individual set or display.

**ADAPTER + PASSENDE AUSWERFERSTIFTE
 ADAPTER + SUITABLE EJECTOR PINS**



• 20 1263



• 20 1160

Packnorm 2 Stk. - Packaging unit 2 pcs.



• 20 1311



• 20 1160

Packnorm 2 Stk. - Packaging unit 2 pcs.



• 21 0048



• 20 1271

Packnorm 2 Stk. - Packaging unit 2 pcs.

Ersatz-Innensechskantschrauben für alle Adapter siehe Seite 550
 Spare allen screws for all adapters see page 550

**VERLÄNGERUNGEN + PASSENDE AUSWERFERSTIFTE
 EXTENSIONS + SUITABLE EJECTOR PINS**



• 20 1387

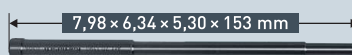

• 20 1396

Packnorm 2 Stk. - Packaging unit 2 pcs.



• 20 1402



• 20 1411

Packnorm 2 Stk. - Packaging unit 2 pcs.



• 20 1417



• 20 1426

Packnorm 2 Stk. - Packaging unit 2 pcs.

Ersatz-Innensechskantschrauben für alle Verlängerungen siehe Seite 550
 Spare allen screws for all extensions see page 550

Weiteres Zubehör siehe Übersichtsseite 509
 Further accessories see overview page 509



20 1306

RAIL-LINE 30

Hartmetall-bestückter Kernbohrer, Weldonschaft, Nutzlänge 30 mm
Carbide-tipped annular cutter, Weldon shank, drill depth 30 mm | 1"



ANWENDUNG • APPLICATION

Für alle Schienentypen bis 1100 N (UIC 60).
For all rail types up to 1100 N (UIC 60).

Schienen
Rails

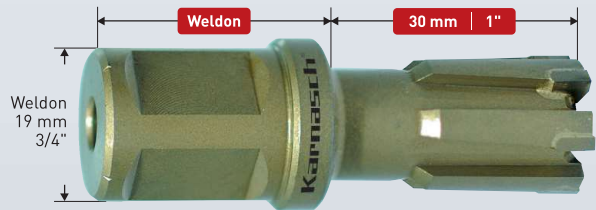

Art.	Ø mm	Ø Zoll Inch	Art.	Ø mm	Ø Zoll Inch	Art.	Ø mm	Ø Zoll Inch	Art.	Ø mm	Ø Zoll Inch
20 1306 018	• 18	45/64"	20 1306 024	• 24	15/16"	20 1306 030	• 30	1.3/16"	20 1306 036	• 36	1.27/64"
20 1306 019	• 19	3/4"	20 1306 025	• 25	63/64"	20 1306 031	• 31	1.7/32"	20 1306 038	• 38	1.1/2"
20 1306 020	• 20	25/32"	20 1306 026	• 26	1.1/32"	20 1306 032	• 32	1.17/64"			
20 1306 021	• 21	53/64"	20 1306 027	• 27	1.1/16"	20 1306 033	• 33	1.19/64"			
20 1306 022	• 22	55/64"	20 1306 028	• 28	1.7/64"	20 1306 034	• 34	1.11/32"			
20 1306 023	• 23	29/32"	20 1306 029	• 29	1.9/64"	20 1306 035	• 35	1.3/8"			

Achtung: Die Zollabmessungen entsprechen nicht exakt den mm Durchmesser.
Attention: The inch sizes do not correspond exactly to the mm diameters.

20 1306

RAIL-LINE 30

ZUBEHÖR • ACCESSORIES



AUSWERFERSTIFTE • EJECTOR PINS



• 20 1261

Packnorm 2 Stk. • Packaging unit 2 pcs.

EIGENSCHAFTEN • PROPERTIES

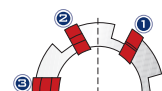

Karnasch Hartmetall-bestückte Kernbohrer (HARD-LINE) werden mit konischer Spirale gefertigt für: Sauberen Spanfluss und höchste Zerspanleistung auch bei schwierigen Materialien.

Karnasch carbide tipped annular cutters (HARD-LINE) are made with a conical helix for: clean chip flow and highest cutting ability even with difficult materials.

Karnasch Hartmetall-bestückte Kernbohrer (HARD-LINE) werden ausschließlich mit Sandvik Hartmetallzähnen bestückt. Wir meinen: Nur das beste Hartmetall ist gut genug für Karnasch Kernbohrer.

Karnasch carbide tipped annular cutters (HARD-LINE) are exclusively equipped with Sandvik carbide teeth. Our opinion is: Only the best carbide is good enough for Karnasch annular cutters.

Karnasch Hartmetall-bestückte Kernbohrer (HARD-LINE) sind in einer aufwendigen Vor-Mittel-Nachsneider-Geometrie gefertigt. Dies ergibt: ratterfreies, ruhiges und leichtes Zerspannen mit höchsten Standzeiten. **Die Schnittwinkel sind zum Bohren von Schienen optimiert.**

Karnasch carbide tipped annular cutters (HARD-LINE) are made in an elaborate pre-/intermediate-/after-cutting geometry. This results in: clatter-free, silent and easy cutting with highest lifetimes. **The cutting angles are optimized for drilling in rails.**

Schnittdaten
Cutting data

Film
Movie



1487



Zubehör für Hartmetall-bestückte Kernbohrer, Weldonschaft, Nutzlänge 30 mm
 Accessories for carbide-tipped annular cutter, Weldon shank, drill depth 30 mm | 1"

RAIL-LINE 730 20 1306

SETS / DISPLAYS

• 20 1344



max. 44 Stück / Pieces

• 20 1138

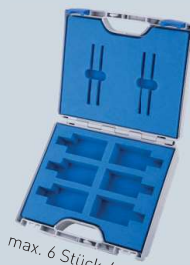

max. 6 Stück / Pieces

• 20 1132

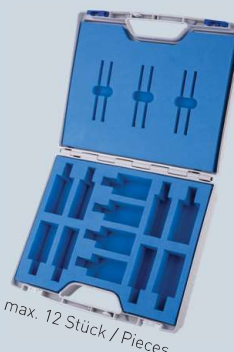

max. 12 Stück / Pieces

• 20 1139



max. 50 Stück / Pieces

Sie möchten Ihren Inhalt selbst aussuchen? Kein Problem. Kontaktieren Sie uns und wir stellen Ihr Wunsch-Set oder Wunsch-Display zusammen.

Would you like to select your own contents? No Problem. Contact us and we create your individual set or display.

• 20 1432



Packnorm 2 Stk. - Packaging unit 2 pcs.

• 20 1271

VERLÄNGERUNGEN + PASSENDE AUSWERFERSTIFTE
EXTENSIONS + SUITABLE EJECTOR PINS

• 20 1387

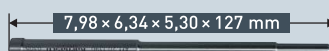

Packnorm 2 Stk. - Packaging unit 2 pcs.

• 20 1433

• 20 1402

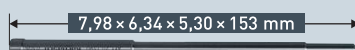

Packnorm 2 Stk. - Packaging unit 2 pcs.

• 20 1396

• 20 1417

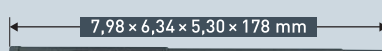

Packnorm 2 Stk. - Packaging unit 2 pcs.

• 20 1411

ADAPTER + PASSENDE AUSWERFERSTIFTE
ADAPTER + SUITABLE EJECTOR PINS

• 20 1263



Packnorm 2 Stk. - Packaging unit 2 pcs.

• 20 1271

• 20 1311



Packnorm 2 Stk. - Packaging unit 2 pcs.

• 20 1271

• 21 0048

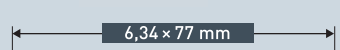

Packnorm 2 Stk. - Packaging unit 2 pcs.

• 20 1261

Ersatz-Innensechskantschrauben für alle Verlängerungen siehe Seite 550
 Spare allen screws for all extensions see page 550

Weiteres Zubehör siehe Übersichtsseite 509
 Further accessories see overview page 509

Spezialverlängerungen + passender Auswerferstift von 30 mm auf 55 mm.
 Somit kann in vielen Fällen auf die längeren Kernbohrer RAIL-LINE 55 verzichtet werden.

Special extension + suitable ejector pin from 30 mm auf 55 mm. This allows
 to renounce the longer annular cutter RAIL-LINE 55.

Ersatz-Innensechskantschrauben für alle Adapter siehe Seite 550
 Spare allen screws for all adapters see page 550



20 1309

RAIL-LINE 755

Hartmetall-bestückter Kernbohrer, Weldonschaft, Nutzlänge 55 mm
Carbide-tipped annular cutter, Weldon shank, drill depth 55 mm | 2"



ANWENDUNG • APPLICATION

Für alle Schienentypen bis 1100 N (UIC 60).
For all rail types up to 1100 N (UIC 60).

Schienen
Rails

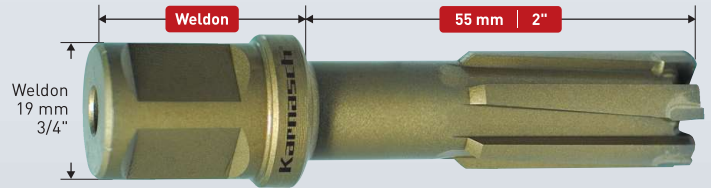

Art.	Ø mm	Ø Zoll Inch
20 1309 018	• 18	45/64"
20 1309 019	• 19	3/4"
20 1309 020	• 20	25/32"
20 1309 021	• 21	53/64"
20 1309 022	• 22	55/64"
20 1309 023	• 23	29/32"

Art.	Ø mm	Ø Zoll Inch
20 1309 024	• 24	15/16"
20 1309 025	• 25	63/64"
20 1309 026	• 26	1.1/32"
20 1309 027	• 27	1.1/16"
20 1309 028	• 28	1.7/64"
20 1309 029	• 29	1.9/64"

Art.	Ø mm	Ø Zoll Inch
20 1309 030	• 30	1.3/16"
20 1309 031	• 31	1.7/32"
20 1309 032	• 32	1.17/64"
20 1309 033	• 33	1.19/64"
20 1309 034	• 34	1.11/32"
20 1309 035	• 35	1.3/8"

Art.	Ø mm	Ø Zoll Inch
20 1309 036	• 36	1.27/64"

⚠ Sonderpreis / Sale Artikel.
Lieferbar solange Vorrat.
Special price / sale article.
While stocks last.

Weitere Ø siehe Art. 20 1690 Seite 524 · **Achtung:** Die Zollabmessungen entsprechen nicht exakt den mm Durchmesser.
Further Ø see Art. 20 1690 page 524 · **Attention:** The inch sizes do not correspond exactly to the mm diameters.

20 1309

RAIL-LINE 755

ZUBEHÖR • ACCESSORIES



AUSWERFERSTIFTE • EJECTOR PINS



Art. 20 1271

Packnorm 2 Stk. · Packaging unit 2 pcs.

EIGENSCHAFTEN • PROPERTIES



Karnasch Hartmetall-bestückte Kernbohrer (HARD-LINE) werden mit konischer Spirale gefertigt für: Sauberen Spanfluss und höchste Zerspanleistung auch bei schwierigen Materialien.

Karnasch carbide tipped annular cutters (HARD-LINE) are made with a conical helix for: clean chip flow and highest cutting ability even with difficult materials.



Karnasch Hartmetall-bestückte Kernbohrer (HARD-LINE) werden ausschließlich mit Sandvik Hartmetallzähnen bestückt. Wir meinen: Nur das beste Hartmetall ist gut genug für Karnasch Kernbohrer.

Karnasch carbide tipped annular cutters (HARD-LINE) are exclusively equipped with Sandvik carbide teeth. Our opinion is: Only the best carbide is good enough for Karnasch annular cutters.



Karnasch Hartmetall-bestückte Kernbohrer (HARD-LINE) sind in einer aufwendigen Vor-Mittel-Nachschneider-Geometrie gefertigt. Dies ergibt: ratterfreies, ruhiges und leichtes Zerspanen mit höchsten Standzeiten. **Die Schnittwinkel sind zum Bohren von Schienen optimiert.**

Karnasch carbide tipped annular cutters (HARD-LINE) are made in an elaborate pre-/intermediate-/after-cutting geometry This results in: clatter-free, silent and easy cutting with highest lifetimes. **The cutting angles are optimized for drilling in rails.**

Schnittdaten
Cutting data

Film
Movie



1487



Zubehör für Hartmetall-bestückte Kernbohrer, Weldonschaft, Nutzlänge 55 mm
 Accessories for carbide-tipped annular cutter, Weldon shank, drill depth 55 mm | 2"

RAIL-LINE 755 20 1309

SETS / DISPLAYS

• 20 1344 • 20 1138 • 20 1132 • 20 1139



max. 44 Stück / Pieces

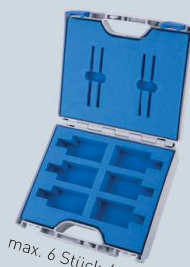

max. 6 Stück / Pieces

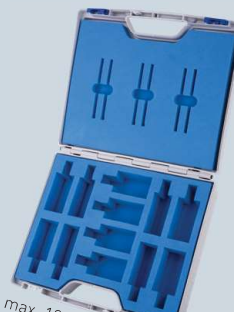

max. 12 Stück / Pieces



max. 50 Stück / Pieces

Sie möchten Ihren Inhalt selbst aussuchen? Kein Problem. Kontaktieren Sie uns und wir stellen Ihr Wunsch-Set oder Wunsch-Display zusammen.

Would you like to select your own contents? No Problem. Contact us and we create your individual set or display.

ADAPTER + PASSENDE AUSWERFERSTIFTE
 ADAPTER + SUITABLE EJECTOR PINS



• 20 1263



• 20 1160

Packnorm 2 Stk. · Packaging unit 2 pcs.



• 20 1311



• 20 1160

Packnorm 2 Stk. · Packaging unit 2 pcs.



• 21 0048



• 20 1271

Packnorm 2 Stk. · Packaging unit 2 pcs.

Ersatz-Innensechskantschrauben für alle Adapter siehe Seite 550
 Spare allen screws for all adapters see page 550

VERLÄNGERUNGEN + PASSENDE AUSWERFERSTIFTE
 EXTENSIONS + SUITABLE EJECTOR PINS



• 20 1387

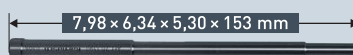

• 20 1396

Packnorm 2 Stk. · Packaging unit 2 pcs.



• 20 1402



• 20 1411

Packnorm 2 Stk. · Packaging unit 2 pcs.



• 20 1417

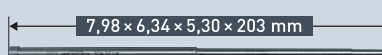

• 20 1426

Packnorm 2 Stk. · Packaging unit 2 pcs.

Ersatz-Innensechskantschrauben für alle Verlängerungen siehe Seite 550
 Spare allen screws for all extensions see page 550

Weiteres Zubehör siehe Übersichtsseite 509
 Further accessories see overview page 509



20 1284

BLUE-DRILL LINE 30 RAIL PRO

Pulverstahl + DURABLU-beschichteter Kernbohrer, Weldonschaft, Nutzlänge 30 mm
Powder steel + DURABLU-coated annular cutter, Weldon shank, drill depth 30 mm | 1"



ANWENDUNG • APPLICATION



Für alle Schienentypen bis 1100 N (UIC 60).

Schienen

For all rail types up to 1100 N (UIC 60).

Rails

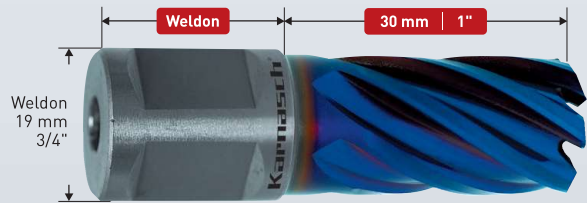

Art.	Ø mm	Ø Zoll Inch	Art.	Ø mm	Ø Zoll Inch	Art.	Ø mm	Ø Zoll Inch	Art.	Ø mm	Ø Zoll Inch
20 1284 012	• 12	15/32"	20 1284 020	• 20	25/32"	20 1284 028	• 28	1.7/64"	20 1284 036	• 36	1.27/64"
20 1284 013	• 13	33/64"	20 1284 021	• 21	53/64"	20 1284 029	• 29	1.9/64"			
20 1284 014	• 14	35/64"	20 1284 022	• 22	55/64"	20 1284 030	• 30	1.3/16"			
20 1284 015	• 15	19/32"	20 1284 023	• 23	29/32"	20 1284 031	• 31	1.7/32"			
20 1284 016	• 16	5/8"	20 1284 024	• 24	15/16"	20 1284 032	• 32	1.17/64"			
20 1284 017	• 17	43/64"	20 1284 025	• 25	63/64"	20 1284 033	• 33	1.19/64"			
20 1284 018	• 18	45/64"	20 1284 026	• 26	1.1/32"	20 1284 034	• 34	1.11/32"			
20 1284 019	• 19	3/4"	20 1284 027	• 27	1.1/16"	20 1284 035	• 35	1.3/8"			

Achtung: Die Zollabmessungen entsprechen nicht exakt den mm Durchmesser.

Attention: The inch sizes do not correspond exactly to the mm diameters.

20 1284

BLUE-DRILL LINE 30 RAIL PRO

ZUBEHÖR • ACCESSORIES



AUSWERFERSTIFTE • EJECTOR PINS



20 1261

Packnorm 2 Stk. • Packaging unit 2 pcs.

EIGENSCHAFTEN • PROPERTIES



Gefertigt aus ASP Pulverstahl zum Bohren auch schwierigster Materialien wie Eisenbahnschienen, Edelstähle, exotische Legierungen. Immer dort einsetzbar wo höchste Verschleißfestigkeit und Standzeit benötigt wird.

Made of ASP powder steel for drilling of difficult materials like railway tracks, stainless steels, exotic alloys. Applicable wherever a high wear resistance and lifetime are required.



Nur wenige Hersteller sind in der Lage in Stufen gehärtete Kernbohrer zu fertigen. Für uns ist dies „Standard“. Dadurch erreichen wir extrem harte Zahnschneiden (68 HRC) und dennoch einen flexiblen Kernbohrer.

Only few manufacturers are capable of producing step-hardened annular cutters. For Karnasch this is "standard". Only this makes us produce extremely hard tooth tips (68 HRC) and yet a flexible annular cutter.

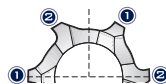

Sieben verschiedene Schneidgeometrien je nach Durchmesser und Schnitttiefe des Kernbohrers optimiert ergeben höchste Zerspanleistung.

Seven different cutting geometries optimally adapted to the different diameter and drill depths leads to high performance cutting results.

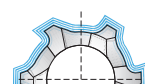

Unsere hochwertigsten Kernbohrer erhalten die einzigartige und patentierte DURABLU-Beschichtung. Extreme Oberflächenhärte- und -glätte ergeben extreme Standzeiten auch unter nicht optimalen Arbeitsbedingungen wie „Über Kopf arbeiten“, Trockenbohrungen, u.s.w.

Our first-class annular cutters are equipped with the unique and patented DURABLU-coating. Extreme surface hardness and sleekness yield extreme lifetimes even under non-optimum circumstances like "overhead work", dry drilling, etc.

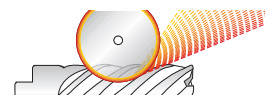

Aus dem vollen Material komplett geschliffen. Dieser Feinschliff erhöht die Zerspanleistung bei gleichzeitiger Reduzierung der Reibung. Für ein Mehr an Standzeit.

Completely made "FULLY GROUND". This refining increases the cutting ability while reducing friction at the same time. For an extended lifetime.

Schnittdaten
Cutting data

Film
Movie



1488



- 1
- 2
- 3
- 4
- 5
- 6
- 7
- 8
- 9
- 10

Index

Zubehör für Pulverstahl + DURABLU-beschichteten Kernbohrer, Weldonschaft, Nutzlänge 30 mm
 Accessories for Powder steel + DURABLU-coated annular cutter, Weldon shank, drill depth 30 mm | 1"

BLUE-DRILL LINE 30
 RAIL PRO **20 1284**

BLUE-DRILL LINE 30
 RAIL PRO

SETS / DISPLAYS Seite / Page 558

Wir bieten eine große Auswahl an Sets / Displays – Inhaltsvorschläge 20 1284 BLUE-DRILL LINE 30 RAIL PRO – siehe Seite 558. Anderer Inhalt auf Wunsch möglich, durch individuell bestückbare Sets / Displays.

We offer a large selection of sets / displays – recommended content 20 1284 BLUE-DRILL LINE 30 RAIL PRO – see page 558. Other content possible by individually equipped sets / displays.



20 1432

Weldon 19 mm 3/4" Weldon+Nitto/Universal 19 mm 3/4"

35 mm

30 mm

6,34 × 102 mm

20 1271

Packnorm 2 Stk. · Packaging unit 2 pcs.

ADAPTER + PASSENDE AUSWERFERSTIFTE
ADAPTER + SUITABLE EJECTOR PINS

20 1263

FEIN Quick-In 18 mm Weldon+Nitto/Universal 19 mm 3/4"

6,34 × 102 mm

20 1271

Packnorm 2 Stk. · Packaging unit 2 pcs.

20 1311

Nitto/Universal 19 mm 3/4" Weldon 19 mm 3/4"

6,34 × 102 mm

20 1271

Packnorm 2 Stk. · Packaging unit 2 pcs.

21 0048

Weldon 32 mm 1.1/4" Weldon + Nitto/Universal 19 mm 3/4"

6,34 × 77 mm

20 1261

Packnorm 2 Stk. · Packaging unit 2 pcs.

Ersatz-Innensechskantschrauben für alle Adapter siehe Seite 550
 Spare allen screws for all adapters see page 550

VERLÄNGERUNGEN + PASSENDE AUSWERFERSTIFTE
EXTENSIONS + SUITABLE EJECTOR PINS

20 1387

Weldon 19 mm 3/4" Weldon+Nitto/Universal 19 mm 3/4"

35 mm

50 mm

7,98 × 6,34 × 5,30 × 127 mm

20 1433

Packnorm 2 Stk. · Packaging unit 2 pcs.

20 1402

Weldon 19 mm 3/4" Weldon+Nitto/Universal 19 mm 3/4"

35 mm

75 mm

7,98 × 6,34 × 5,30 × 153 mm

20 1396

Packnorm 2 Stk. · Packaging unit 2 pcs.

20 1417

Weldon 19 mm 3/4" Weldon+Nitto/Universal 19 mm 3/4"

35 mm

100 mm

7,98 × 6,34 × 5,30 × 178 mm

20 1411

Packnorm 2 Stk. · Packaging unit 2 pcs.

Ersatz-Innensechskantschrauben für alle Verlängerungen siehe Seite 550
 Spare allen screws for all extensions see page 550

Weiteres Zubehör siehe Übersichtsseite 509
 Further accessories see overview page 509

Spezialverlängerungen + passender Auswerferstift von 30 mm auf 50 mm.
 Somit kann in vielen Fällen auf die längeren Kernbohrer RAIL-LINE 50 verzichtet werden.

Special extension + suitable ejector pin from 30 mm to 50 mm. This allows to renounce the longer annular cutter RAIL-LINE 50.

- 1
- 2
- 3
- 4
- 5
- 6
- 7
- 8
- 9
- 10

20 1317

BLUE-DRILL LINE 55 RAIL PRO

Pulverstahl + DURABLU- beschichteter Kernbohrer, Weldonschaft, Nutzlänge 55 mm
Powder steel + DURABLU-coated annular cutter, Weldon shank, drill depth 55 mm | 2"



ANWENDUNG • APPLICATION



Für alle Schienentypen bis 1100 N (UIC 60).

Schienen

For all rail types up to 1100 N (UIC 60).

Rails

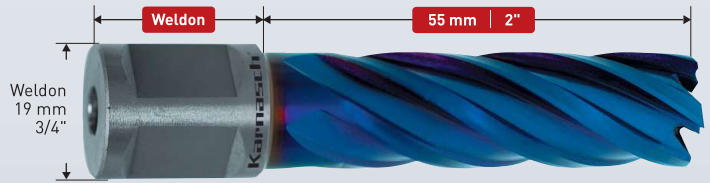

Art.	Ø mm	Ø Zoll Inch
20 1317 012	• 12	15/32"
20 1317 013	• 13	33/64"
20 1317 014	• 14	35/64"
20 1317 015	• 15	19/32"
20 1317 016	• 16	5/8"
20 1317 017	• 17	43/64"
20 1317 018	• 18	45/64"

Art.	Ø mm	Ø Zoll Inch
20 1317 019	• 19	3/4"
20 1317 020	• 20	25/32"
20 1317 021	• 21	53/64"
20 1317 022	• 22	55/64"
20 1317 023	• 23	29/32"
20 1317 024	• 24	15/16"
20 1317 025	• 25	63/64"

Art.	Ø mm	Ø Zoll Inch
20 1317 026	• 26	1.1/32"
20 1317 027	• 27	1.1/16"
20 1317 029	• 29	1.9/64"
20 1317 030	• 30	1.3/16"
20 1317 031	• 31	1.7/32"
20 1317 032	• 32	1.17/64"
20 1317 033	• 33	1.19/64"

Art.	Ø mm	Ø Zoll Inch
20 1317 034	• 34	1.11/32"
20 1317 035	• 35	1.3/8"
20 1317 036	• 36	1.27/64"

% Sonderpreis / Sale Artikel.
Lieferbar solange Vorrat.
Special price / sale article.
While stocks last.

Ersatzartikel siehe Art. 20 1284 Seite 530 + Adapter 20 1432, Art. 20 1309 Seite 528.
Achtung: Die Zollabmessungen entsprechen nicht exakt den mm Durchmesser.
Replacement article see Art. 20 1284 page 530 + adapter 20 1432, Art. 20 1309 page 528.
Attention: The inch sizes do not correspond exactly to the mm diameters.

20 1317

BLUE-DRILL LINE 55 RAIL PRO

ZUBEHÖR • ACCESSORIES



AUSWERFERSTIFTE • EJECTOR PINS



• 20 1271

Packnorm 2 Stk. • Packaging unit 2 pcs.

EIGENSCHAFTEN • PROPERTIES

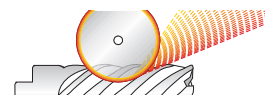
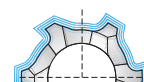
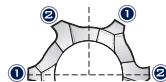

Gefertigt aus ASP Pulverstahl zum Bohren auch schwierigster Materialien wie Eisenbahnschienen, Edelstähle, exotische Legierungen. Immer dort einsetzbar wo höchste Verschleißfestigkeit und Standzeit benötigt wird.

Made of ASP powder steel for drilling of difficult materials like railway tracks, stainless steels, exotic alloys. Applicable wherever a high wear resistance and lifetime are required.

Nur wenige Hersteller sind in der Lage in Stufen gehärtete Kernbohrer zu fertigen. Für uns ist dies „Standard“. Dadurch erreichen wir extrem harte Zahnschneiden (68 HRC) und dennoch einen flexiblen Kernbohrer.

Only few manufacturers are capable of producing step-hardened annular cutters. For Karnasch this is "standard". Only this makes us produce extremely hard tooth tips (68 HRC) and yet a flexible annular cutter.

Sieben verschiedene Schneidgeometrien je nach Durchmesser und Schnitttiefe des Kernbohrers optimiert ergeben höchste Zerspanleistung.

Seven different cutting geometries optimally adapted to the different diameter and drill depths leads to high performance cutting results.

Unsere hochwertigsten Kernbohrer erhalten die einzigartige und patentierte DURABLU-Beschichtung. Extreme Oberflächenhärte- und -glätte ergeben extreme Standzeiten auch unter nicht optimalen Arbeitsbedingungen wie „Über Kopf arbeiten“, Trockenbohrungen, u.s.w.

Our first-class annular cutters are equipped with the unique and patented DURABLU-coating. Extreme surface hardness and sleekness yield extreme lifetimes even under non-optimum circumstances like "overhead work", dry drilling, etc.

Aus dem vollen Material komplett geschliffen. Dieser Feinschliff erhöht die Zerspanleistung bei gleichzeitiger Reduzierung der Reibung. Für ein Mehr an Standzeit.

Completely made "FULLY GROUND". This refining increases the cutting ability while reducing friction at the same time. For an extended lifetime.

Schnittdaten
Cutting data

Film
Movie



1488



- 1
- 2
- 3
- 4
- 5
- 6
- 7
- 8
- 9
- 10

Zubehör für Pulverstahl + DURABLU- beschichteten Kernbohrer, Weldonschaft, Nutzlänge 55 mm
 Accessories for Powder steel + DURABLU-coated annular cutter, Weldon shank, drill depth 55 mm | 2"

BLUE-DRILL LINE 55
RAIL PRO

20 1317

BLUE-DRILL LINE 55
RAIL PRO

SETS / DISPLAYS Seite / Page 559

Wir bieten eine große Auswahl an Sets / Displays – Inhaltsvorschläge 20 1317 BLUE-DRILL LINE 55 RAIL PRO – siehe Seite 559. Anderer Inhalt auf Wunsch möglich, durch individuell bestückbare Sets / Displays.

We offer a large selection of sets / displays – recommended content 20 1317 BLUE-DRILL LINE 55 RAIL PRO – see page 559. Other content possible by individually equipped sets / displays.



ADAPTER + PASSENDE AUSWERFERSTIFTE
ADAPTER + SUITABLE EJECTOR PINS

FEIN Quick-In 18 mm | **Weldon+Nitto/Universal 19 mm 3/4"** | **20 1263**

6,34 × 130 mm | **20 1160**

Packnorm 2 Stk. · Packaging unit 2 pcs.

Nitto/Universal 19 mm 3/4" | **Weldon 19 mm 3/4"** | **20 1311**

6,34 × 130 mm | **20 1160**

Packnorm 2 Stk. · Packaging unit 2 pcs.

Weldon 32 mm 1.1/4" | **Weldon + Nitto/Universal 19 mm 3/4"** | **21 0048**

6,34 × 102 mm | **20 1271**

Packnorm 2 Stk. · Packaging unit 2 pcs.

Ersatz-Innensechskantschrauben für alle Adapter siehe Seite 550
 Spare allen screws for all adapters see page 550

VERLÄNGERUNGEN + PASSENDE AUSWERFERSTIFTE
EXTENSIONS + SUITABLE EJECTOR PINS

35 mm Weldon 19 mm 3/4" | **Weldon+Nitto/Universal 19 mm 3/4"** | **20 1387**

50 mm | **7,98 × 6,34 × 5,30 × 153 mm** | **20 1396**

Packnorm 2 Stk. · Packaging unit 2 pcs.

35 mm Weldon 19 mm 3/4" | **Weldon+Nitto/Universal 19 mm 3/4"** | **20 1402**

75 mm | **7,98 × 6,34 × 5,30 × 178 mm** | **20 1411**

Packnorm 2 Stk. · Packaging unit 2 pcs.

35 mm Weldon 19 mm 3/4" | **Weldon+Nitto/Universal 19 mm 3/4"** | **20 1417**

100 mm | **7,98 × 6,34 × 5,30 × 203 mm** | **20 1426**

Packnorm 2 Stk. · Packaging unit 2 pcs.

Ersatz-Innensechskantschrauben für alle Verlängerungen siehe Seite 550
 Spare allen screws for all extensions see page 550

Weiteres Zubehör siehe Übersichtsseite 509
 Further accessories see overview page 509

- 1
- 2
- 3
- 4
- 5
- 6
- 7
- 8
- 9
- 10

20 1460

SILVER-DRILL LINE RAIL 30

HSS-XE Kernbohrer, Weldonschaft, Nutzlänge 30 mm
HSS-XE annular cutter, Weldon shank, drill depth 30 mm | 1"



ANWENDUNG • APPLICATION

Für alle Schienentypen bis 1100 N (UIC 60).
For all rail types up to 1100 N (UIC 60).

Schienen
Rails

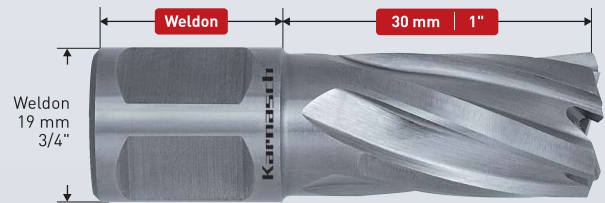

% Sonderpreis / Sale Artikel. Lieferbar solange Vorrat.
Special price / sale article. While stocks last.

Art.	Ø mm	Ø Zoll Inch	Art.	Ø mm	Ø Zoll Inch	Art.	Ø mm	Ø Zoll Inch	Art.	Ø mm	Ø Zoll Inch
20 1460 016	% 16	5/8"	20 1460 023	% 23	29/32"	20 1460 030	% 30	1.3/16"	20 1460 036	% 36	1.27/64"
20 1460 017	% 17	43/64"	20 1460 024	% 24	15/16"	20 1460 031	% 31	1.7/32"			
20 1460 018	% 18	45/64"	20 1460 026	% 26	1.1/32"	20 1460 032	% 32	1.17/64"			
20 1460 020	% 20	25/32"	20 1460 027	% 27	1.1/16"	20 1460 033	% 33	1.19/64"			
20 1460 021	% 21	53/64"	20 1460 028	% 28	1.7/64"	20 1460 034	% 34	1.11/32"			
20 1460 022	% 22	55/64"	20 1460 029	% 29	1.9/64"	20 1460 035	% 35	1.3/8"			

Alternativartikel: Ø 13,5 mm siehe Art. 20 1430 S. 538 + Adapter, Art. 20 1284 S. 530, Art. 20 1306 S. 526 ·
Achtung: Die Zollabmessungen entsprechen nicht exakt den mm Durchmessern.

Alternative article Ø 13,5 mm see Art. 20 1430 p. 538 + adapter, Art. 20 1284 p. 530, Art. 20 1306 p. 526 ·
Attention: The inch sizes do not correspond exactly to the mm diameters.

20 1460

SILVER-DRILL LINE RAIL 30

ZUBEHÖR • ACCESSORIES



AUSWERFERSTIFTE • EJECTOR PINS

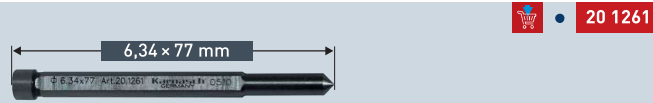

Packnorm 2 Stk. · Packaging unit 2 pcs.

EIGENSCHAFTEN • PROPERTIES

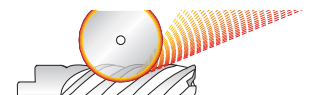
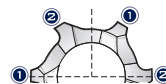

Gefertigt aus hochlegiertem HSS-XE Spezialstahl. Für extreme Härte an den Zahnsitzen (bis 68 HRC). Somit hohe Verschleißfestigkeit und Standzeit.

Made of high-alloyed HSS-XE special steel. For extreme hardness at the tip of the tooth (up to 68 HRC). Thus guaranteeing a high wear resistance and lifetime.

Nur wenige Hersteller sind in der Lage in Stufen gehärtete Kernbohrer zu fertigen. Für uns ist dies „Standard“. Dadurch erreichen wir extrem harte Zahnsitzen (68 HRC) und dennoch einen flexiblen Kernbohrer.

Only few manufacturers are capable of producing step-hardened annular cutters. For Karnasch this is "standard". Only this makes us produce extremely hard tooth tips (68 HRC) and yet a flexible annular cutter.

Sieben verschiedene Schneidgeometrien je nach Durchmesser und Schnitttiefe des Kernbohrers optimiert ergeben höchste Zerspanleistung.

Seven different cutting geometries optimally adapted to the different diameter and drill depths leads to high performance cutting results.

Aus dem vollen Material komplett geschliffen. Dieser Feinschliff erhöht die Zerspanleistung bei gleichzeitiger Reduzierung der Reibung. Für ein Mehr an Standzeit.

Completely made "FULLY GROUND". This refining increases the cutting ability while reducing friction at the same time. For an extended lifetime.

Schnittdaten
Cutting data

Film
Movie



1488



- 1
- 2
- 3
- 4
- 5
- 6
- 7
- 8
- 9
- 10

Zubehör für HSS-XE Kernbohrer, Weldonschaft, Nutzlänge 30 mm
 Accessories for HSS-XE annular cutter, Weldon shank, drill depth 30 mm | 1"

SILVER-DRILL LINE RAIL **30** 20 1460

SETS / DISPLAYS

• 20 1344



max. 44 Stück / Pieces

• 20 1138

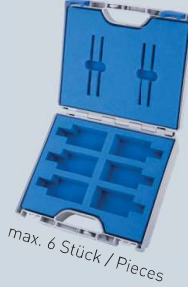

max. 6 Stück / Pieces

• 20 1132

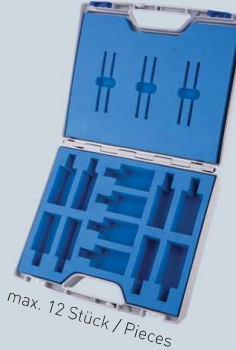

max. 12 Stück / Pieces

• 20 1139



max. 50 Stück / Pieces

Sie möchten Ihren Inhalt selbst aussuchen? Kein Problem. Kontaktieren Sie uns und wir stellen Ihr Wunsch-Set oder Wunsch-Display zusammen.

Would you like to select your own contents? No Problem. Contact us and we create your individual set or display.

• 20 1432

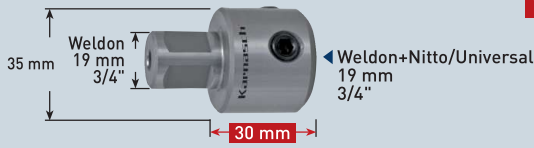

Packnorm 2 Stk. - Packaging unit 2 pcs.

• 20 1271

VERLÄNGERUNGEN + PASSENDE AUSWERFERSTIFTE
 EXTENSIONS + SUITABLE EJECTOR PINS

• 20 1387



Packnorm 2 Stk. - Packaging unit 2 pcs.

• 20 1433

• 20 1402

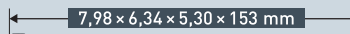

Packnorm 2 Stk. - Packaging unit 2 pcs.

• 20 1396

• 20 1417

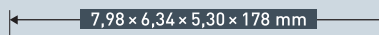

Packnorm 2 Stk. - Packaging unit 2 pcs.

• 20 1411

ADAPTER + PASSENDE AUSWERFERSTIFTE
 ADAPTER + SUITABLE EJECTOR PINS

• 20 1263



Packnorm 2 Stk. - Packaging unit 2 pcs.

• 20 1271

• 20 1311



Packnorm 2 Stk. - Packaging unit 2 pcs.

• 20 1271

• 21 0048

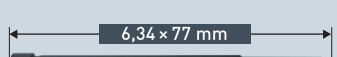

Packnorm 2 Stk. - Packaging unit 2 pcs.

• 20 1261

Ersatz-Innensechskantschrauben für alle Verlängerungen siehe Seite 550
 Spare allen screws for all extensions see page 550

Weiteres Zubehör siehe Übersichtsseite 509
 Further accessories see overview page 509

Ersatz-Innensechskantschrauben für alle Adapter siehe Seite 550
 Spare allen screws for all adapters see page 550



20 1480

SILVER-DRILL LINE RAIL 55

HSS-XE Kernbohrer, Weldonschaft, Nutzlänge 55 mm
HSS-XE annular cutter, Weldon shank, drill depth 55 mm | 2"



ANWENDUNG • APPLICATION



Für alle Schienentypen bis 1100 N (UIC 60).



For all rail types up to 1100 N (UIC 60).



% Sonderpreis / Sale Artikel. Lieferbar solange Vorrat.
Special price / sale article. While stocks last.

Art.	Ø mm	Ø Zoll Inch	Art.	Ø mm	Ø Zoll Inch	Art.	Ø mm	Ø Zoll Inch	Art.	Ø mm	Ø Zoll Inch
20 1480 018	% 18	45/64"	20 1480 023	% 23	29/32"	20 1480 029	% 29	1.9/64"	20 1480 034	% 34	1.11/32"
20 1480 019	% 19	3/4"	20 1480 024	% 24	15/16"	20 1480 030	% 30	1.3/16"	20 1480 035	% 35	1.3/8"
20 1480 020	% 20	25/32"	20 1480 025	% 25	63/64"	20 1480 031	% 31	1.7/32"	20 1480 036	% 36	1.27/64"
20 1480 021	% 21	53/64"	20 1480 027	% 27	1.1/16"	20 1480 032	% 32	1.17/64"			
20 1480 022	% 22	55/64"	20 1480 028	% 28	1.7/64"	20 1480 033	% 33	1.19/64"			

Alternativartikel: Art. 20 1317 Seite 532, Art. 20 1309 Seite 528.
Achtung: Die Zollabmessungen entsprechen nicht exakt den mm Durchmessern.
Alternative article: Art. 20 1317 page 532, Art. 20 1309 page 528.
Attention: The inch sizes do not correspond exactly to the mm diameters.

20 1480

SILVER-DRILL LINE RAIL 55

ZUBEHÖR • ACCESSORIES



AUSWERFERSTIFTE • EJECTOR PINS



20 1271

Packnorm 2 Stk. • Packaging unit 2 pcs.

EIGENSCHAFTEN • PROPERTIES

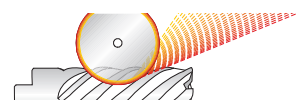
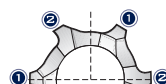

Gefertigt aus hochlegiertem HSS-XE Spezialstahl. Für extreme Härte an den Zahnsitzen (bis 68 HRC). Somit hohe Verschleißfestigkeit und Standzeit.

Made of high-alloyed HSS-XE special steel. For extreme hardness at the tip of the tooth (up to 68 HRC). Thus guaranteeing a high wear resistance and lifetime.

Nur wenige Hersteller sind in der Lage in Stufen gehärtete Kernbohrer zu fertigen. Für uns ist dies „Standard“. Dadurch erreichen wir extrem harte Zahnsitzen (68 HRC) und dennoch einen flexiblen Kernbohrer.

Only few manufacturers are capable of producing step-hardened annular cutters. For Karnasch this is "standard". Only this makes us produce extremely hard tooth tips (68 HRC) and yet a flexible annular cutter.

Sieben verschiedene Schneidgeometrien je nach Durchmesser und Schnitttiefe des Kernbohrers optimiert ergeben höchste Zerspanleistung.

Seven different cutting geometries optimally adapted to the different diameter and drill depths leads to high performance cutting results.

Aus dem vollen Material komplett geschliffen. Dieser Feinschliff erhöht die Zerspanleistung bei gleichzeitiger Reduzierung der Reibung. Für ein Mehr an Standzeit.

Completely made "FULLY GROUND". This refining increases the cutting ability while reducing friction at the same time. For an extended lifetime.

Schnittdaten
Cutting data

Film
Movie



1488



- 1
- 2
- 3
- 4
- 5
- 6
- 7
- 8
- 9
- 10

Index

Zubehör für HSS-XE Kernbohrer, Weldonschaft, Nutzlänge 55 mm
 Accessories for HSS-XE annular cutter, Weldon shank, drill depth 55 mm | 2"

SILVER-DRILL LINE RAIL **55** **20 1480**

SETS / DISPLAYS

• 20 1344 • 20 1138 • 20 1132 • 20 1139



max. 44 Stück / Pieces

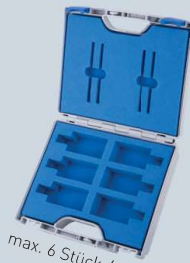

max. 6 Stück / Pieces

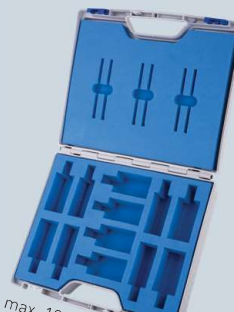

max. 12 Stück / Pieces



max. 50 Stück / Pieces

Sie möchten Ihren Inhalt selbst aussuchen? Kein Problem. Kontaktieren Sie uns und wir stellen Ihr Wunsch-Set oder Wunsch-Display zusammen.

Would you like to select your own contents? No Problem. Contact us and we create your individual set or display.

ADAPTER + PASSENDE AUSWERFERSTIFTE
 ADAPTER + SUITABLE EJECTOR PINS



• 20 1263



• 20 1160

Packnorm 2 Stk. - Packaging unit 2 pcs.



• 20 1311



• 20 1160

Packnorm 2 Stk. - Packaging unit 2 pcs.



• 21 0048



• 20 1271

Packnorm 2 Stk. - Packaging unit 2 pcs.

Ersatz-Innensechskantschrauben für alle Adapter siehe Seite 550
 Spare allen screws for all adapters see page 550

VERLÄNGERUNGEN + PASSENDE AUSWERFERSTIFTE
 EXTENSIONS + SUITABLE EJECTOR PINS



• 20 1387

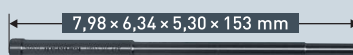

• 20 1396

Packnorm 2 Stk. - Packaging unit 2 pcs.



• 20 1402



• 20 1411

Packnorm 2 Stk. - Packaging unit 2 pcs.



• 20 1417

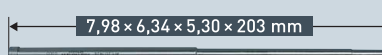

• 20 1426

Packnorm 2 Stk. - Packaging unit 2 pcs.

Ersatz-Innensechskantschrauben für alle Verlängerungen siehe Seite 550
 Spare allen screws for all extensions see page 550

Weiteres Zubehör siehe Übersichtsseite 509
 Further accessories see overview page 509





20 1430

DRILL-LINE 30
RAIL PRO



Pulverstahl + DURABLUE-beschichteter Spiralbohrer, Nutzlänge 30 mm, Weldonschaft oder Fein Quick-In Schaft
Powder steel + DURABLUE-coated twist drill, drill depth 30 mm | 1", Weldon shank or Fein Quick-In shank

ANWENDUNG • APPLICATION

Für alle Schienentypen bis 1100 N (UIC 60).
For all rail types up to 1100 N (UIC 60).

Schienen
Rails



Weldon 19 mm 3/4" Adapter siehe Zubehör
Fein Quick-In 18 mm Adapter see accessories

Art.	Ø mm	Ø Zoll Inch	Art.	Ø mm	Ø Zoll Inch
20 1430 006	6	15/64"	20 1430 013	13	33/64"
20 1430 008	8	5/16"	20 1430 0135	13,5	17/32"
20 1430 0098	9,8	25/64"	20 1430 014	14	35/64"
20 1430 010	10	25/64"	20 1430 015	15	19/32"
20 1430 011	11	7/16"	20 1430 016	16	5/8"
20 1430 012	12	15/32"			

Für Ø 6 - 16 mm benötigen Sie Adapter (siehe Zubehör).
Achtung: Die Zollabmessungen entsprechen nicht exakt den mm Durchmessern.
For Ø 6 - 16 mm you need adapter (see accessories).
Attention: The inch sizes do not correspond exactly to the mm diameters.

ZUBEHÖR • ACCESSORY

Adapter mit Bolzen zum Öffnen der Kühlmittelzufuhr
Adapter with pin for opening the coolant supply

WELDON 19 mm (3/4")

Ø 6-12 mm • 20 1431

Ø 13-16 mm • 20 1434

FEIN QUICK-IN

Ø 6-12 mm • 20 1421

Ø 13-16 mm • 20 1422

20 1430

DRILL-LINE 40
RAIL PRO



Pulverstahl + DURABLUE-beschichteter Spiralbohrer mit Innenkühlung, Nutzlänge 40 mm, Weldonschaft
Powder steel + DURABLUE-coated twist drill with internal cooling supply, drill depth 40 mm | 1.1/2", Weldon shank

ANWENDUNG • APPLICATION

Für alle Schienentypen bis 1100 N (UIC 60).
For all rail types up to 1100 N (UIC 60).

Schienen
Rails

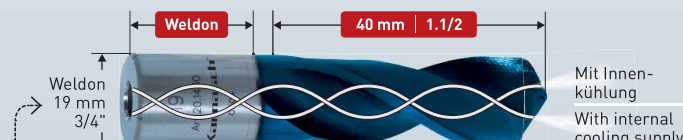

Ø 17-27,5 mm wird ohne Bolzen zum Öffnen der Kühlmittelzufuhr geliefert (wenn benötigt siehe Zubehör).
Ø 17-27,5 mm will be delivered without pin for opening the cooling supply (see accessories if required).

Art.	Ø mm	Ø Zoll Inch	Art.	Ø mm	Ø Zoll Inch
20 1430 017	17	43/64"	20 1430 023	23	29/32"
20 1430 018	18	45/64"	20 1430 024	24	15/16"
20 1430 019	19	3/4"	20 1430 0275	27,5	1.5/64"
20 1430 020	20	25/32"			
20 1430 021	21	53/64"			
20 1430 022	22	55/64"			

Weitere Abmessungen sowie Schnitttiefe 50 mm siehe nächste Seite Art. 20 1465.
Achtung: Die Zollabmessungen entsprechen nicht exakt den mm Durchmessern.
More dimensions and cutting depth 50 mm see next page art. 20 1465.
Attention: The inch sizes do not correspond exactly to the mm diameters.

% Sonderpreis / Sale Artikel. Lieferbar solange Vorrat.
Special price / sale article. While stocks last.

ZUBEHÖR • ACCESSORY

Der Bolzen ist nur notwendig, wenn Aufnahmehalter mit Innenkühlung verwendet werden (Siehe Seite 541-543).
The pin is only necessary if you use tool holders with internal cooling supply (see page 541-543).

Bolzen zum Öffnen der Kühlmittelzufuhr
Pin for opening the cooling supply

• 20 1435

Schnittdaten
Cutting data

Film
Movie

1488

Pulverstahl + DURABLU-beschichteter Spiralbohrer mit Innenkühlung, Nutzlänge 50 mm, Weldonschaft
 Powder steel + DURABLU-coated twist drill with internal cooling supply, drill depth 50 mm | 2", Weldon shank

DRILL-LINE **RAIL** **50** **PRO** **20 1465**

ANWENDUNG · APPLICATION

Für alle Schienentypen bis 1100 N (UIC 60).
For all rail types up to 1100 N (UIC 60).

Schienen
 Rails

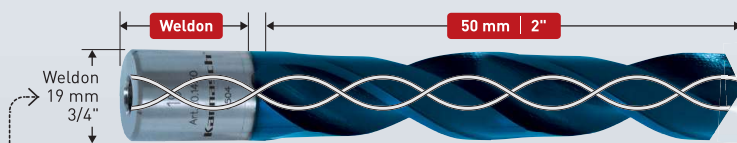

Mit Innenkühlung
 With internal cooling supply

Wird ohne Bolzen zum Öffnen der Kühlmittelzufuhr geliefert (wenn benötigt siehe Zubehör).
 Will be delivered without pin for opening the cooling supply (see accessories if required).

Art.	Ø mm	Ø Zoll Inch	Art.	Ø mm	Ø Zoll Inch	Art.	Ø mm	Ø Zoll Inch
20 1465 014	• 14	35/64"	20 1465 020	• 20	25/32"	20 1465 026	• 26	1.1/32"
20 1465 015	• 15	19/32"	20 1465 021	• 21	53/64"	20 1465 027	• 27	1.1/16"
20 1465 016	• 16	5/8"	20 1465 022	• 22	55/64"	20 1465 028	• % 28	1.7/64"
20 1465 017	• 17	43/64"	20 1465 023	• 23	29/32"	20 1465 030	• 30	1.3/16"
20 1465 018	• 18	45/64"	20 1465 024	• 24	15/16"	20 1465 032	• 32	1.17/64"
20 1465 019	• 19	3/4"	20 1465 025	• 25	63/64"			

Achtung: Die Zollabmessungen entsprechen nicht exakt den mm Durchmesser.

Attention: The inch sizes do not correspond exactly to the mm diameters.

Sonderpreis / Sale Artikel. Lieferbar solange Vorrat.
 Special price / sale article. While stocks last.

ZUBEHÖR · ACCESSORY

Der Bolzen ist nur notwendig, wenn Aufnahmehalter mit Innenkühlung verwendet werden (Siehe Seite 541-543).

The pin is only necessary if you use tool holders with internal cooling supply (see page 541-543).

Bolzen zum Öffnen der Kühlmittelzufuhr
 Pin for opening the cooling supply



• **20 1435**

EIGENSCHAFTEN · PROPERTIES

Für Art. 20 1430 Seite 538 sowie für Art. 20 1465 · For Art. 20 1430 page 538 and for Art. 20 1465



Gefertigt aus ASP Pulverstahl zum Bohren auch schwierigster Materialien wie Eisenbahnschienen, Edelstähle, exotische Legierungen. Immer dort einsetzbar wo höchste Verschleißfestigkeit und Standzeit benötigt wird.

Made of ASP powder steel for drilling of difficult materials like railway tracks, stainless steels, exotic alloys. Applicable wherever a high wear resistance and lifetime are required.

Karnasch Spiralbohrer werden mit einer Hochleistungsgeometrie gefertigt für: Sofortiges Selbstzentrieren, leichteres Zerspanen, höchste Standzeiten.

Karnasch twist drills are produced in a heavy-duty geometry for immediate self-centering, easy cutting, highest lifetimes.

Unsere hochwertigsten Spiralbohrer erhalten die einzigartige und patentierte DURABLU-Beschichtung. Extreme Oberflächenhärte- und -glätte ergeben extreme Standzeiten auch unter nicht optimalen Arbeitsbedingungen wie „Über Kopf arbeiten“, Trockenbohrungen, u.s.w.

Our first-class twist drills are equipped with the unique and patented DURABLU-coating. Extreme surface hardness and sleekness yield extreme lifetimes even under non-optimum conditions like "overhead work", dry drilling, etc.

Schnittdaten
 Cutting data

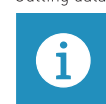

1488

Film
 Movie



539

1
 2
 3
 4
 5
 6
 7
 8
 9
 10



20 1710

DRILL-LINE
RAIL 30



HSS-XE Spiralbohrer, Nutzlänge 30 mm, Weldonschaft
HSS-XE twist drill, drill depth 30 mm | 1", Weldon shank

ANWENDUNG • APPLICATION

Für alle Schienentypen bis 1100 N (UIC 60).
For all rail types up to 1100 N (UIC 60).

Schienen
Rails

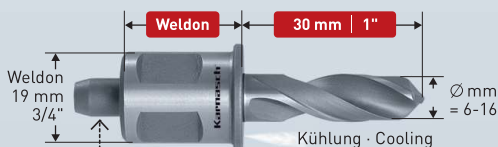

Ø 6-16 mm wird mit Bolzen zum Öffnen der Kühlmittelzufuhr geliefert.
Ø 6-16 mm will be delivered with pin for opening the cooling supply.

Art.	Ø mm	Ø Zoll	Art.	Ø mm	Ø Zoll
20 1710 006	6	15/64"	20 1710 012	12	15/32"
20 1710 008	8	5/16"	20 1710 013	13	33/64"
20 1710 0095	9,5	25/64"	20 1710 0135	13,5	17/32"
20 1710 0098	9,8	25/64"	20 1710 014	14	35/64"
20 1710 010	10	25/64"	20 1710 015	15	19/32"
20 1710 011	11	7/16"	20 1710 016	16	5/8"

Achtung: Die Zollabmessungen entsprechen nicht exakt den mm Durchmessern.
Attention: The inch sizes do not correspond exactly to the mm diameters.

20 1710

DRILL-LINE
RAIL 40



HSS-XE Spiralbohrer mit Innenkühlung, Nutzlänge 40 mm, Weldonschaft
HSS-XE twist drill with internal cooling supply, drill depth 40 mm | 1", Weldon shank

ANWENDUNG • APPLICATION

Für alle Schienentypen bis 1100 N (UIC 60).
For all rail types up to 1100 N (UIC 60).

Schienen
Rails

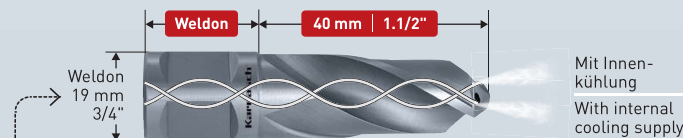

Ø 17-27,5 mm wird ohne Bolzen zum Öffnen der Kühlmittelzufuhr geliefert (wenn benötigt siehe Zubehör).
Ø 17-27,5 mm will be delivered without pin for opening the cooling supply (see accessories if required).

Art.	Ø mm	Ø Zoll	Art.	Ø mm	Ø Zoll
20 1710 017	17	43/64"	20 1710 024	24	15/16"
20 1710 019	19	3/4"	20 1710 0275	27,5	1.5/64"
20 1710 020	20	25/32"			
20 1710 021	21	53/64"			
20 1710 022	22	55/64"			
20 1710 023	23	29/32"			

Ersatzartikel siehe Art. 20 1430 Seite 538 / Replacement article see Art. 20 1430 page 538

Achtung: Die Zollabmessungen entsprechen nicht exakt den mm Durchmessern.
Attention: The inch sizes do not correspond exactly to the mm diameters.

ZUBEHÖR • ACCESSORY

Der Bolzen ist nur notwendig, wenn Aufnahmehalter mit Innenkühlung verwendet werden (Siehe Seite 541-543).
The pin is only necessary if you use tool holders with internal cooling supply (see page 541-543).

Bolzen zum Öffnen der Kühlmittelzufuhr
Pin for opening the cooling supply



20 1435

EIGENSCHAFTEN • PROPERTIES



Gefertigt aus hochlegiertem HSS-XE Spezialstahl. Für extreme Härte an den Zahnsitzen (bis 68 HRC). Somit hohe Verschleißfestigkeit und Standzeit.

Karnasch Spiralbohrer werden mit einer Hochleistungsgeometrie gefertigt für: Sofortiges Selbstzentrieren, leichteres Zerspanen, höchste Standzeiten.

Made of high-alloyed HSS-XE special steel. For extreme hardness at the tip of the tooth (up to 68 HRC). Thus guaranteeing a high wear resistance and lifetime.

Karnasch twist drills are produced in a heavy-duty geometry for immediate self-centering, easy cutting, highest lifetimes.

Schnittdaten
Cutting data

Film
Movie



1488



Sekundenschneller Kernbohrwechsel ohne Werkzeug. Passend für alle Kernbohrer mit Weldon + Nitto / Universalschaft 19 mm (3/4").

- Für alle HSS-XE-Kernbohrer bis max. Ø 60 mm sowie max. Schnitttiefe 55 mm
- Für alle HM-Kernbohrer bis max. Ø 50 mm sowie max. Schnitttiefe 55 mm

Alle Schnellwechsel Aufnahmen sind komplett verchromt und somit Schmutz- und Rostbeständig. Selbstverständlich kommen alle Aufnahmen, mit Innenkühlung, mit dem bewährten Schnellwechsel-Kühlmittelschlauchsystem.

Verwenden Sie Karnasch **QUICK-CHANGE** -Halter nur mit Original Karnasch Kernbohrern. Die einwandfreie Funktion des Karnasch **QUICK-CHANGE** -Halters mit anderen Fabrikaten können wir nicht garantieren.

Changing annular cutters in a matter of seconds without tools. Suitable for all annular cutters with Weldon shank / Universal + Weldon shank 19 mm (3/4").

- All HSS-XE annular cutters up to a diameter of 60 mm. Cutting depth 55 mm.
- All carbide tipped annular cutters up to a diameter of 50 mm. Cutting depth 55 mm.

All Quick-Change holders are fully chromed and thus dirt and rust resistant. All Quick-Change holders with internal cooling, comes with the proven

Quickchange coolant hose system.

Use Karnasch **QUICK-CHANGE** holders only with original Karnasch annular cutters. We cannot guarantee a faultless operation of the Karnasch **QUICK-CHANGE** holder in combination with other products.

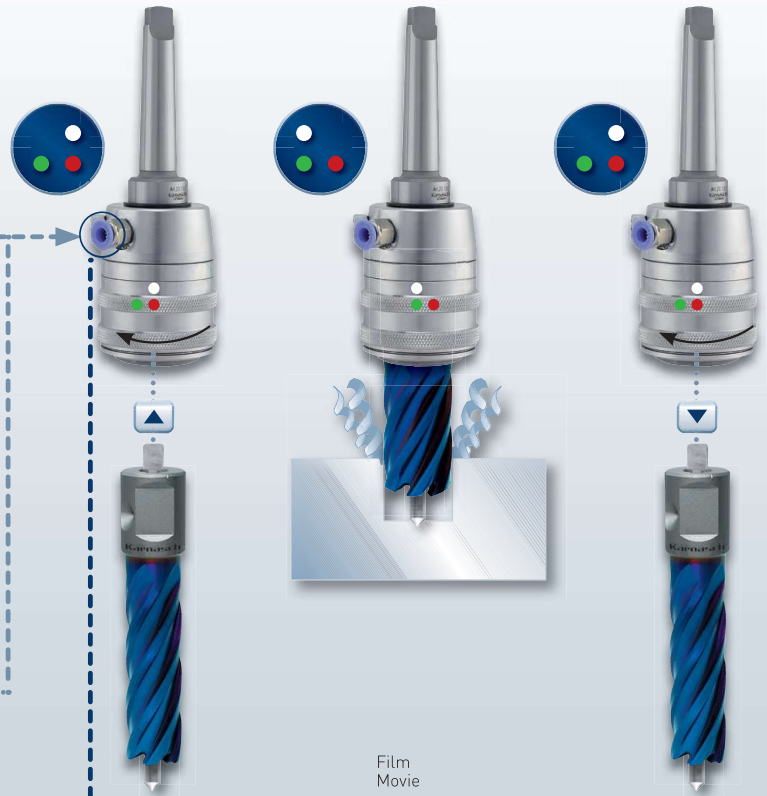

Film Movie



Ersatzteil: Schnellwechsel-Kühlmittelschlauchhalter für alle MK Aufnahmen mit Innenkühlung
Spare part: Quick-change coolant hose holder for all Morse taper holders with internal cooling

Aufnahmehalter Tool holder	QUICK-CHANGE	MIT INNENKÜHLUNG WITH INTERNAL COOLING	für Kernbohrer mit Schaft for annular cutter with shank	: Weldon + Nitto / Universal 19 mm (3/4")
Morsekegel (MK) · Morse taper (MT)	Aufnahmehalter · Tool holder	Art.	Hinweise · Notes	
2		• 20 1303	Bei Schnitttiefen über 55 mm sind 2-teilige Auswerferstifte zu verwenden.	
3		• 20 1307	For drill depths more than 55 mm 2-part ejector pins must be used.	
Aufnahmehalter Tool holder	QUICK-CHANGE	OHNE INNENKÜHLUNG WITHOUT INTERNAL COOLING	für Kernbohrer mit Schaft for annular cutter with shank	: Weldon + Nitto / Universal 19 mm (3/4")
Morsekegel (MK) · Morse taper (MT)	Aufnahmehalter · Tool holder	Art.	Hinweise · Notes	
2		• 20 1301	Bei Schnitttiefen über 55 mm sind 2-teilige Auswerferstifte zu verwenden.	
3		• 20 1437	For drill depths more than 55 mm 2-part ejector pins must be used.	

- 1
- 2
- 3
- 4
- 5
- 6
- 7
- 8
- 9
- 10

- 1 
- 2 
- 3 
- 4 
- 5 
- 6 
- 7 
- 8 
- 9 
- 10 

Aufnahmehalter Tool holder	MIT INNENKÜHLUNG WITH INTERNAL COOLING	für Kernbohrer mit Schaft for annular cutter with shank	: Weldon + Nitto / Universal 19 mm (3/4")	
Morsekegel (MK) - Morse taper (MT)	Aufnahmehalter · Tool holder	Art.	Hinweise · Notes	
2		 • 20 1287	Bei Schnitttiefen über 55 mm sind 2-teilige Auswerferstifte zu verwenden. * Alle Aufnahmen, mit Innenkühlung, kommen mit dem bewährten Schnellwechsel-Kühlmittelschlauchsystem. For drill depths more than 55 mm 2-part ejector pins must be used. * All Quick-Change holders with internal cooling, comes with the proven Quick-change coolant hose system.	
3		 • 20 1289		
4		 • 20 1310		





Aufnahmehalter Tool holder	OHNE INNENKÜHLUNG WITHOUT INTERNAL COOLING	für Kernbohrer mit Schaft for annular cutter with shank	: Weldon + Nitto / Universal 19 mm (3/4")	
Morsekegel (MK) - Morse taper (MT)	Aufnahmehalter · Tool holder	Art.	Hinweise · Notes	
2		 • 20 1283	Bei Schnitttiefen über 55 mm sind 2-teilige Auswerferstifte zu verwenden. For drill depths more than 55 mm 2-part ejector pins must be used.	
3		 • 20 1293		
4		 • 20 1841		

Aufnahmehalter extra lang Tool holder extra long	MIT INNENKÜHLUNG WITH INTERNAL COOLING	für Kernbohrer mit Schaft for annular cutter with shank	: Weldon + Nitto / Universal 19 mm (3/4")	
Morsekegel (MK) - Morse taper (MT)	Aufnahmehalter · Tool holder	Art.	Hinweise · Notes	
2		 • 20 1842	Bei den Aufnahmehaltern entfällt das Umstecken 2-teiliger Auswerferstifte. Es kann mit 1-teiligen Auswerferstiften kontinuierlich bis 110 mm Schnitttiefe gebohrt werden. * Alle Aufnahmen, mit Innenkühlung, kommen mit dem bewährten Schnellwechsel-Kühlmittelschlauchsystem. With these tool holders replugging of the 2-piece ejector pins is not necessary. You can drill as deep as 110 mm in one working process with a 1-part ejector pin. * All Quick-Change holders with internal cooling, comes with the proven Quick-change coolant hose system.	
3		 • 20 1291		
4		 • 20 1843		

 • **21 0047**

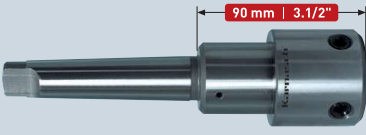
Ersatzteil: Schnellwechsel-Kühlmittelschlauchhalter für alle MK Aufnahmen mit Innenkühlung
Spare part: Quick-change coolant hose holder for all MT holders with internal cooling

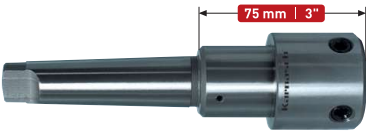
Aufnahmehalter Tool holder	MIT INNENKÜHLUNG WITH INTERNAL COOLING	für Kernbohrer mit Schaft for annular cutter with shank	: Weldon 32 mm (1.1/4")	
Morsekegel (MK) · Morse taper (MT)	Aufnahmehalter · Tool holder	Art.	Hinweise · Notes	
3		 • 20 1290	Bei Schnitttiefen über 55 mm sind 2-teilige Auswerferstifte zu verwenden. Bei Durchmessern über 100 mm empfehlen wir MK 4 oder MK 5 Morsekegel.	
4		 • 20 1292	* Alle Aufnahmen, mit Innenkühlung, kommen mit dem bewährten Schnellwechsel-Kühlmittelschlauchsystem.	
5		 • 20 1395	For drill depths more than 55 mm 2 part ejector pins must be used. For diameters more than 100 mm we recommend MT 4 or MT 5 morse taper. * All Quick-Change holders with internal cooling, comes with the proven Quick-change coolant hose system.	

Aufnahmehalter Tool holder	OHNE INNENKÜHLUNG WITHOUT INTERNAL COOLING	für Kernbohrer mit Schaft for annular cutter with shank	: Weldon 32 mm (1.1/4")	
Morsekegel (MK) · Morse taper (MT)	Aufnahmehalter · Tool holder	Art.	Hinweise · Notes	
3		 • 20 1286	Bei Schnitttiefen über 55 mm sind 2-teilige Auswerferstifte zu verwenden. Bei Durchmessern über 100 mm empfehlen wir MK 4 Morsekegel.	
4		 • 20 1844	For drill depths more than 55 mm 2 part ejector pins must be used. For diameters more than 100 mm we recommend MT 4 morse taper.	

Aufnahmehalter extra lang Tool holder extra long	MIT INNENKÜHLUNG WITH INTERNAL COOLING	für Kernbohrer mit Schaft for annular cutter with shank	: Weldon 32 mm (1.1/4")	
Morsekegel (MK) · Morse taper (MT)	Aufnahmehalter · Tool holder	Art.	Hinweise · Notes	
3		 • 20 1845	Bei diesen Aufnahmehaltern entfällt das Umstecken 2-teiliger Auswerferstifte. Es kann mit 1-teiligen Auswerferstiften kontinuierlich bis 110 mm Schnitttiefe gebohrt werden. Bei Durchmessern über 100 mm empfehlen wir MK 4 Morsekegel.	
4		 • 20 1846	With this tool holders replugging of the 2-pieces ejector pins is not necessary. You can drill as deep as 110 mm in one working process with a 1-part ejector pin. For diameter more than 100 mm we recommend MT 4 morse taper. * All Quick-Change holders with internal cooling, comes with the proven Quick-change coolant hose system.	

Zubehör Aufnahmehalter Accessories Tool holder	Reduzierhülsen Reduction sleeves			
	Beschreibung · Specification	Länge · Length	Art.	
	Reduzierung von MK 3 (außen) auf MK 2 (innen) Reduction from MT 3 (outside) to MT 2 (inside)	112 mm	• 21 0052	
	Reduzierung von MK 4 (außen) auf MK 3 (innen) Reduction from MT 4 (outside) to MT 3 (inside)	140 mm	• 21 0053	

- 1 
- 2 
- 3 
- 4 
- 5 
- 6 
- 7 
- 8 
- 9 
- 10 



- 1
- 2
- 3
- 4
- 5
- 6
- 7
- 8
- 9
- 10



ANWENDUNG · APPLICATION

Stahl	Edelstahl	Grauguss	Alu	Kupfer, Messing, Zinn	Kunststoffe GFK/CFK	Hardox 400	Hardox 450
Steel	Stainless	Grey cast iron	Alu	Copper, brass, tin	Plastics GRP/CRP	Hardox 400	Hardox 450
< 900 N	< 900 N		> 10% Si				

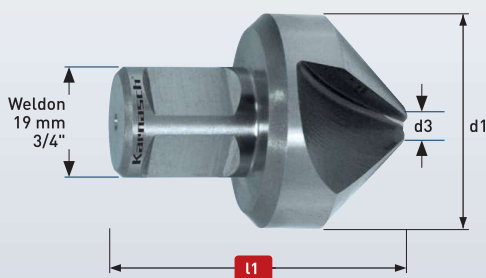

ANWENDUNG · APPLICATION

Stahl	Edelstahl	Grauguss	Alu	Kupfer, Messing, Zinn	Kunststoffe GFK/CFK	Hardox 400	Hardox 450
Steel	Stainless	Grey cast iron	Alu	Copper, brass, tin	Plastics GRP/CRP	Hardox 400	Hardox 450
< 1100 N	< 900 N		> 10% Si				

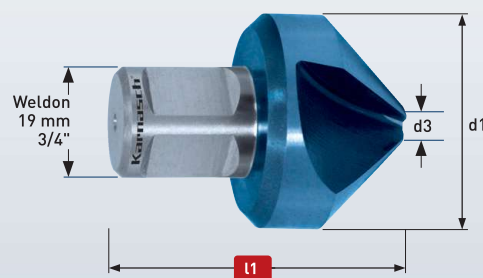

Passende Morsekonusaufnahmen siehe Seite 541-543 · Suitable morse taper see page 541-543



EIGENSCHAFTEN · PROPERTIES

HSS-XE Stahl

20 1295

Gefertigt aus hochlegierten Spezialstahl "XE" für wesentlich höhere Standzeiten gegenüber HSS-Stähle.

Ideal zum Senken in:

- Stahl
- Guss
- Bunt- und Leichtmetalle

HSS-XE Stahl + BLUE-TEC beschichtet

20 1195

Gefertigt aus hochlegierten Spezialstahl "XE" für wesentlich höhere Standzeit gegenüber HSS-Stähle. BLUE-TEC Beschichtung für eine nochmalige wesentliche Erhöhung der Standzeit auch bei Trockenbearbeitung (ohne/wenig Kühlung).

Zum Senken in:

- Edelmstähle (V2A / V4A)
- Stahl
- Guss
- Bunt- und Leichtmetalle

HSS-XE steel

Made of high-alloyed special steel „XE“ for considerably longer service life than HSS-steel.

Excellent for countersinking in:

- Steel
- Cast iron
- Non-ferrous metals

HSS-XE steel + BLUE-TEC coated

Made of high-alloyed special steel „XE“ for considerably longer service life than HSS-steel. BLUE-TEC coating for a further substantial increase in service life also when machining dry (no/little cooling).

Excellent for countersinking in:

- High-alloyed chromium steel such as stainless (V2A / V4A)
- Acid resistant steel
- Steel
- Cast iron
- Non-ferrous metals

d1 Ø mm	d3 Ø mm	Gesamtlänge Total length L1 mm	20 1295
• 25	4	45	20 1295 025
• 30	4	47	20 1295 030
• 40	7	52	20 1295 040
• 55	9	60	20 1295 055



d1 Ø mm	d3 Ø mm	Gesamtlänge Total length L1 mm	20 1195
• 25	4	45	20 1195 025
• 30	4	47	20 1195 030
• 40	7	52	20 1195 040
• 55	9	60	20 1195 055



Schnittdaten
Cutting data

Film
Movie



1513





20 1796 040



ANWENDUNG · APPLICATION

Stahl	Edelstahl	Grauguss	Alu	Kupfer, Messing, Zinn	Kunststoffe GFK/CFK	Hastelloy, Inconel, Exotische Materialien	Hardox 400
Steel	Stainless	Grey cast iron	Alu	Copper, brass, tin	Plastics GRP/CRP	Hastelloy, Inconel, exotic materials	Hardox 400
< 1400 N	< 900 N		> 10% Si				

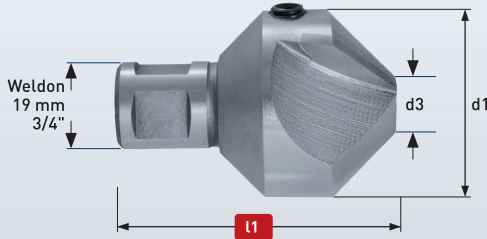

d1 Ø mm	d3 Ø mm	Gesamtlänge Total length L1 mm
40	10	60

Passende Morsekonusaufnahmen
siehe Seite 541-543 ·
Suitable morse taper see page 541-543

EIGENSCHAFTEN · PROPERTIES

Hartmetall-bestückt für höchste Standzeiten
auch bei schwierigsten Materialien.

Ideal zum Senken in:

- Abrasive und harte Stähle über 1000 N/mm²
- Grauguss (GG) über 240 HB
- Rost- und säurebeständige Stähle
- Titan- und Titanlegierungen
- Alle weiteren Stähle, Guss und Leichtmetalle wo höchste Standzeiten erwünscht sind.

Tungsten carbide tipped for maximum tool life,
even in most difficult materials.

For countersinking in:

- Abrasive and hard steel with a strength of over 1000 N/mm²
- Grey cast iron over 240 HB
- High-alloyed chromium steel such as stainless (V2A / V4A)
- Acid resistant steel
- Titanium and titanium alloys
- All further steel sorts, cast iron, non-ferrous metals where maximum tool life are desired.

Die Führungsstifte ergeben hervorragende Stabilität und Genauigkeit.
Sollte ohne Führungsbohrer gearbeitet werden, bitte den Kegelsenker
100% mittig zur Bohrung ausrichten.

The pilots provide great stability and accuracy. If drilling without pilots,
please take care, that the countersink is adjusted absolutely centrally
to the drilled hole.

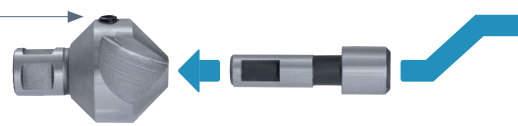

Ersatzteil

Ersatzschraube zum Befestigen
der Führungsstifte

20 1455



Spare part

Spare screw for fixing the pilots

FÜHRUNGSSTIFTE · PILOTS

	20 1797		21 1784
	21 1780		21 1785
	21 1781		20 1799
	21 1782		21 1786
	20 1798		21 1787
	21 1783		21 1788

Schnittdaten
Cutting data



1453





20 1786 045

ANWENDUNG · APPLICATION

Stahl	Edelstahl	Grauguss	Alu	Kupfer, Messing, Zinn	Kunststoffe GFK/CFK	Hastelloy, Inconel, Exotische Materialien	Hardox 400
Steel	Stainless	Grey cast iron	Alu	Copper, brass, tin	Plastics GRP/CRP	Hastelloy, Inconel, exotic materials	Hardox 400
< 1400 N	< 900 N		> 10% Si				

Dieser Kegelsenker wird geliefert mit:

- 4 Stück Hartmetall-Einsätze beschichtet inkl. 4 TORX Befestigungsschrauben sowie 1 TORX Befestigungsschlüssel komplett montiert.
- Die dreieckigen Einsätze sind drehbar. Somit sind alle 3 Schneidflächen einsetzbar für 3-fache Standzeit.
- **Passende Führungsstifte siehe unten.**

These countersinks come inclusive:

- 4 pieces carbide inserts coated incl. 4 TORX mounting screws and 1 TORX wrench. Fully assembled.
- The triangular inserts are rotatable. This means that all 3 cutting surfaces can be used for 3 times more lifetime.
- **Suitable pilots pins see below.**

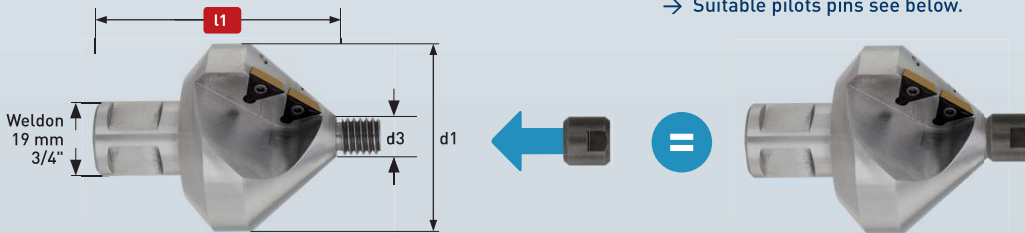

Schnittdaten
Cutting data



d1 Ø mm	d3 Ø mm	Gesamtlänge Total length L1 mm
45	10	72

Passende Morsekonusaufnahmen
siehe Seite 541-543

Suitable morse taper see page 541-543



EIGENSCHAFTEN · PROPERTIES

Hartmetall-bestückt für höchste Standzeiten auch bei schwierigsten Materialien.

Ideal zum Senken in:

- Abrasive und harte Stähle über 1000 N/mm²
- Grauguss (GG) über 240 HB
- Rost- und säurebeständige Stähle
- Titan- und Titanlegierungen
- Alle weiteren Stähle, Guss und Leichtmetalle wo höchste Standzeiten erwünscht sind.

Tungsten carbide tipped for maximum tool life, even in the most difficult materials.

For countersinking in:

- Abrasive and hard steel with a strength of over 1000 N/mm²
- Grey cast iron over 240 HB
- High-alloyed chromium steel such as stainless (V2A / V4A)
- Acid resistant steel
- Titanium and titanium alloys
- All further steel sorts, cast iron, non-ferrous metals where maximum tool life are desired.

Die Führungsstifte ergeben hervorragende Stabilität und Genauigkeit. Sollte ohne Führungsbohrer gearbeitet werden, bitte den Kegelsenker 100% mittig zur Bohrung ausrichten.

The pilots provide great stability and accuracy. If drilling without pilots, please take care, that the countersink is adjusted absolutely centrally to the drilled hole.



FÜHRUNGSSTIFTE · PILOTS

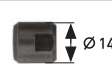

20 1787 010



20 1787 060

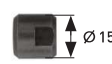

20 1787 020



20 1787 070

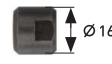

20 1787 030

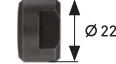

20 1787 075

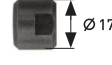

20 1787 040

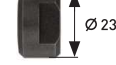

20 1787 080



20 1787 045



20 1787 090

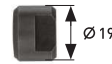

20 1787 050

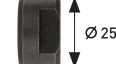

20 1787 100

ERSATZTEILE · SPARE PARTS



Auswechselbare Platten
Packnorm 4 Stück
Carbide inserts
Packing unit 4 pcs.

20 1787 110



4x TORX Befestigungsschrauben
Packnorm 4 Stück
4x TORX mounting screw
Packing unit 4 pcs.

20 1787 120



1x Befestigungsschlüssel
1x TORX wrench

22 9011 0175



20 1776 045



ANWENDUNG · APPLICATION

Stahl	Edelstahl	Grauguss	Alu	Kupfer, Messing, Zinn	Kunststoffe GFK/CFK	Hastelloy, Inconel, Exotische Materialien	Hardox 400
Steel	Stainless	Grey cast iron	Alu	Copper, brass, tin	Plastics GRP/CRP	Hastelloy, Inconel, exotic materials	Hardox 400
< 1400 N	< 900 N		> 10% Si				

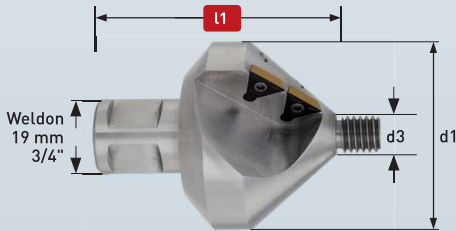

d1	d1	d3	d3	Gesamtlänge L1	
Ø Zoll/Inch	Ø mm	Ø Zoll/Inch	Ø mm	Zoll/Inch	mm
1.49/64"	45	3/8"	10	2.53/64"	72

Dieser Kegelsenker wird geliefert mit:

- 4 Stück Hartmetall-Einsätze beschichtet inkl. 4 TORX Befestigungsschrauben sowie 1 TORX Befestigungsschlüssel komplett montiert.
- Die dreieckigen Einsätze sind drehbar. Somit sind alle 3 Schneidflächen einsetzbar für 3-fache Standzeit.
- **Passende Führungsstifte siehe unten.**

These countersinks come inclusive:

- 4 pieces carbide inserts coated incl. 4 TORX mounting screws and 1 TORX wrench. Fully assembled.
- The triangular inserts are rotatable. This means that all 3 cutting surfaces can be used for 3 times more lifetime.
- **Suitable pilots pins see below.**



Schnittdaten
Cutting data



Passende Morsekonusaufnahmen
siehe Seite 541-543
Suitable morse taper see page 541-543



EIGENSCHAFTEN · PROPERTIES

Hartmetall-bestückt für höchste Standzeiten auch bei schwierigsten Materialien.

Ideal zum Senken in:

- Abrasive und harte Stähle über 1000 N/mm²
- Grauguss (GG) über 240 HB
- Rost- und säurebeständige Stähle
- Titan- und Titanlegierungen
- Alle weiteren Stähle, Guss und Leichtmetalle wo höchste Standzeiten erwünscht sind.

Tungsten carbide tipped for maximum tool life, even in the most difficult materials.

For countersinking in:

- Abrasive and hard steel with a strength of over 1000 N/mm²
- Grey cast iron over 240 HB
- High-alloyed chromium steel such as stainless (V2A / V4A)
- Acid resistant steel
- Titanium and titanium alloys
- All further steel sorts, cast iron, non-ferrous metals where maximum tool life are desired.

Die Führungsstifte ergeben hervorragende Stabilität und Genauigkeit. Sollte ohne Führungsbohrer gearbeitet werden, bitte den Kegelsenker 100% mittig zur Bohrung ausrichten.

The pilots provide great stability and accuracy. If drilling without pilots, please take care, that the countersink is adjusted absolutely centrally to the drilled hole.

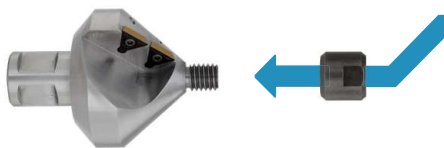

FÜHRUNGSSTIFTE · PILOTS

	• 20 1777 010		• 20 1777 050
	• 20 1777 020		• 20 1777 060
	• 20 1777 030		• 20 1777 070
	• 20 1777 040		

ERSATZTEILE · SPARE PARTS

	Auswechselbare Platten Packnorm 4 Stück Carbide inserts Packing unit 4 pcs.	• 20 1787 110
	4x TORX Befestigungsschrauben Packnorm 4 Stück 4x TORX mounting screw Packing unit 4 pcs.	• 20 1787 120
	1x Befestigungsschlüssel 1x TORX wrench	• 22 9011 0175

- 1
- 2
- 3
- 4
- 5
- 6
- 7
- 8
- 9
- 10

- 1
- 2
- 3
- 4
- 5
- 6
- 7
- 8
- 9
- 10

• **20 1384**

Weldon 19 mm 3/4" DIN 238 B16

• **20 1372**

Fein Quick-In 18 mm DIN 238 B16

• **20 1515**

MORSEKONUS MORSE TAPER 2 DIN 238 B16

• **20 1524**

MORSEKONUS MORSE TAPER 3 DIN 238 B16

• **20 1375**

Selbstspannendes Bohrfutter für Spiralbohrer Ø 1-13 mm

Quick release (keyless) drill chuck for twist drills Ø 1-13 mm



• **20 1525**

DIN 238 B16

Bohrfutter für Spiralbohrer Ø 1-13 mm

Drill chuck for twist drills Ø 1-13 mm

KÜHLMITTEL-DRUCKFLASCHEN · COOLING PRESSURE BOTTLES

Zum Anschluss an alle Aufnahmehalter mit automatischer Innenkühlung (siehe Seite 541-543). Zusätzlich bieten wir eine Sprühnebeldüse an, welche ideal zum äußeren Kühlen geeignet ist.

- Nur wenige Pumpstöße nötig zum idealen Aufbau des Drucks
- Dank großvolumiger 1,5 Liter-Flasche wird der Druck auch bei vielen Bohrungen gehalten
- Durch Feinjustierung, sparsamste Dosierung möglich ①
- Auch ideal zum äußeren Kühlen durch neue Sprühnebeldüse Art. 21 0025!
- Wir empfehlen Karnasch Hochleistungsschneidöl Mecutoil 100 (siehe ab Seite 1265).

For connection to all tool holders with automatic internal cooling (see page 541-543). In addition we offer an atomized nozzle, which is ideal for external cooling.

- You only need to use the pump a few times for obtaining an ideal pressure build-up
- Thanks to the large-volume 1.5 litre bottle the pressure will be maintained even in case of many borings
- Best dosing economy thanks to fine adjustment ①
- Also ideal for external cooling due to the new atomized nozzle Art. 21 0025!
- We recommend Karnasch heavy-duty cutting oil Mecutoil 100 (see from page 1265).

• **21 0025**

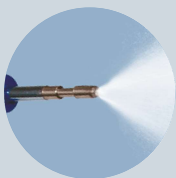

Nur passend für Art. 20 1308
Only suitable for Art. 20 1308

• **20 1308**
1,5 ltr.





21 0001

1. SCHRITT: Nehmen Sie die Metallspäne mit dem Karnasch-Magnetstab auf.

1. STEP: Take the chips with the Karnasch magnetic stick.



2. SCHRITT: Lösen Sie die Späne durch Ziehen des Stabs und des innenliegenden Magneten.

2. STEP: Release the chips by pulling the rod.



1



2



3



4



5



6



7



8



9



10



ERSATZ-INNENSECHSKANTSCHRAUBEN **2** FÜR ADAPTER · SPARE ALLEN SCREWS **2** FOR ADAPTERS



2	Ø mm	Für Adapter Art. · For adapter art.		ART.
	3 mm M 6x6	20 1234	443	• 20 1330
		Gewindeadapter · Tapping adapter	649	
	4 mm M 8x8	20 1421 · 20 1422 · 20 1431 · 20 1434	Diverse · Various	• 20 1343
		Spiralbohradapter · Twist drill adapter	648	
	5 mm M 10x10	20 1161 · 20 1263 · 20 1311 · 20 1314 · 20 1386	Diverse · Various	• 20 1353
	M 6x10	20 1796 040	545	• 20 1455
	Spezial Special	20 1385	Diverse · Various	• 21 0045
	Spezial Special	21 0048	Diverse · Various	• 21 0049



Ersatz-Innensechskantschrauben **2** für Verlängerungen 50 mm, 75 mm, 100 mm.
 Spare allen screws **2** for extensions 50 mm, 75 mm, 100 mm.

2	Ø mm	Für Verlängerungen Artikel For extensions article		Artikel Schraube Article screw
	5 mm M 10x10	20 1387 · 20 1402 · 20 1417 20 1406 · 20 1407 · 20 1409	Diverse Various	• 20 1353

- 1
- 2
- 3
- 4
- 5
- 6
- 7
- 8
- 9
- 10

ERSATZTEILE HALTER · SPARE PARTS HOLDER

21 0002

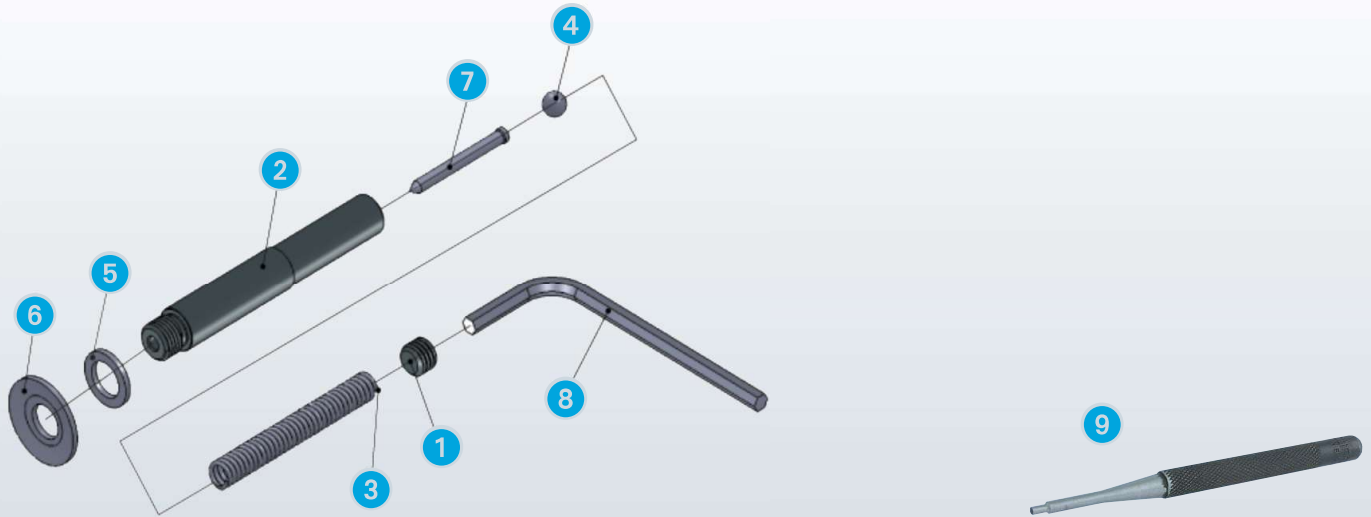

No.	Beschreibung · Description	Art.
1	Inbusschraube · Allen screw	• 21 0004
2	Halter Körper · Arbor body	• 21 0005
3	Auswurfeder · Ejector spring	• 21 0006
4	Stahlkugel · Round steel bead	• 21 0007
5	Unterlegscheibe · Flat washer	• 21 0008
6	Konkave Distanzscheibe · Concave gasket	• 21 0009
7	Auswerferstift · Ejector pin	• 21 0010
8	Inbusschlüssel groß · Allen key big	• 21 0011
9	Körner · Center punch	• 20 1238

Dieser Halter ist geeignet zum Lösen von punktgeschweißten Blechteilen. Die Frästiefe sowie Federdruck ist durch die Schraube 1 einstellbar.
 This arbor is suitable for removing spot welds from sheet metal. Adjustable milling depth and spring force with setting screw 1.

ERSATZTEILE HALTER · SPARE PARTS HOLDER Ø 21-25 mm

21 0003

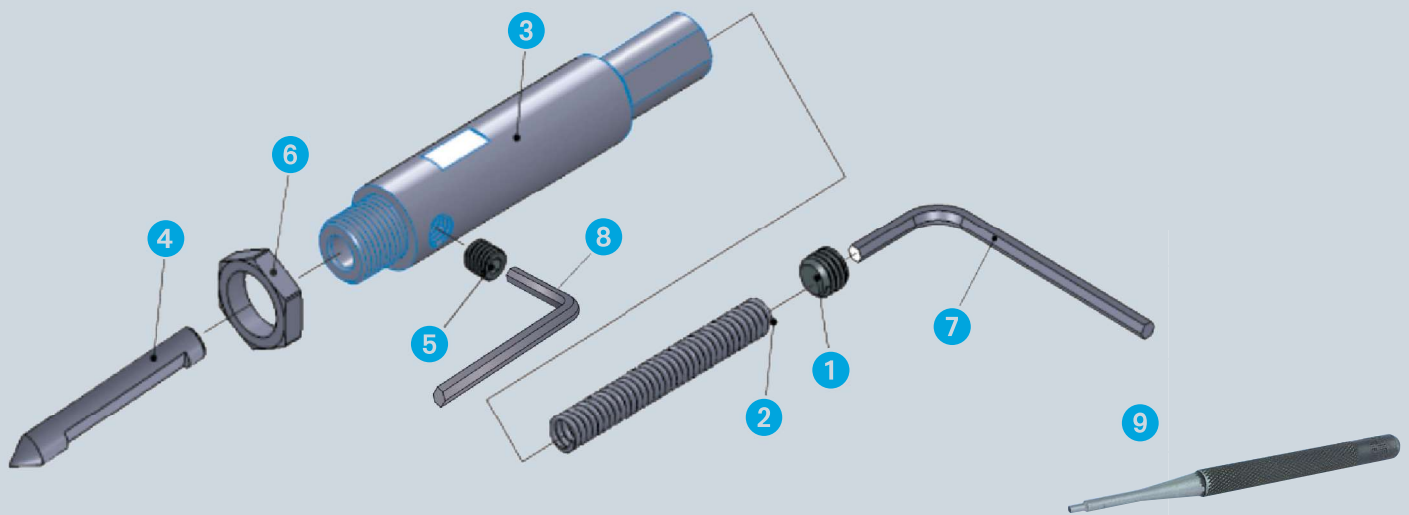

No.	Beschreibung · Description	Art.
1	Inbusschraube · Allen screw	• 21 0012
2	Auswurfeder · Ejector spring	• 21 0013
3	Halter Körper · Arbor body	• 21 0014
4	Auswerferstift · Ejector pin	• 21 0015
5	Inbusschraube · Allen screw	• 21 0016
6	Unterlegscheibe · Flat washer	• 21 0017
7	Inbusschlüssel groß · Allen key big	• 21 0011
8	Inbusschlüssel klein · Allen key small	• 21 0055
9	Körner · Center punch	• 20 1238



- 1
- 2
- 3
- 4
- 5
- 6
- 7
- 8
- 9
- 10

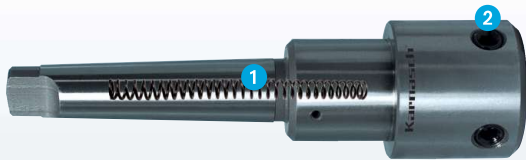

Ersatz-Auswurffeder **1** + Ersatz-Innensechskantschrauben **2** für Aufnahmehalter siehe Katalog Seite 541-543

Ejector spare springs **1** + spare allen screws **2** for tool holders see catalogue page 541-543

1	d1 l1	Für Aufnahmehalter Artikel For tool holders article		Artikel Feder Article spring
	13 x 150 mm	20 1290 · 20 1292 · 20 1289 · 20 1307 · 20 1437	541-543	• 20 1296
	10 x 125 mm	20 1283	541-543	• 20 1297
	14 x 195 mm	20 1291 · 20 1842 · 20 1845 · 20 1846	541-543	• 20 1298
	10 x 133 mm	20 1287 · 20 1303 · 20 1301	541-543	• 20 1299
	13 x 135 mm	20 1293 · 20 1286 · 20 1289 · 20 1310 · 20 1844	541-543	• 20 1294
	13 x 135 mm	20 1400 · 20 1401	357	• 21 0044
	2	Ø mm	Für Aufnahmehalter Artikel For tool holders article	
	6 mm M 12x10	20 1283 · 20 1293 · 20 1287 · 20 1289 · 20 1291	541-543	• 20 1300
	6 mm M 12x12	20 1286 · 20 1290 · 20 1292	541-543	• 20 1305
	-	Diverse · Various	541-543	• 21 0047

20 1346 



Kernbohr-Display Core drilling display

Stellen Sie Ihr individuelles Display zusammen. Wir beraten Sie gerne.
Preise auf Anfrage.

Passende Haken müssen zusätzlich käuflich erworben werden.

Einfachhaken Art. **20 1262**

Doppelhaken Art. **20 1266**

Create your own individual display. We would be pleased to help you.

Prices on request. Suitable hooks must be purchased additionally.

Single hook Art. **20 1262**

Double hook Art. **20 1266**

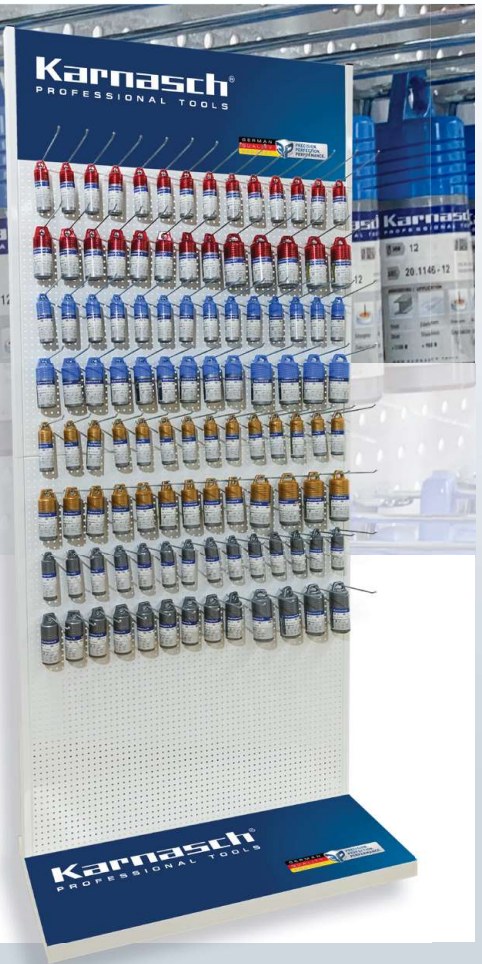

20 1346 



Power-Max Lochsägen-Display Power-Max hole saw display

Stellen Sie Ihr individuelles Display zusammen. Wir beraten Sie gerne.
Preise auf Anfrage.

Passende Haken müssen zusätzlich käuflich erworben werden.

Einfachhaken Art. **20 1262**

Doppelhaken Art. **20 1266**

Create your own individual display. We would be pleased to help you.

Prices on request. Suitable hooks must be purchased additionally.

Single hook Art. **20 1262**

Double hook Art. **20 1266**



- 1 
- 2 
- 3 
- 4 
- 5 
- 6 
- 7 
- 8 
- 9 
- 10 

HARD-LINE 40

SETS / DISPLAYS: INHALT 20 1315
SETS / DISPLAYS: CONTENT 20 1315

**BEST
SELLER**

Lagerprogramm + Zubehör siehe Seite 382-383
Stock range + accessories see page 382-383

- 1 
- 2 
- 3 
- 4 
- 5 
- 6 
- 7 
- 8 
- 9 
- 10 

6
Stück
Pieces

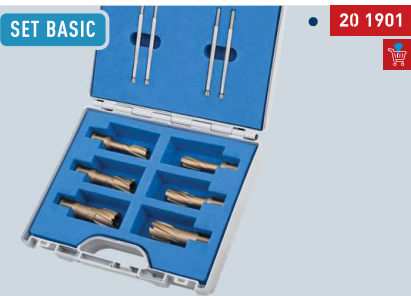

SET BASIC • 20 1901 

Ø 2×14, 2×18, 2×22 mm
4× Auswerferstifte / Ejector pins
Die meistverkauften drei Abmessungen in einem Set
The best selling three dimensions in a set

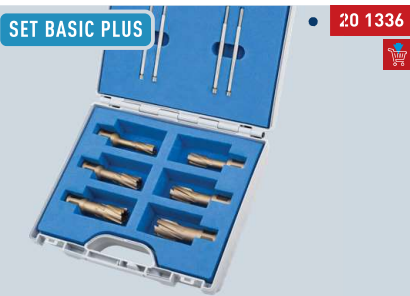

SET BASIC PLUS • 20 1336 

Ø 12, 14, 16, 18, 20, 22 mm
4× Auswerferstifte / Ejector pins
Die BESTSELLER bis Ø 22 mm
BESTSELLER up to Ø 22 mm

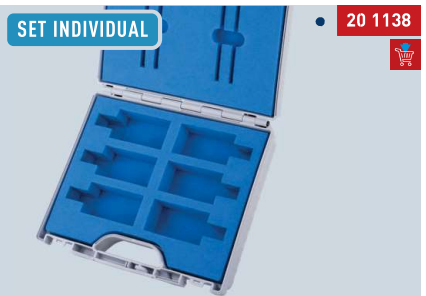

SET INDIVIDUAL • 20 1138 

Leer für max. 6 Kernbohrer + 4 Auswerferstifte.
Max. Ø 40 mm möglich. Gerne stellen wir auch Ihr Wunschset zusammen.
Empty for max. 6 annular cutters + 4 ejector pins.
Maximum possible Ø 40 mm. We also compile your desired set on request.

12
Stück
Pieces



SET PROFI • 20 1902 

Ø 4×14, 4×18, 4×22 mm
4× Auswerferstifte / Ejector pins
Die meistverkauften drei Abmessungen in einem Set
The best selling three dimensions in a set



SET PROFI PLUS • 20 1903 

Ø 2×12, 2×14, 2×16, 2×18, 2×20, 2×22 mm
4× Auswerferstifte / Ejector pins
Die BESTSELLER bis Ø 22 mm
BESTSELLER up to Ø 22 mm

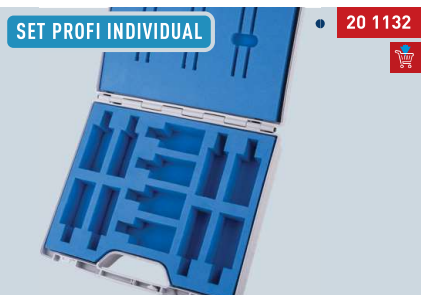

SET PROFI INDIVIDUAL • 20 1132 

Leer für max. 12 Kernbohrer + 4 Auswerferstifte.
Max. Ø 40 mm möglich. Gerne stellen wir auch Ihr Wunschset zusammen.
Empty for max. 12 annular cutters + 4 ejector pins.
Maximum possible Ø 40 mm. We also compile your desired set on request.

≤ 50
Stück
Pieces

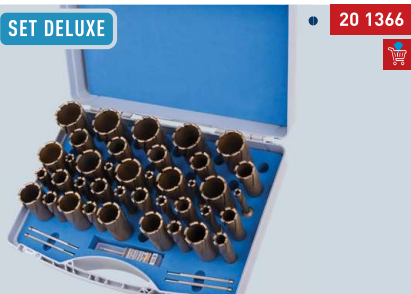

SET DELUXE • 20 1366 

Das komplette Sortiment 12–50 mm in 1,0 mm aufsteigend (39 Stück)
The hole range 12–50 mm in 1,0 mm steps (39 pieces)
6× Auswerferstifte / Ejector pins



SET DELUXE PLUS • 20 1904 

Ø 4×12, 2×13, 4×14, 2×15, 4×16, 2×17, 4×18, 2×19, 4×20, 4×22, 2×23, 2×24, 4×25, 2×26, 2×27, 2×28, 2×30, 2×32 mm
6× Auswerferstifte / Ejector pins
Die BESTSELLER bis Ø 32 mm
BESTSELLER up to Ø 32 mm



SET DELUXE INDIVIDUAL • 20 1139 

Leer für max. 50 Kernbohrer bis Ø 120 mm möglich.
Anzahl der Auswerferstifte nach Wunsch. Gerne stellen wir auch Ihr Wunschset zusammen.
Empty for max. 50 annular cutters. Maximum possible Ø 120 mm. Quantity ejector pins on request. We also compile your desired set on request.

44
Stück
Pieces

Abschließbares Acryldisplay
Ideal als Showcase und Mini-Lager. Alle gängigen Abmessungen sofort sichtbar und griffbereit.

Lockable acrylic display
Ideal as showcase and small warehouse. All current sizes directly visible and available.



DISPLAY • 20 1604 

Ø 2×12, 2×13, 2×14, 2×15, 2×16, 2×17, 2×18, 2×19, 2×20, 2×21, 2×22, 2×23, 2×24, 2×25, 2×26, 2×27, 2×28, 2×30, 2×32, 1×33, 1×35, 1×36, 1×40, 1×45, 1×50 mm
6× Auswerferstifte / Ejector pins
Die BESTSELLER bis Ø 50 mm
BESTSELLER up to Ø 50 mm



DISPLAY INDIVIDUAL • 20 1344 

Leer für max. 44 Kernbohrer bis Ø 60 mm möglich.
Anzahl der Auswerferstifte nach Wunsch. Gerne stellen wir auch Ihr Wunschset zusammen.
Empty for max. 44 annular cutters. Maximum possible Ø 60 mm. Quantity ejector pins on request. We also compile your desired set on request.

HARD-LINE 55

SETS / DISPLAYS: INHALT 20 1316
SETS / DISPLAYS: CONTENT 20 1316

**BEST
SELLER**

Lagerprogramm + Zubehör siehe Seite 384-385
Stock range + accessories see page 384-385

**6
Stück
Pieces**



• 20 1905

Ø 2×14, 2×18, 2×22 mm
4x Auswerferstifte / Ejector pins
Die meistverkauften drei Abmessungen in einem Set
The best selling three dimensions in a set



• 20 1339

Ø 14, 16, 18, 20, 22, 26 mm
4x Auswerferstifte / Ejector pins
Die BESTSELLER bis Ø 26 mm
BESTSELLER up to Ø 26 mm

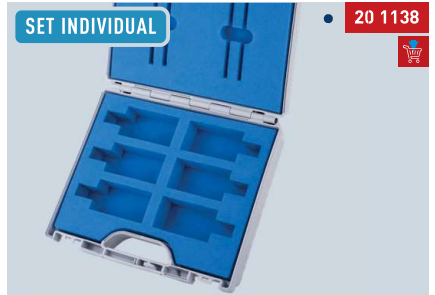

• 20 1138

Leer für max. 6 Kernbohrer + 4 Auswerferstifte.
Max. Ø 40 mm möglich. Gerne stellen wir auch Ihr Wunschset zusammen.
Empty for max. 6 annular cutters + 4 ejector pins.
Maximum possible Ø 40 mm. We also compile your desired set on request.

**12
Stück
Pieces**



• 20 1906

Ø 3×14, 3×18, 3×22, 3×26 mm
4x Auswerferstifte / Ejector pins
Die meistverkauften vier Abmessungen in einem Set
The best selling four dimensions in a set



• 20 1907

Ø 2×14, 2×16, 2×18, 2×20, 2×22, 2×26 mm
4x Auswerferstifte / Ejector pins
Die BESTSELLER bis Ø 26 mm
BESTSELLER up to Ø 26 mm



• 20 1132

Leer für max. 12 Kernbohrer + 4 Auswerferstifte.
Max. Ø 40 mm möglich. Gerne stellen wir auch Ihr Wunschset zusammen.
Empty for max. 12 annular cutters + 4 ejector pins.
Maximum possible Ø 40 mm. We also compile your desired set on request.

**≤ 50
Stück
Pieces**

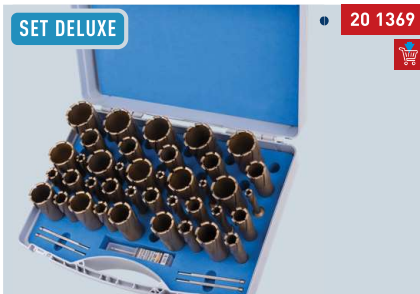

• 20 1369

Das komplette Sortiment 12-50 mm in 1,0 mm aufsteigend (39 Stück)
The hole range 12-50 mm in 1,0 mm steps (39 pieces)
6x Auswerferstifte / Ejector pins



• 20 1908

Ø 2×12, 2×13, 4×14, 2×15, 2×16, 2×17, 4×18, 2×19, 4×20, 4×22, 4×23, 2×24, 4×25, 4×26, 2×27, 2×28, 2×30, 2×32 mm
6x Auswerferstifte / Ejector pins
Die BESTSELLER bis Ø 32 mm
BESTSELLER up to Ø 32 mm



• 20 1139

Leer für max. 50 Kernbohrer bis Ø 120 mm möglich.
Anzahl der Auswerferstifte nach Wunsch. Gerne stellen wir auch Ihr Wunschset zusammen.
Empty for max. 50 annular cutters. Maximum possible Ø 120 mm. Quantity ejector pins on request. We also compile your desired set on request.

**44
Stück
Pieces**

Abschließbares Acryldisplay
Ideal als Showcase und Mini-Lager. Alle gängigen Abmessungen sofort sichtbar und griffbereit.

Lockable acrylic display
Ideal as showcase and small warehouse. All current sizes directly visible and available.



• 20 1624

Ø 2×12, 2×13, 2×14, 2×15, 2×16, 2×17, 2×18, 2×19, 2×20, 2×21, 2×22, 2×23, 2×24, 2×25, 2×26, 2×27, 2×28, 2×30, 2×32, 1×33, 1×35, 1×36, 1×40, 1×45, 1×50 mm
6x Auswerferstifte / Ejector pins
Die BESTSELLER bis Ø 50 mm
BESTSELLER up to Ø 50 mm



• 20 1344

Leer für max. 44 Kernbohrer bis Ø 60 mm möglich.
Anzahl der Auswerferstifte nach Wunsch. Gerne stellen wir auch Ihr Wunschset zusammen.
Empty for max. 44 annular cutters. Maximum possible Ø 60 mm. Quantity ejector pins on request. We also compile your desired set on request.

- 1
- 2
- 3
- 4
- 5
- 6
- 7
- 8
- 9
- 10

HARD-LINE
ZOLL / INCH

40

SETS / DISPLAYS: INHALT 20 1930
SETS / DISPLAYS: CONTENT 20 1930

Lagerprogramm + Zubehör siehe Seite 392-393
Stock range + accessories see page 392-393

- 1 
- 2 
- 3 
- 4 
- 5 
- 6 
- 7 
- 8 
- 9 
- 10 

6 Stück Pieces

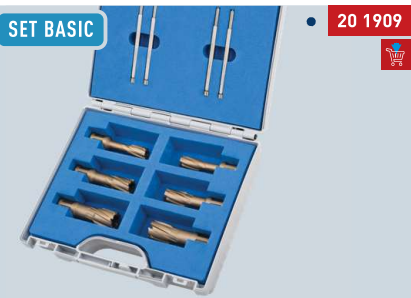

SET BASIC • 20 1909 

Ø 2x 5/8", 2x 13/16", 2x 15/16"
4x Auswerferstifte / Ejector pins
Die meistverkauften drei Abmessungen in einem Set
The best selling three dimensions in a set

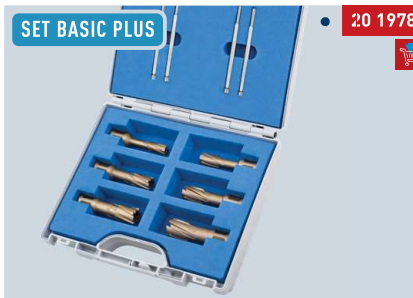

SET BASIC PLUS • 20 1978 

Ø 9/16", 5/8", 3/4", 13/16", 15/16", 1.1/16"
4x Auswerferstifte / Ejector pins
Die BESTSELLER bis Ø 1.1/16"
BESTSELLER up to Ø 1.1/16"

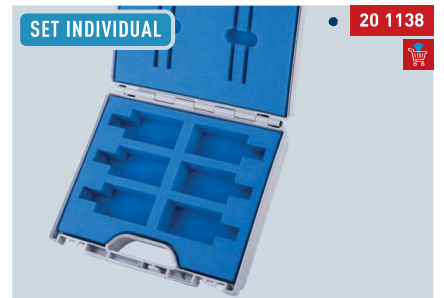

SET INDIVIDUAL • 20 1138 

Leer für max. 6 Kernbohrer + 4 Auswerferstifte.
Max. Ø 40 mm möglich. Gerne stellen wir auch Ihr Wunschset zusammen.
Empty for max. 6 annular cutters + 4 ejector pins.
Maximum possible Ø 40 mm. We also compile your desired set on request.

12 Stück Pieces



SET PROFI • 20 1911 

Ø 4x 5/8", 4x 13/16", 4x 15/16"
4x Auswerferstifte / Ejector pins
Die meistverkauften drei Abmessungen in einem Set
The best selling three dimensions in a set



SET PROFI PLUS • 20 1914 

Ø 2x 9/16", 2x 5/8", 2x 3/4", 2x 13/16", 2x 15/16",
2x 1.1/16"
4x Auswerferstifte / Ejector pins
Die BESTSELLER bis Ø 1.1/16"
BESTSELLER up to Ø 1.1/16"

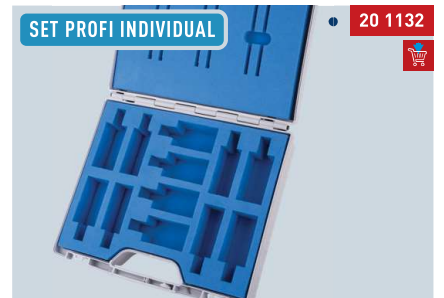

SET PROFI INDIVIDUAL • 20 1132 

Leer für max. 12 Kernbohrer + 4 Auswerferstifte.
Max. Ø 40 mm möglich. Gerne stellen wir auch Ihr Wunschset zusammen.
Empty for max. 12 annular cutters + 4 ejector pins.
Maximum possible Ø 40 mm. We also compile your desired set on request.

≤ 50 Stück Pieces

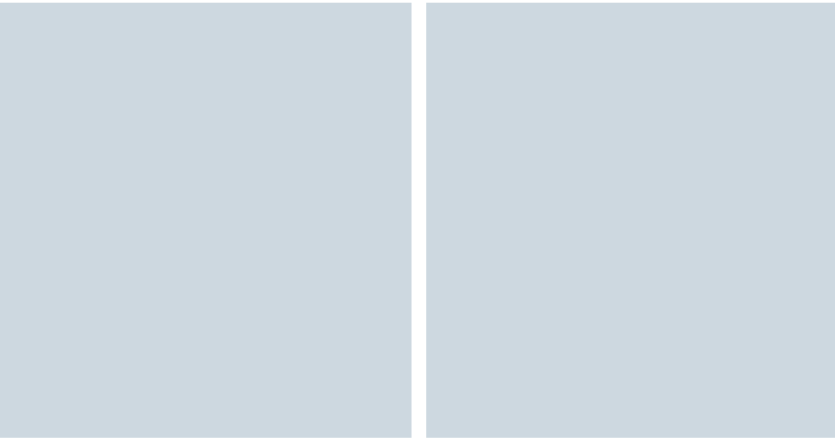

SET DELUXE INDIVIDUAL • 20 1139 

Leer für max. 50 Kernbohrer bis Ø 120 mm möglich.
Anzahl der Auswerferstifte nach Wunsch. Gerne stellen wir auch Ihr Wunschset zusammen.
Empty for max. 50 annular cutters. Maximum possible Ø 120 mm. Quantity ejector pins on request. We also compile your desired set on request.

44 Stück Pieces

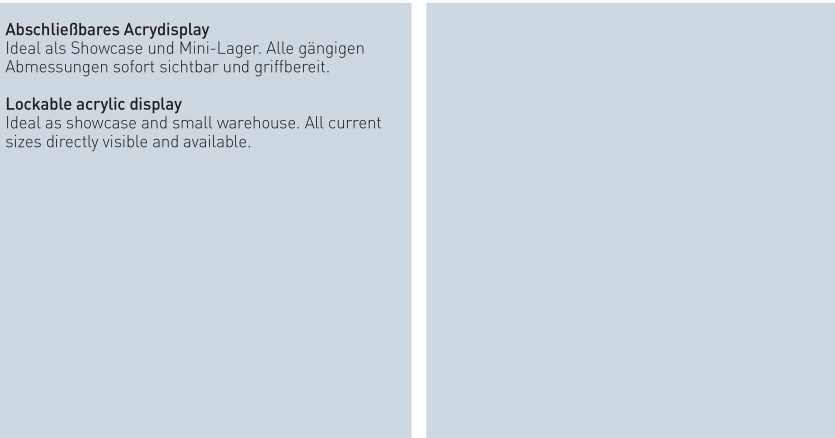

Abschließbares Acryldisplay
Ideal als Showcase und Mini-Lager. Alle gängigen Abmessungen sofort sichtbar und griffbereit.
Lockable acrylic display
Ideal as showcase and small warehouse. All current sizes directly visible and available.



DISPLAY INDIVIDUAL • 20 1344 

Leer für max. 44 Kernbohrer bis Ø 60 mm möglich.
Anzahl der Auswerferstifte nach Wunsch. Gerne stellen wir auch Ihr Wunschset zusammen.
Empty for max. 44 annular cutters. Maximum possible Ø 60 mm. Quantity ejector pins on request. We also compile your desired set on request.

HARD-LINE
ZOLL / INCH **55**

SETS / DISPLAYS: INHALT 20 1940
SETS / DISPLAYS: CONTENT 20 1940

Lagerprogramm + Zubehör siehe Seite 394-395
Stock range + accessories see page 394-395

6
Stück
Pieces



• 20 1915

Ø 2× 13/16", 2× 15/16", 2× 1.1/16"
2× Auswerferstifte / Ejector pins
Die meistverkauften drei Abmessungen in einem Set
The best selling three dimensions in a set



• 20 1979

Ø 5/8", 11/16", 3/4", 13/16", 15/16", 1.1/16"
4× Auswerferstifte / Ejector pins
Die BESTSELLER bis Ø 1.1/16"
BESTSELLER up to Ø 1.1/16"

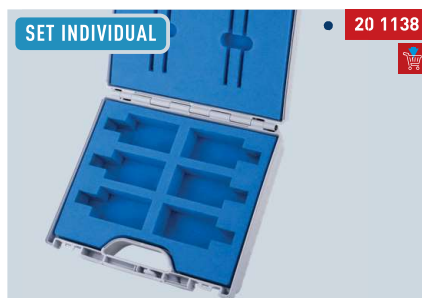

• 20 1138

Leer für max. 6 Kernbohrer + 4 Auswerferstifte.
Max. Ø 40 mm möglich. Gerne stellen wir auch Ihr Wunschset zusammen.
Empty for max. 6 annular cutters + 4 ejector pins.
Maximum possible Ø 40 mm. We also compile your desired set on request.

12
Stück
Pieces

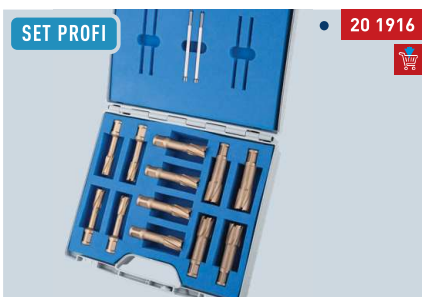

• 20 1916

Ø 4× 13/16", 4× 15/16", 4× 1.1/16"
2× Auswerferstifte / Ejector pins
Die meistverkauften drei Abmessungen in einem Set
The best selling three dimensions in a set



• 20 1917

Ø 2× 5/8", 2× 11/16", 2× 3/4", 2× 13/16", 2× 15/16",
2× 1.1/16"
4× Auswerferstifte / Ejector pins
Die BESTSELLER bis Ø 1.1/16"
BESTSELLER up to Ø 1.1/16"



• 20 1132

Leer für max. 12 Kernbohrer + 4 Auswerferstifte.
Max. Ø 40 mm möglich. Gerne stellen wir auch Ihr Wunschset zusammen.
Empty for max. 12 annular cutters + 4 ejector pins.
Maximum possible Ø 40 mm. We also compile your desired set on request.

≤ 50
Stück
Pieces

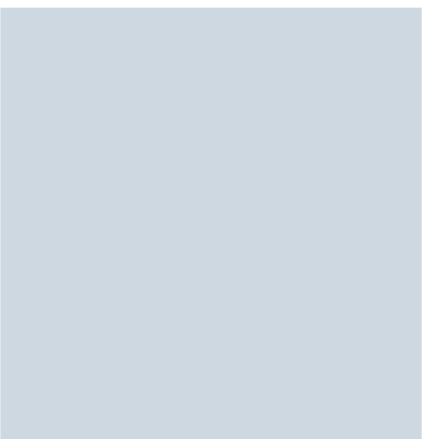
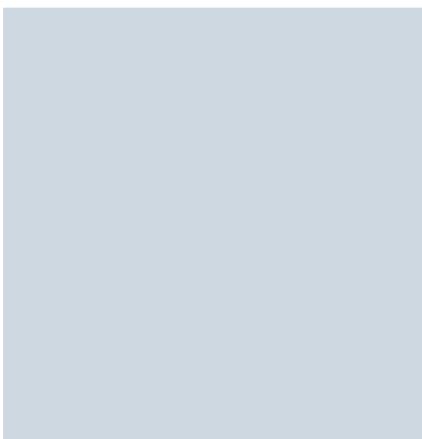

• 20 1139

Leer für max. 50 Kernbohrer bis Ø 120 mm möglich.
Anzahl der Auswerferstifte nach Wunsch. Gerne stellen wir auch Ihr Wunschset zusammen.
Empty for max. 50 annular cutters. Maximum possible Ø 120 mm. Quantity ejector pins on request. We also compile your desired set on request.

44
Stück
Pieces

Abschließbares Acryldisplay
Ideal als Showcase und Mini-Lager. Alle gängigen Abmessungen sofort sichtbar und griffbereit.

Lockable acrylic display
Ideal as showcase and small warehouse. All current sizes directly visible and available.

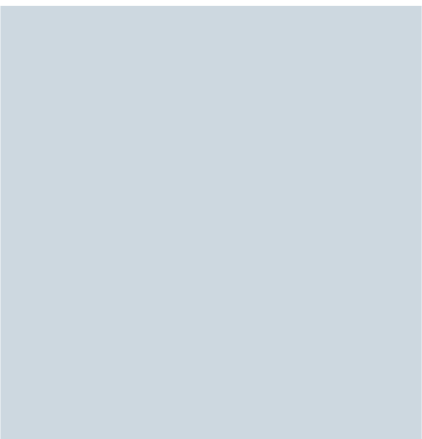

• 20 1344

Leer für max. 44 Kernbohrer bis Ø 60 mm möglich.
Anzahl der Auswerferstifte nach Wunsch. Gerne stellen wir auch Ihr Wunschset zusammen.
Empty for max. 44 annular cutters. Maximum possible Ø 60 mm. Quantity ejector pins on request. We also compile your desired set on request.

- 1
- 2
- 3
- 4
- 5
- 6
- 7
- 8
- 9
- 10

BLUE-DRILL LINE 30 PRO

SETS / DISPLAYS: INHALT 20 1284

Lagerprogramm + Zubehör siehe Seite 406-407 + 530-531

BLUE-DRILL LINE RAIL 30 PRO

SETS / DISPLAYS: CONTENT 20 1284

Stock range + accessories see page 406-407 + 530-531

SET BASIC

• 20 1944

6 Stück Pieces

Ø 2×12, 2×16, 2×18 mm
2× Auswerferstifte / Ejector pins
Die meistverkauften drei Abmessungen in einem Set
The best selling three dimensions in a set

SET BASIC PLUS

• 20 1331

Ø 12, 14, 16, 18, 20, 26 mm
2× Auswerferstifte / Ejector pins
Die BESTSELLER bis Ø 26 mm
BESTSELLER up to Ø 26 mm

SET INDIVIDUAL

• 20 1138

Leer für max. 6 Kernbohrer + 4 Auswerferstifte.
Max. Ø 40 mm möglich. Gerne stellen wir auch Ihr Wunschset zusammen.
Empty for max. 6 annular cutters + 4 ejector pins.
Maximum possible Ø 40 mm. We also compile your desired set on request.

SET PROFI

• 20 1945

12 Stück Pieces

Ø 3×12, 3×14, 3×16, 3×18 mm
2× Auswerferstifte / Ejector pins
Die meistverkauften vier Abmessungen in einem Set
The best selling four dimensions in a set

SET PROFI PLUS

• 20 1946

Ø 2×12, 2×14, 2×16, 2×18, 2×20, 2×26 mm
2× Auswerferstifte / Ejector pins
Die BESTSELLER bis Ø 26 mm
BESTSELLER up to Ø 26 mm

SET PROFI INDIVIDUAL

• 20 1132

Leer für max. 12 Kernbohrer + 4 Auswerferstifte.
Max. Ø 40 mm möglich. Gerne stellen wir auch Ihr Wunschset zusammen.
Empty for max. 12 annular cutters + 4 ejector pins.
Maximum possible Ø 40 mm. We also compile your desired set on request.

SET DELUXE INDIVIDUAL

• 20 1139

Leer für max. 50 Kernbohrer bis Ø 120 mm möglich.
Anzahl der Auswerferstifte nach Wunsch. Gerne stellen wir auch Ihr Wunschset zusammen.
Empty for max. 50 annular cutters. Maximum possible Ø 120 mm. Quantity ejector pins on request. We also compile your desired set on request.

DISPLAY INDIVIDUAL

• 20 1344

Leer für max. 44 Kernbohrer bis Ø 60 mm möglich.
Anzahl der Auswerferstifte nach Wunsch. Gerne stellen wir auch Ihr Wunschset zusammen.
Empty for max. 44 annular cutters. Maximum possible Ø 60 mm. Quantity ejector pins on request. We also compile your desired set on request.

Abschließbares Acryldisplay
Ideal als Showcase und Mini-Lager. Alle gängigen Abmessungen sofort sichtbar und griffbereit.

Lockable acrylic display
Ideal as showcase and small warehouse. All current sizes directly visible and available.

44 Stück Pieces

BLUE-DRILL LINE **55** PRO
BLUE-DRILL LINE RAIL **55** PRO

SETS / DISPLAYS: INHALT 20 1317
 SETS / DISPLAYS: CONTENT 20 1317

Lagerprogramm + Zubehör siehe Seite 408-409 + 532-533
 Stock range + accessories see page 408-409 + 532-533

6 Stück Pieces

SET BASIC • 20 1947



Ø 2×14, 2×18, 2×20 mm
 2× Auswerferstifte / Ejector pins
 Die meistverkauften drei Abmessungen in einem Set
 The best selling three dimensions in a set

SET BASIC PLUS • 20 1334



Ø 12, 14, 16, 18, 20, 26 mm
 2× Auswerferstifte / Ejector pins
 Die BESTSELLER bis Ø 26 mm
 BESTSELLER up to Ø 26 mm

SET INDIVIDUAL • 20 1138



Leer für max. 6 Kernbohrer + 4 Auswerferstifte.
 Max. Ø 40 mm möglich. Gerne stellen wir auch Ihr Wunschset zusammen.
Empty for max. 6 annular cutters + 4 ejector pins.
 Maximum possible Ø 40 mm. We also compile your desired set on request.

12 Stück Pieces

SET PROFI • 20 1948



Ø 3×14, 3×18, 3×20, 3×26 mm
 2× Auswerferstifte / Ejector pins
 Die meistverkauften vier Abmessungen in einem Set
 The best selling four dimensions in a set

SET PROFI PLUS • 20 1949



Ø 2×12, 2×14, 2×16, 2×18, 2×20, 2×26 mm
 2× Auswerferstifte / Ejector pins
 Die BESTSELLER bis Ø 26 mm
 BESTSELLER up to Ø 26 mm

SET PROFI INDIVIDUAL • 20 1132



Leer für max. 12 Kernbohrer + 4 Auswerferstifte.
 Max. Ø 40 mm möglich. Gerne stellen wir auch Ihr Wunschset zusammen.
Empty for max. 12 annular cutters + 4 ejector pins.
 Maximum possible Ø 40 mm. We also compile your desired set on request.

≤ 50 Stück Pieces

SET DELUXE INDIVIDUAL • 20 1139



Leer für max. 50 Kernbohrer bis Ø 120 mm möglich.
 Anzahl der Auswerferstifte nach Wunsch. Gerne stellen wir auch Ihr Wunschset zusammen.
Empty for max. 50 annular cutters. Maximum possible Ø 120 mm. Quantity ejector pins on request. We also compile your desired set on request.

DISPLAY INDIVIDUAL • 20 1344



Leer für max. 44 Kernbohrer bis Ø 60 mm möglich.
 Anzahl der Auswerferstifte nach Wunsch. Gerne stellen wir auch Ihr Wunschset zusammen.
Empty for max. 44 annular cutters. Maximum possible Ø 60 mm. Quantity ejector pins on request. We also compile your desired set on request.

44 Stück Pieces

Abschließbares Acryldisplay
 Ideal als Showcase und Mini-Lager. Alle gängigen Abmessungen sofort sichtbar und griffbereit.

Lockable acrylic display
 Ideal as showcase and small warehouse. All current sizes directly visible and available.

DISPLAY INDIVIDUAL • 20 1344



Leer für max. 44 Kernbohrer bis Ø 60 mm möglich.
 Anzahl der Auswerferstifte nach Wunsch. Gerne stellen wir auch Ihr Wunschset zusammen.
Empty for max. 44 annular cutters. Maximum possible Ø 60 mm. Quantity ejector pins on request. We also compile your desired set on request.

- 1 
- 2 
- 3 
- 4 
- 5 
- 6 
- 7 
- 8 
- 9 
- 10 

BLUE-DRILL LINE 30

SETS / DISPLAYS: INHALT 20 1312
SETS / DISPLAYS: CONTENT 20 1312

**BEST
SELLER**

Lagerprogramm + Zubehör siehe Seite 412-413
Stock range + accessories see page 412-413

- 1
- 2
- 3
- 4
- 5
- 6
- 7
- 8
- 9
- 10

**6
Stück
Pieces**

SET BASIC • **20 1950**

Ø 2x14, 2x18, 2x22 mm
2x Auswerferstifte / Ejector pins
Die meistverkauften drei Abmessungen in einem Set
The best selling three dimensions in a set

SET BASIC PLUS • **20 1325**

Ø 12, 14, 16, 18, 20, 22 mm
2x Auswerferstifte / Ejector pins
Die BESTSELLER bis Ø 22 mm
BESTSELLER up to Ø 22 mm

SET INDIVIDUAL • **20 1138**

Leer für max. 6 Kernbohrer + 4 Auswerferstifte.
Max. Ø 40 mm möglich. Gerne stellen wir auch Ihr Wunschset zusammen.
Empty for max. 6 annular cutters + 4 ejector pins.
Maximum possible Ø 40 mm. We also compile your desired set on request.

**12
Stück
Pieces**

SET PROFI • **20 1951**

Ø 3x12, 3x14, 3x18, 3x22 mm
2x Auswerferstifte / Ejector pins
Die meistverkauften vier Abmessungen in einem Set
The best selling four dimensions in a set

SET PROFI PLUS • **20 1952**

Ø 2x12, 2x14, 2x16, 2x18, 2x20, 2x22 mm
2x Auswerferstifte / Ejector pins
Die BESTSELLER bis Ø 22 mm
BESTSELLER up to Ø 22 mm

SET PROFI INDIVIDUAL • **20 1132**

Leer für max. 12 Kernbohrer + 4 Auswerferstifte.
Max. Ø 40 mm möglich. Gerne stellen wir auch Ihr Wunschset zusammen.
Empty for max. 12 annular cutters + 4 ejector pins.
Maximum possible Ø 40 mm. We also compile your desired set on request.

**≤ 50
Stück
Pieces**

SET DELUXE • **20 1360**

Das komplette Sortiment 12–50 mm in 1,0 mm aufsteigend (39 Stück)
The hole range 12–50 mm in 1,0 mm steps (39 pieces)
6x Auswerferstifte / Ejector pins

SET DELUXE PLUS • **20 1953**

Ø 4x12, 2x13, 4x14, 2x15, 4x16, 2x17, 4x18, 2x19, 4x20, 4x22, 2x23, 2x24, 2x25, 4x26, 2x27, 2x28, 2x30, 2x32 mm
6x Auswerferstifte / Ejector pins
Die BESTSELLER bis Ø 32 mm
BESTSELLER up to Ø 32 mm

SET DELUXE INDIVIDUAL • **20 1139**

Leer für max. 50 Kernbohrer bis Ø 120 mm möglich.
Anzahl der Auswerferstifte nach Wunsch. Gerne stellen wir auch Ihr Wunschset zusammen.
Empty for max. 50 annular cutters. Maximum possible Ø 120 mm. Quantity ejector pins on request. We also compile your desired set on request.

**44
Stück
Pieces**

Abschließbares Acryldisplay
Ideal als Showcase und Mini-Lager. Alle gängigen Abmessungen sofort sichtbar und griffbereit.

Lockable acrylic display
Ideal as showcase and small warehouse. All current sizes directly visible and available.

DISPLAY • **20 1603**

Ø 2x12, 2x13, 2x14, 2x15, 2x16, 2x17, 2x18, 2x19, 2x20, 2x21, 2x22, 2x23, 2x24, 2x25, 2x26, 2x27, 2x28, 2x30, 2x32, 1x33, 1x35, 1x36, 1x40, 1x45, 1x50 mm
6x Auswerferstifte / Ejector pins
Die BESTSELLER bis Ø 50 mm
BESTSELLER up to Ø 50 mm

DISPLAY INDIVIDUAL • **20 1344**

Leer für max. 44 Kernbohrer bis Ø 60 mm möglich.
Anzahl der Auswerferstifte nach Wunsch. Gerne stellen wir auch Ihr Wunschset zusammen.
Empty for max. 44 annular cutters. Maximum possible Ø 60 mm. Quantity ejector pins on request. We also compile your desired set on request.

BLUE-DRILL LINE/55

SETS / DISPLAYS: INHALT 20 1313
SETS / DISPLAYS: CONTENT 20 1313

**BEST
SELLER**

Lagerprogramm + Zubehör siehe Seite 414-415
Stock range + accessories see page 414-415

6 Stück Pieces

SET BASIC • 20 1954



Ø 2×14, 2×18, 2×22 mm
2× Auswerferstifte / Ejector pins
Die meistverkauften drei Abmessungen in einem Set
The best selling three dimensions in a set

SET BASIC PLUS • 20 1328



Ø 14, 16, 18, 20, 22, 26 mm
2× Auswerferstifte / Ejector pins
Die BESTSELLER bis Ø 26 mm
BESTSELLER up to Ø 26 mm

SET INDIVIDUAL • 20 1138



Leer für max. 6 Kernbohrer + 4 Auswerferstifte.
Max. Ø 40 mm möglich. Gerne stellen wir auch Ihr Wunschset zusammen.
Empty for max. 6 annular cutters + 4 ejector pins.
Maximum possible Ø 40 mm. We also compile your desired set on request.

12 Stück Pieces

SET PROFI • 20 1955

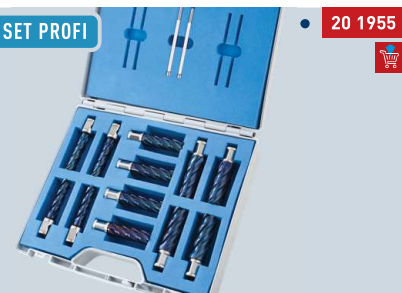

Ø 4×14, 4×18, 4×22 mm
2× Auswerferstifte / Ejector pins
Die meistverkauften drei Abmessungen in einem Set
The best selling three dimensions in a set

SET PROFI PLUS • 20 1956



Ø 2×14, 2×16, 2×18, 2×20, 2×22, 2×26 mm
2× Auswerferstifte / Ejector pins
Die BESTSELLER bis Ø 26 mm
BESTSELLER up to Ø 26 mm

SET PROFI INDIVIDUAL • 20 1132



Leer für max. 12 Kernbohrer + 4 Auswerferstifte.
Max. Ø 40 mm möglich. Gerne stellen wir auch Ihr Wunschset zusammen.
Empty for max. 12 annular cutters + 4 ejector pins.
Maximum possible Ø 40 mm. We also compile your desired set on request.

≤ 50 Stück Pieces

SET DELUXE • 20 1363



Das komplette Sortiment 12-50 mm in 1,0 mm aufsteigend (39 Stück)
The hole range 12-50 mm in 1,0 mm steps (39 pieces)
6× Auswerferstifte / Ejector pins

SET DELUXE PLUS • 20 1957



Ø 4×12, 2×13, 4×14, 2×15, 4×16, 2×17, 4×18, 2×19, 4×20, 2×21, 4×22, 2×24, 2×25, 4×26, 2×27, 2×28, 2×30, 2×32 mm
6× Auswerferstifte / Ejector pins
Die BESTSELLER bis Ø 32 mm
BESTSELLER up to Ø 32 mm

SET DELUXE INDIVIDUAL • 20 1139



Leer für max. 50 Kernbohrer bis Ø 120 mm möglich.
Anzahl der Auswerferstifte nach Wunsch. Gerne stellen wir auch Ihr Wunschset zusammen.
Empty for max. 50 annular cutters. Maximum possible Ø 120 mm. Quantity ejector pins on request. We also compile your desired set on request.

44 Stück Pieces

Abschließbares Acryldisplay
Ideal als Showcase und Mini-Lager. Alle gängigen Abmessungen sofort sichtbar und griffbereit.

Lockable acrylic display
Ideal as showcase and small warehouse. All current sizes directly visible and available.

DISPLAY • 20 1609



Ø 2×12, 2×13, 2×14, 2×15, 2×16, 2×17, 2×18, 2×19, 2×20, 2×21, 2×22, 2×23, 2×24, 2×25, 2×26, 2×27, 2×28, 2×30, 2×32, 1×33, 1×35, 1×36, 1×40, 1×45, 1×50 mm
6× Auswerferstifte / Ejector pins
Die BESTSELLER bis Ø 50 mm
BESTSELLER up to Ø 50 mm

DISPLAY INDIVIDUAL • 20 1344



Leer für max. 44 Kernbohrer bis Ø 60 mm möglich.
Anzahl der Auswerferstifte nach Wunsch. Gerne stellen wir auch Ihr Wunschset zusammen.
Empty for max. 44 annular cutters. Maximum possible Ø 60 mm. Quantity ejector pins on request. We also compile your desired set on request.

- 1 
- 2 
- 3 
- 4 
- 5 
- 6 
- 7 
- 8 
- 9 
- 10 

GOLD-DRILL LINE 30

SETS / DISPLAYS: INHALT 20 1260U
SETS / DISPLAYS: CONTENT 20 1260U

**BEST
SELLER**

Lagerprogramm + Zubehör siehe Seite 422-423
Stock range + accessories see page 422-423

- 1
- 2
- 3
- 4
- 5
- 6
- 7
- 8
- 9
- 10

**6
Stück
Pieces**

SET BASIC • 20 1967



Ø 2x14, 2x18, 2x22 mm
2x Auswerferstifte / Ejector pins
Die meistverkauften drei Abmessungen in einem Set
The best selling three dimensions in a set

SET BASIC PLUS • 20 1322



Ø 12, 14, 16, 18, 20, 22 mm
2x Auswerferstifte / Ejector pins
Die BESTSELLER bis Ø 22 mm
BESTSELLER up to Ø 22 mm

SET INDIVIDUAL • 20 1138



Leer für max. 6 Kernbohrer + 4 Auswerferstifte.
Max. Ø 40 mm möglich. Gerne stellen wir auch Ihr Wunschset zusammen.
Empty for max. 6 annular cutters + 4 ejector pins.
Maximum possible Ø 40 mm. We also compile your desired set on request.

**12
Stück
Pieces**

SET PROFI • 20 1968



Ø 3x12, 3x14, 3x18, 3x22 mm
2x Auswerferstifte / Ejector pins
Die meistverkauften vier Abmessungen in einem Set
The best selling four dimensions in a set

SET PROFI PLUS • 20 1969



Ø 2x12, 2x14, 2x16, 2x18, 2x20, 2x22 mm
2x Auswerferstifte / Ejector pins
Die BESTSELLER bis Ø 22 mm
BESTSELLER up to Ø 22 mm

SET PROFI INDIVIDUAL • 20 1132



Leer für max. 12 Kernbohrer + 4 Auswerferstifte.
Max. Ø 40 mm möglich. Gerne stellen wir auch Ihr Wunschset zusammen.
Empty for max. 12 annular cutters + 4 ejector pins.
Maximum possible Ø 40 mm. We also compile your desired set on request.

**≤ 50
Stück
Pieces**

SET DELUXE • 20 1361



Das komplette Sortiment 12–50 mm in 1,0 mm aufsteigend (39 Stück)
The hole range 12–50 mm in 1,0 mm steps (39 pieces)
6x Auswerferstifte / Ejector pins

SET DELUXE PLUS • 20 1971



Ø 4x12, 2x13, 4x14, 2x15, 4x16, 2x17, 4x18, 2x19, 4x20, 4x22, 2x23, 2x24, 2x25, 4x26, 2x27, 2x28, 2x30, 2x32 mm
6x Auswerferstifte / Ejector pins
Die BESTSELLER bis Ø 32 mm
BESTSELLER up to Ø 32 mm

SET DELUXE INDIVIDUAL • 20 1139



Leer für max. 50 Kernbohrer bis Ø 120 mm möglich.
Anzahl der Auswerferstifte nach Wunsch. Gerne stellen wir auch Ihr Wunschset zusammen.
Empty for max. 50 annular cutters. Maximum possible Ø 120 mm. Quantity ejector pins on request. We also compile your desired set on request.

**44
Stück
Pieces**

Abschließbares Acryldisplay
Ideal als Showcase und Mini-Lager. Alle gängigen Abmessungen sofort sichtbar und griffbereit.

Lockable acrylic display
Ideal as showcase and small warehouse. All current sizes directly visible and available.

DISPLAY • 20 1602



Ø 2x12, 2x13, 2x14, 2x15, 2x16, 2x17, 2x18, 2x19, 2x20, 2x21, 2x22, 2x23, 2x24, 2x25, 2x26, 2x27, 2x28, 2x30, 2x32, 1x33, 1x35, 1x36, 1x40, 1x45, 1x50 mm
6x Auswerferstifte / Ejector pins
Die BESTSELLER bis Ø 50 mm
BESTSELLER up to Ø 50 mm

DISPLAY INDIVIDUAL • 20 1344



Leer für max. 44 Kernbohrer bis Ø 60 mm möglich.
Anzahl der Auswerferstifte nach Wunsch. Gerne stellen wir auch Ihr Wunschset zusammen.
Empty for max. 44 annular cutters. Maximum possible Ø 60 mm. Quantity ejector pins on request. We also compile your desired set on request.

GOLD-DRILL LINE / 55

SETS / DISPLAYS: INHALT 20 1270U
SETS / DISPLAYS: CONTENT 20 1270U

**BEST
SELLER**

Lagerprogramm + Zubehör siehe Seite 424-425
Stock range + accessories see page 424-425

6 Stück Pieces

SET BASIC • 20 1972



Ø 2×14, 2×18, 2×22 mm
2× Auswerferstifte / Ejector pins
Die meistverkauften drei Abmessungen in einem Set
The best selling three dimensions in a set

SET BASIC PLUS • 20 1332



Ø 12, 14, 16, 18, 20, 22 mm
2× Auswerferstifte / Ejector pins
Die BESTSELLER bis Ø 22 mm
BESTSELLER up to Ø 22 mm

SET INDIVIDUAL • 20 1138



Leer für max. 6 Kernbohrer + 4 Auswerferstifte.
Max. Ø 40 mm möglich. Gerne stellen wir auch Ihr Wunschset zusammen.
Empty for max. 6 annular cutters + 4 ejector pins.
Maximum possible Ø 40 mm. We also compile your desired set on request.

12 Stück Pieces

SET PROFI • 20 1973



Ø 4×14, 4×18, 4×22 mm
2× Auswerferstifte / Ejector pins
Die meistverkauften drei Abmessungen in einem Set
The best selling three dimensions in a set

SET PROFI PLUS • 20 1974



Ø 2×12, 2×14, 2×16, 2×18, 2×20, 2×22 mm
2× Auswerferstifte / Ejector pins
Die BESTSELLER bis Ø 22 mm
BESTSELLER up to Ø 22 mm

SET PROFI INDIVIDUAL • 20 1132



Leer für max. 12 Kernbohrer + 4 Auswerferstifte.
Max. Ø 40 mm möglich. Gerne stellen wir auch Ihr Wunschset zusammen.
Empty for max. 12 annular cutters + 4 ejector pins.
Maximum possible Ø 40 mm. We also compile your desired set on request.

≤ 50 Stück Pieces

SET DELUXE • 20 1365



Das komplette Sortiment 12-50 mm in 1,0 mm aufsteigend (39 Stück)
The hole range 12-50 mm in 1,0 mm steps (39 pieces)
6× Auswerferstifte / Ejector pins

SET DELUXE PLUS • 20 1980



Ø 4×12, 2×13, 4×14, 2×15, 4×16, 2×17, 4×18, 2×19, 4×20, 4×22, 2×23, 2×24, 2×25, 4×26, 2×27, 2×28, 2×30, 2×32 mm
6× Auswerferstifte / Ejector pins
Die BESTSELLER bis Ø 32 mm
BESTSELLER up to Ø 32 mm

SET DELUXE INDIVIDUAL • 20 1139



Leer für max. 50 Kernbohrer bis Ø 120 mm möglich.
Anzahl der Auswerferstifte nach Wunsch. Gerne stellen wir auch Ihr Wunschset zusammen.
Empty for max. 50 annular cutters. Maximum possible Ø 120 mm. Quantity ejector pins on request. We also compile your desired set on request.

44 Stück Pieces

Abschließbares Acryldisplay
Ideal als Showcase und Mini-Lager. Alle gängigen Abmessungen sofort sichtbar und griffbereit.

Lockable acrylic display
Ideal as showcase and small warehouse. All current sizes directly visible and available.

DISPLAY • 20 1608



Ø 2×12, 2×13, 2×14, 2×15, 2×16, 2×17, 2×18, 2×19, 2×20, 2×21, 2×22, 2×23, 2×24, 2×25, 2×26, 2×27, 2×28, 2×30, 2×32, 1×33, 1×35, 1×36, 1×40, 1×45, 1×50 mm
6× Auswerferstifte / Ejector pins
Die BESTSELLER bis Ø 50 mm
BESTSELLER up to Ø 50 mm

DISPLAY INDIVIDUAL • 20 1344



Leer für max. 44 Kernbohrer bis Ø 60 mm möglich.
Anzahl der Auswerferstifte nach Wunsch. Gerne stellen wir auch Ihr Wunschset zusammen.
Empty for max. 44 annular cutters. Maximum possible Ø 60 mm. Quantity ejector pins on request. We also compile your desired set on request.

- 1 
- 2 
- 3 
- 4 
- 5 
- 6 
- 7 
- 8 
- 9 
- 10 

GOLD-DRILL LINE 30
ZOLL / INCH

SETS / DISPLAYS: INHALT 20 1910
SETS / DISPLAYS: CONTENT 20 1910

Lagerprogramm + Zubehör siehe Seite 430-431
Stock range + accessories see page 430-431

1



2



3



4



5



6



7



8



9



10



6 Stück Pieces

SET BASIC • 20 1993

Ø 2× 5/8", 2× 13/16", 2× 9/16"
2× Auswerferstifte / Ejector pins
Die meistverkauften drei Abmessungen in einem Set
The best selling three dimensions in a set

SET BASIC PLUS • 20 1976

Ø 9/16", 5/8", 11/16, 3/4", 13/16", 7/8"
2× Auswerferstifte / Ejector pins
Die BESTSELLER bis Ø 7/8"
BESTSELLER up to Ø 7/8"

SET INDIVIDUAL • 20 1138

Leer für max. 6 Kernbohrer + 4 Auswerferstifte.
Max. Ø 40 mm möglich. Gerne stellen wir auch Ihr Wunschset zusammen.
Empty for max. 6 annular cutters + 4 ejector pins.
Maximum possible Ø 40 mm. We also compile your desired set on request.

12 Stück Pieces

SET PROFI • 20 1994

Ø 4× 5/8", 4× 13/16", 4× 9/16"
2× Auswerferstifte / Ejector pins
Die meistverkauften drei Abmessungen in einem Set
The best selling three dimensions in a set

SET PROFI PLUS • 20 1995

Ø 2× 9/16", 2× 5/8", 2× 11/16, 2× 3/4", 2× 13/16", 2× 7/8"
2× Auswerferstifte / Ejector pins
Die BESTSELLER bis Ø 7/8"
BESTSELLER up to Ø 7/8"

SET PROFI INDIVIDUAL • 20 1132

Leer für max. 12 Kernbohrer + 4 Auswerferstifte.
Max. Ø 40 mm möglich. Gerne stellen wir auch Ihr Wunschset zusammen.
Empty for max. 12 annular cutters + 4 ejector pins.
Maximum possible Ø 40 mm. We also compile your desired set on request.

≤ 50 Stück Pieces

SET DELUXE INDIVIDUAL • 20 1139

Leer für max. 50 Kernbohrer bis Ø 120 mm möglich.
Anzahl der Auswerferstifte nach Wunsch. Gerne stellen wir auch Ihr Wunschset zusammen.
Empty for max. 50 annular cutters. Maximum possible Ø 120 mm. Quantity ejector pins on request. We also compile your desired set on request.

44 Stück Pieces

Abschließbares Acryldisplay
Ideal als Showcase und Mini-Lager. Alle gängigen Abmessungen sofort sichtbar und griffbereit.

Lockable acrylic display
Ideal as showcase and small warehouse. All current sizes directly visible and available.

DISPLAY INDIVIDUAL • 20 1344

Leer für max. 44 Kernbohrer bis Ø 60 mm möglich.
Anzahl der Auswerferstifte nach Wunsch. Gerne stellen wir auch Ihr Wunschset zusammen.
Empty for max. 44 annular cutters. Maximum possible Ø 60 mm. Quantity ejector pins on request. We also compile your desired set on request.

GOLD-DRILL LINE 55
ZOLL / INCH

SETS / DISPLAYS: INHALT 20 1920
SETS / DISPLAYS: CONTENT 20 1920

Lagerprogramm + Zubehör siehe Seite 432-433
Stock range + accessories see page 432-433

6
Stück
Pieces

SET BASIC • 20 1996

Ø 2× 5/8", 2× 11/16", 2× 13/16"
2× Auswerferstifte / Ejector pins
Die meistverkauften drei Abmessungen in einem Set
The best selling three dimensions in a set

SET BASIC PLUS • 20 1977

Ø 9/16", 5/8", 11/16", 3/4", 13/16", 7/8"
2× Auswerferstifte / Ejector pins
Die BESTSELLER bis Ø 7/8"
BESTSELLER up to Ø 7/8"

SET INDIVIDUAL • 20 1138

Leer für max. 6 Kernbohrer + 4 Auswerferstifte.
Max. Ø 40 mm möglich. Gerne stellen wir auch Ihr Wunschset zusammen.
Empty for max. 6 annular cutters + 4 ejector pins.
Maximum possible Ø 40 mm. We also compile your desired set on request.

12
Stück
Pieces

SET PROFI • 20 1997

Ø 3× 5/8", 3× 11/16", 3× 13/16", 3× 7/8"
2× Auswerferstifte / Ejector pins
Die meistverkauften vier Abmessungen in einem Set
The best selling four dimensions in a set

SET PROFI PLUS • 20 1998

Ø 2× 9/16", 2× 5/8", 2× 11/16", 2× 3/4", 2× 13/16", 2× 7/8"
2× Auswerferstifte / Ejector pins
Die BESTSELLER bis Ø 7/8"
BESTSELLER up to Ø 7/8"

SET PROFI INDIVIDUAL • 20 1132

Leer für max. 12 Kernbohrer + 4 Auswerferstifte.
Max. Ø 40 mm möglich. Gerne stellen wir auch Ihr Wunschset zusammen.
Empty for max. 12 annular cutters + 4 ejector pins.
Maximum possible Ø 40 mm. We also compile your desired set on request.

≤ 50
Stück
Pieces

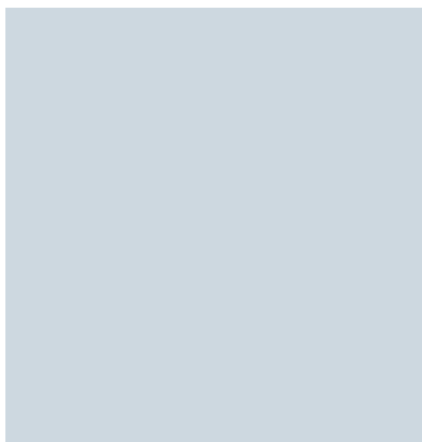
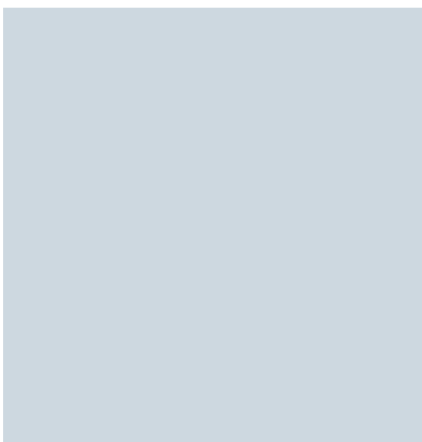

SET DELUXE INDIVIDUAL • 20 1139

Leer für max. 50 Kernbohrer bis Ø 120 mm möglich.
Anzahl der Auswerferstifte nach Wunsch. Gerne stellen wir auch Ihr Wunschset zusammen.
Empty for max. 50 annular cutters. Maximum possible Ø 120 mm. Quantity ejector pins on request. We also compile your desired set on request.

44
Stück
Pieces

Abschließbares Acryldisplay
Ideal als Showcase und Mini-Lager. Alle gängigen Abmessungen sofort sichtbar und griffbereit.

Lockable acrylic display
Ideal as showcase and small warehouse. All current sizes directly visible and available.

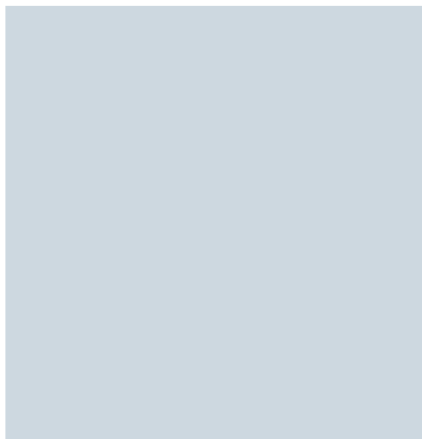

DISPLAY INDIVIDUAL • 20 1344

Leer für max. 44 Kernbohrer bis Ø 60 mm möglich.
Anzahl der Auswerferstifte nach Wunsch. Gerne stellen wir auch Ihr Wunschset zusammen.
Empty for max. 44 annular cutters. Maximum possible Ø 60 mm. Quantity ejector pins on request. We also compile your desired set on request.

- 1
- 2
- 3
- 4
- 5
- 6
- 7
- 8
- 9
- 10



SILVER-DRILL LINE 25

SETS / DISPLAYS: INHALT 20 1255
SETS / DISPLAYS: CONTENT 20 1255

BEST
SELLER

Lagerprogramm + Zubehör siehe Seite 438-439
Stock range + accessories see page 438-439

- 1
- 2
- 3
- 4
- 5
- 6
- 7
- 8
- 9
- 10

<p>6 Stück Pieces</p>	<p>SET BASIC</p> 	<p>• 20 2003</p> 	<p>SET BASIC PLUS</p> 	<p>• 20 1474</p> 	<p>SET INDIVIDUAL</p> 	<p>• 20 1138</p> 								
	<p>Ø 2x14, 2x18, 2x22 mm 2x Auswerferstifte / Ejector pins Die meistverkauften drei Abmessungen in einem Set The best selling three dimensions in a set</p>	<p>Ø 12, 14, 16, 18, 20, 22 mm 2x Auswerferstifte / Ejector pins Die BESTSELLER bis Ø 22 mm BESTSELLER up to Ø 22 mm</p>	<p>Leer für max. 6 Kernbohrer + 4 Auswerferstifte. Max. Ø 40 mm möglich. Gerne stellen wir auch Ihr Wunschset zusammen. Empty for max. 6 annular cutters + 4 ejector pins. Maximum possible Ø 40 mm. We also compile your desired set on request.</p>											
	<p>12 Stück Pieces</p>			<p>SET PROFI</p> 			<p>• 20 2004</p> 	<p>SET PROFI PLUS</p> 			<p>• 20 2005</p> 	<p>SET PROFI INDIVIDUAL</p> 		
<p>Ø 3x12, 3x14, 3x18, 3x22 mm 2x Auswerferstifte / Ejector pins Die meistverkauften vier Abmessungen in einem Set The best selling four dimensions in a set</p>	<p>Ø 2x12, 2x14, 2x16, 2x18, 2x20, 2x22 mm 2x Auswerferstifte / Ejector pins Die BESTSELLER bis Ø 22 mm BESTSELLER up to Ø 22 mm</p>	<p>Leer für max. 12 Kernbohrer + 4 Auswerferstifte. Max. Ø 40 mm möglich. Gerne stellen wir auch Ihr Wunschset zusammen. Empty for max. 12 annular cutters + 4 ejector pins. Maximum possible Ø 40 mm. We also compile your desired set on request.</p>												
<p>≤ 50 Stück Pieces</p>			<p>SET DELUXE</p> 			<p>• 20 1153</p> 	<p>SET DELUXE PLUS</p> 			<p>• 20 2006</p> 	<p>SET DELUXE INDIVIDUAL</p> 			<p>• 20 1139</p> 
<p>Das komplette Sortiment 12-50 mm in 1,0 mm aufsteigend (39 Stück) The hole range 12-50 mm in 1,0 mm steps (39 pieces) 6x Auswerferstifte / Ejector pins</p>	<p>Ø 4x12, 2x13, 4x14, 2x15, 4x16, 2x17, 4x18, 2x19, 4x20, 4x22, 2x23, 2x24, 2x25, 4x26, 2x27, 2x28, 2x30, 2x32 mm 6x Auswerferstifte / Ejector pins Die BESTSELLER bis Ø 32 mm BESTSELLER up to Ø 32 mm</p>	<p>Leer für max. 50 Kernbohrer bis Ø 120 mm möglich. Anzahl der Auswerferstifte nach Wunsch. Gerne stellen wir auch Ihr Wunschset zusammen. Empty for max. 50 annular cutters. Maximum possible Ø 120 mm. Quantity ejector pins on request. We also compile your desired set on request.</p>												
<p>44 Stück Pieces</p>			<p>ABSCHLIEßBARES ACRYLDISPLAY Ideal als Showcase und Mini-Lager. Alle gängigen Abmessungen sofort sichtbar und griffbereit. Lockable acrylic display Ideal as showcase and small warehouse. All current sizes directly visible and available.</p>			<p>DISPLAY</p> 			<p>• 20 1158</p> 	<p>DISPLAY INDIVIDUAL</p> 			<p>• 20 1344</p> 	
<p>Die BESTSELLER bis Ø 50 mm BESTSELLER up to Ø 50 mm</p>	<p>Ø 2x12, 2x13, 2x14, 2x15, 2x16, 2x17, 2x18, 2x19, 2x20, 2x21, 2x22, 2x23, 2x24, 2x25, 2x26, 2x27, 2x28, 2x30, 2x32, 1x33, 1x35, 1x36, 1x40, 1x45, 1x50 mm 6x Auswerferstifte / Ejector pins Die BESTSELLER bis Ø 50 mm BESTSELLER up to Ø 50 mm</p>	<p>Leer für max. 44 Kernbohrer bis Ø 60 mm möglich. Anzahl der Auswerferstifte nach Wunsch. Gerne stellen wir auch Ihr Wunschset zusammen. Empty for max. 44 annular cutters. Maximum possible Ø 60 mm. Quantity ejector pins on request. We also compile your desired set on request.</p>												

SILVER-DRILL LINE / 50

SETS / DISPLAYS: INHALT 20 1265
SETS / DISPLAYS: CONTENT 20 1265

**BEST
SELLER**

Lagerprogramm + Zubehör siehe Seite 440-441
Stock range + accessories see page 440-441

6
Stück
Pieces

SET BASIC • 20 2007

Ø 2×14, 2×18, 2×22 mm
2× Auswerferstifte / Ejector pins
Die meistverkauften drei Abmessungen in einem Set
The best selling three dimensions in a set

SET BASIC PLUS • 20 1475

Ø 14, 16, 18, 20, 22, 26 mm
2× Auswerferstifte / Ejector pins
Die BESTSELLER bis Ø 26 mm
BESTSELLER up to Ø 26 mm

SET INDIVIDUAL • 20 1138

Leer für max. 6 Kernbohrer + 4 Auswerferstifte.
Max. Ø 40 mm möglich. Gerne stellen wir auch Ihr Wunschset zusammen.
Empty for max. 6 annular cutters + 4 ejector pins.
Maximum possible Ø 40 mm. We also compile your desired set on request.

12
Stück
Pieces

SET PROFI • 20 2008

Ø 4×14, 4×18, 4×22 mm
2× Auswerferstifte / Ejector pins
Die meistverkauften drei Abmessungen in einem Set
The best selling three dimensions in a set

SET PROFI PLUS • 20 2009

Ø 2×14, 2×16, 2×18, 2×20, 2×22, 2×26 mm
2× Auswerferstifte / Ejector pins
Die BESTSELLER bis Ø 26 mm
BESTSELLER up to Ø 26 mm

SET PROFI INDIVIDUAL • 20 1132

Leer für max. 12 Kernbohrer + 4 Auswerferstifte.
Max. Ø 40 mm möglich. Gerne stellen wir auch Ihr Wunschset zusammen.
Empty for max. 12 annular cutters + 4 ejector pins.
Maximum possible Ø 40 mm. We also compile your desired set on request.

≤ 50
Stück
Pieces

SET DELUXE • 20 1483

Das komplette Sortiment 12-50 mm in 1,0 mm aufsteigend (39 Stück)
The hole range 12-50 mm in 1,0 mm steps (39 pieces)
6× Auswerferstifte / Ejector pins

SET DELUXE PLUS • 20 2010

Ø 4×12, 2×13, 4×14, 2×15, 4×16, 2×17, 4×18, 2×19, 4×20, 2×21, 4×22, 2×24, 2×25, 4×26, 2×27, 2×28, 2×30, 2×32 mm
6× Auswerferstifte / Ejector pins
Die BESTSELLER bis Ø 32 mm
BESTSELLER up to Ø 32 mm

SET DELUXE INDIVIDUAL • 20 1139

Leer für max. 50 Kernbohrer bis Ø 120 mm möglich.
Anzahl der Auswerferstifte nach Wunsch. Gerne stellen wir auch Ihr Wunschset zusammen.
Empty for max. 50 annular cutters. Maximum possible Ø 120 mm. Quantity ejector pins on request. We also compile your desired set on request.

44
Stück
Pieces

Abschließbares Acryldisplay
Ideal als Showcase und Mini-Lager. Alle gängigen Abmessungen sofort sichtbar und griffbereit.

Lockable acrylic display
Ideal as showcase and small warehouse. All current sizes directly visible and available.

DISPLAY • 20 1607

Ø 2×12, 2×13, 2×14, 2×15, 2×16, 2×17, 2×18, 2×19, 2×20, 2×21, 2×22, 2×23, 2×24, 2×25, 2×26, 2×27, 2×28, 2×30, 2×32, 1×33, 1×35, 1×36, 1×40, 1×45, 1×50 mm
6× Auswerferstifte / Ejector pins
Die BESTSELLER bis Ø 50 mm
BESTSELLER up to Ø 50 mm

DISPLAY INDIVIDUAL • 20 1344

Leer für max. 44 Kernbohrer bis Ø 60 mm möglich.
Anzahl der Auswerferstifte nach Wunsch. Gerne stellen wir auch Ihr Wunschset zusammen.
Empty for max. 44 annular cutters. Maximum possible Ø 60 mm. Quantity ejector pins on request. We also compile your desired set on request.

- 1
- 2
- 3
- 4
- 5
- 6
- 7
- 8
- 9
- 10

HARD-LINE 40 SETS / DISPLAYS: INHALT 20 1315N
SETS / DISPLAYS: CONTENT 20 1315N

Lagerprogramm + Zubehör siehe Seite 454-455
Stock range + accessories see page 454-455

- 1
- 2
- 3
- 4
- 5
- 6
- 7
- 8
- 9
- 10

6 Stück Pieces

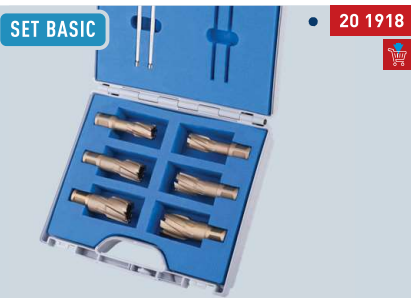

SET BASIC • 20 1918

Ø 2×18, 2×22, 2×26 mm
2× Auswerferstifte / Ejector pins
Die meistverkauften drei Abmessungen in einem Set
The best selling three dimensions in a set



SET BASIC PLUS • 20 1329

Ø 12, 14, 16, 18, 22, 26 mm
4× Auswerferstifte / Ejector pins
Die BESTSELLER bis Ø 26 mm
BESTSELLER up to Ø 26 mm

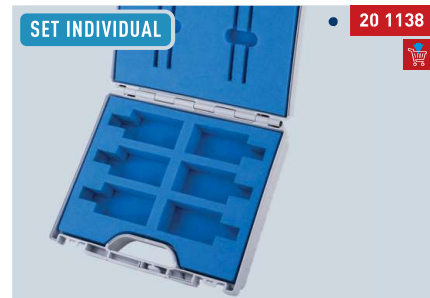

SET INDIVIDUAL • 20 1138

Leer für max. 6 Kernbohrer + 4 Auswerferstifte.
Max. Ø 40 mm möglich. Gerne stellen wir auch Ihr Wunschset zusammen.
Empty for max. 6 annular cutters + 4 ejector pins.
Maximum possible Ø 40 mm. We also compile your desired set on request.

12 Stück Pieces

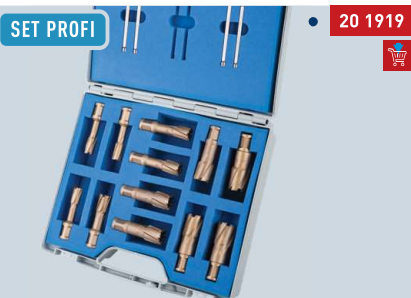

SET PROFI • 20 1919

Ø 3×14, 3×18, 3×22, 3×26 mm
4× Auswerferstifte / Ejector pins
Die meistverkauften vier Abmessungen in einem Set
The best selling four dimensions in a set



SET PROFI PLUS • 20 1921

Ø 2×12, 2×14, 2×16, 2×18, 2×22, 2×26 mm
4× Auswerferstifte / Ejector pins
Die BESTSELLER bis Ø 26 mm
BESTSELLER up to Ø 26 mm

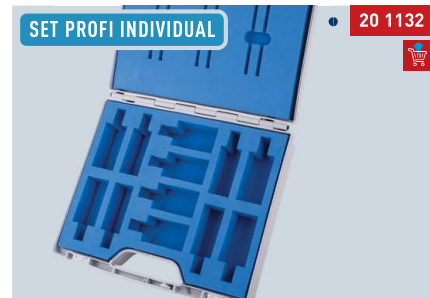

SET PROFI INDIVIDUAL • 20 1132

Leer für max. 12 Kernbohrer + 4 Auswerferstifte.
Max. Ø 40 mm möglich. Gerne stellen wir auch Ihr Wunschset zusammen.
Empty for max. 12 annular cutters + 4 ejector pins.
Maximum possible Ø 40 mm. We also compile your desired set on request.

≤ 50 Stück Pieces

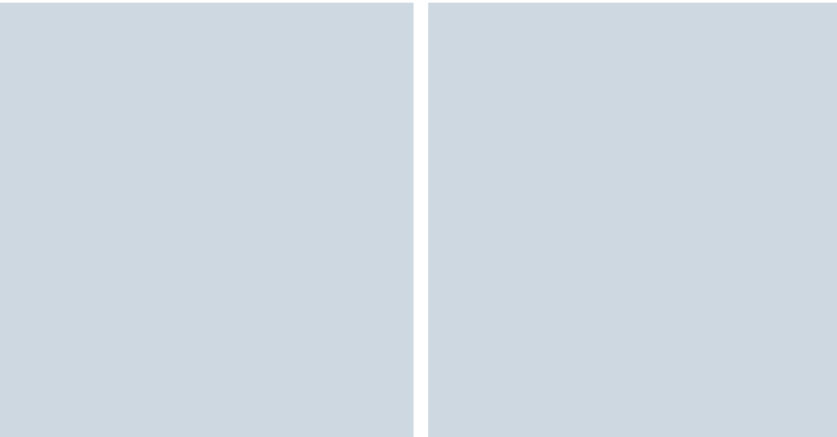

SET DELUXE INDIVIDUAL • 20 1139

Leer für max. 50 Kernbohrer bis Ø 120 mm möglich.
Anzahl der Auswerferstifte nach Wunsch. Gerne stellen wir auch Ihr Wunschset zusammen.
Empty for max. 50 annular cutters. Maximum possible Ø 120 mm. Quantity ejector pins on request. We also compile your desired set on request.

44 Stück Pieces

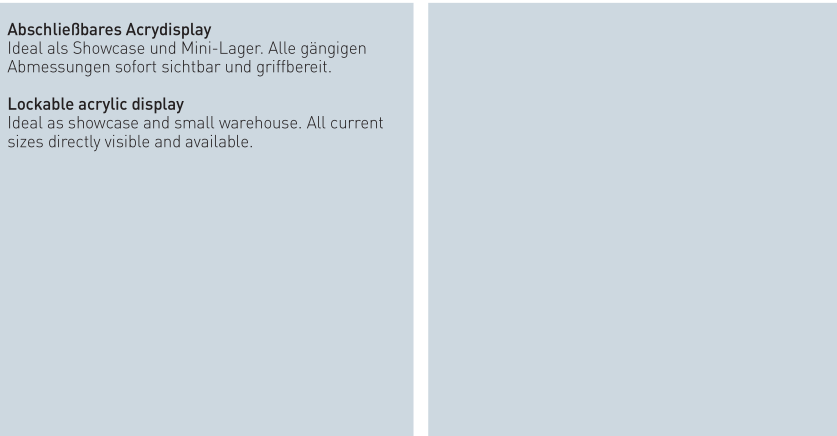

Abschließbares Acrydisplay
Ideal als Showcase und Mini-Lager. Alle gängigen Abmessungen sofort sichtbar und griffbereit.
Lockable acrylic display
Ideal as showcase and small warehouse. All current sizes directly visible and available.



DISPLAY INDIVIDUAL • 20 1344

Leer für max. 44 Kernbohrer bis Ø 60 mm möglich.
Anzahl der Auswerferstifte nach Wunsch. Gerne stellen wir auch Ihr Wunschset zusammen.
Empty for max. 44 annular cutters. Maximum possible Ø 60 mm. Quantity ejector pins on request. We also compile your desired set on request.

HARD-LINE 55

SETS / DISPLAYS: INHALT 20 1316N
SETS / DISPLAYS: CONTENT 20 1316N

Lagerprogramm + Zubehör siehe Seite 456-457
Stock range + accessories see page 456-457

6
Stück
Pieces

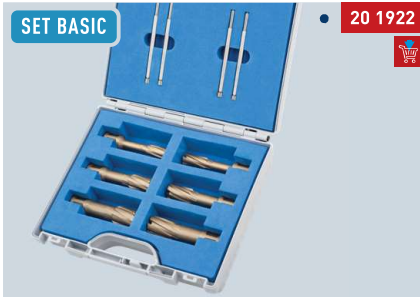

• 20 1922

Ø 2x14, 2x18, 2x22 mm
4x Auswerferstifte / Ejector pins
Die meistverkauften drei Abmessungen in einem Set
The best selling three dimensions in a set



• 20 1338

Ø 12, 14, 16, 18, 22, 26 mm
4x Auswerferstifte / Ejector pins
Die BESTSELLER bis Ø 26 mm
BESTSELLER up to Ø 26 mm

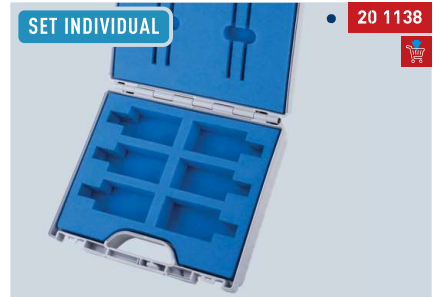

• 20 1138

Leer für max. 6 Kernbohrer + 4 Auswerferstifte.
Max. Ø 40 mm möglich. Gerne stellen wir auch Ihr Wunschset zusammen.
Empty for max. 6 annular cutters + 4 ejector pins.
Maximum possible Ø 40 mm. We also compile your desired set on request.

12
Stück
Pieces



• 20 1923

Ø 3x14, 3x18, 3x22, 3x26 mm
4x Auswerferstifte / Ejector pins
Die meistverkauften vier Abmessungen in einem Set
The best selling four dimensions in a set



• 20 1924

Ø 2x14, 2x16, 2x18, 2x20, 2x22, 2x26 mm
4x Auswerferstifte / Ejector pins
Die BESTSELLER bis Ø 26 mm
BESTSELLER up to Ø 26 mm



• 20 1132

Leer für max. 12 Kernbohrer + 4 Auswerferstifte.
Max. Ø 40 mm möglich. Gerne stellen wir auch Ihr Wunschset zusammen.
Empty for max. 12 annular cutters + 4 ejector pins.
Maximum possible Ø 40 mm. We also compile your desired set on request.

≤ 50
Stück
Pieces

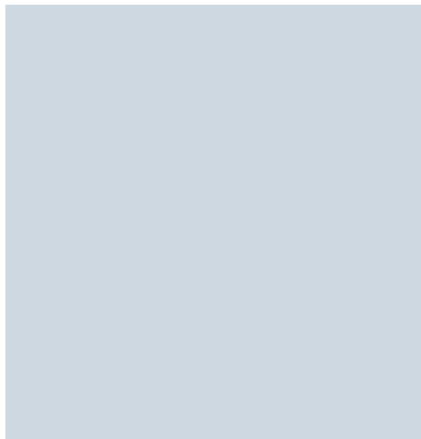
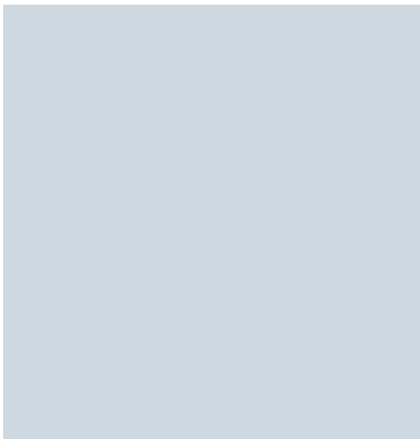

• 20 1139

Leer für max. 50 Kernbohrer bis Ø 120 mm möglich.
Anzahl der Auswerferstifte nach Wunsch. Gerne stellen wir auch Ihr Wunschset zusammen.
Empty for max. 50 annular cutters. Maximum possible Ø 120 mm. Quantity ejector pins on request. We also compile your desired set on request.

44
Stück
Pieces

Abschließbares Acryldisplay
Ideal als Showcase und Mini-Lager. Alle gängigen Abmessungen sofort sichtbar und griffbereit.

Lockable acrylic display
Ideal as showcase and small warehouse. All current sizes directly visible and available.

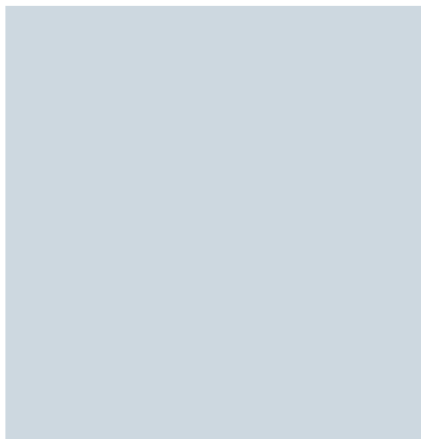

• 20 1344

Leer für max. 44 Kernbohrer bis Ø 60 mm möglich.
Anzahl der Auswerferstifte nach Wunsch. Gerne stellen wir auch Ihr Wunschset zusammen.
Empty for max. 44 annular cutters. Maximum possible Ø 60 mm. Quantity ejector pins on request. We also compile your desired set on request.

- 1
- 2
- 3
- 4
- 5
- 6
- 7
- 8
- 9
- 10

HARD-LINE
ZOLL / INCH

40

SETS / DISPLAYS: INHALT 20 1630
SETS / DISPLAYS: CONTENT 20 1630

Lagerprogramm + Zubehör siehe Seite 462-463
Stock range + accessories see page 462-463

- 1 
- 2 
- 3 
- 4 
- 5 
- 6 
- 7 
- 8 
- 9 
- 10 

6 Stück Pieces

SET BASIC • 20 1926 





Ø 2× 5/8", 2× 13/16", 2× 15/16"
2× Auswerferstifte / Ejector pins
Die meistverkauften drei Abmessungen in einem Set
The best selling three dimensions in a set

SET BASIC PLUS • 20 1478 



Ø 9/16", 5/8", 3/4", 13/16", 15/16", 1.1/16"
2× Auswerferstifte / Ejector pins
Die BESTSELLER bis Ø 1.1/16"
BESTSELLER up to Ø 1.1/16"

SET INDIVIDUAL • 20 1138 



Leer für max. 6 Kernbohrer + 4 Auswerferstifte.
Max. Ø 40 mm möglich. Gerne stellen wir auch Ihr Wunschset zusammen.
Empty for max. 6 annular cutters + 4 ejector pins.
Maximum possible Ø 40 mm. We also compile your desired set on request.

12 Stück Pieces

SET PROFI • 20 1927 



Ø 4× 5/8", 4× 13/16", 4× 15/16"
2× Auswerferstifte / Ejector pins
Die meistverkauften drei Abmessungen in einem Set
The best selling three dimensions in a set

SET PROFI PLUS • 20 1928 



Ø 2× 9/16", 2× 5/8", 2× 3/4", 2× 13/16",
2× 15/16", 2× 1.1/16"
2× Auswerferstifte / Ejector pins
Die BESTSELLER bis Ø 1.1/16"
BESTSELLER up to Ø 1.1/16"

SET PROFI INDIVIDUAL • 20 1132 



Leer für max. 12 Kernbohrer + 4 Auswerferstifte.
Max. Ø 40 mm möglich. Gerne stellen wir auch Ihr Wunschset zusammen.
Empty for max. 12 annular cutters + 4 ejector pins.
Maximum possible Ø 40 mm. We also compile your desired set on request.

≤ 50 Stück Pieces

Empty display area for sets with ≤ 50 pieces.

SET DELUXE INDIVIDUAL • 20 1139 



Leer für max. 50 Kernbohrer bis Ø 120 mm möglich.
Anzahl der Auswerferstifte nach Wunsch. Gerne stellen wir auch Ihr Wunschset zusammen.
Empty for max. 50 annular cutters. Maximum possible Ø 120 mm. Quantity ejector pins on request. We also compile your desired set on request.

44 Stück Pieces

Abschließbares Acryldisplay
Ideal als Showcase und Mini-Lager. Alle gängigen Abmessungen sofort sichtbar und griffbereit.

Lockable acrylic display
Ideal as showcase and small warehouse. All current sizes directly visible and available.

DISPLAY INDIVIDUAL • 20 1344 



Leer für max. 44 Kernbohrer bis Ø 60 mm möglich.
Anzahl der Auswerferstifte nach Wunsch. Gerne stellen wir auch Ihr Wunschset zusammen.
Empty for max. 44 annular cutters. Maximum possible Ø 60 mm. Quantity ejector pins on request. We also compile your desired set on request.

HARD-LINE
ZOLL / INCH **55**

SETS / DISPLAYS: INHALT 20 1640
SETS / DISPLAYS: CONTENT 20 1640

Lagerprogramm + Zubehör siehe Seite 464-465
Stock range + accessories see page 464-465

6
Stück
Pieces

SET BASIC • 20 1929

Ø 2× 13/16", 2× 15/16", 2× 1.1/16"
2× Auswerferstifte / Ejector pins
Die meistverkauften drei Abmessungen in einem Set
The best selling three dimensions in a set

SET BASIC PLUS • 20 1479

Ø 5/8", 11/16", 3/4", 13/16", 15/16", 1.1/16"
2× Auswerferstifte / Ejector pins
Die BESTSELLER bis Ø 1.1/16"
BESTSELLER up to Ø 1.1/16"

SET INDIVIDUAL • 20 1138

Leer für max. 6 Kernbohrer + 4 Auswerferstifte.
Max. Ø 40 mm möglich. Gerne stellen wir auch Ihr Wunschset zusammen.
Empty for max. 6 annular cutters + 4 ejector pins.
Maximum possible Ø 40 mm. We also compile your desired set on request.

12
Stück
Pieces

SET PROFI • 20 1931

Ø 4× 13/16", 4× 15/16", 4× 1.1/16"
2× Auswerferstifte / Ejector pins
Die meistverkauften drei Abmessungen in einem Set
The best selling three dimensions in a set

SET PROFI PLUS • 20 1932

Ø 2× 5/8", 2× 11/16", 2× 3/4", 2× 13/16", 2× 15/16",
2× 1.1/16"
2× Auswerferstifte / Ejector pins
Die BESTSELLER bis Ø 1.1/16"
BESTSELLER up to Ø 1.1/16"

SET PROFI INDIVIDUAL • 20 1132

Leer für max. 12 Kernbohrer + 4 Auswerferstifte.
Max. Ø 40 mm möglich. Gerne stellen wir auch Ihr Wunschset zusammen.
Empty for max. 12 annular cutters + 4 ejector pins.
Maximum possible Ø 40 mm. We also compile your desired set on request.

≤ 50
Stück
Pieces

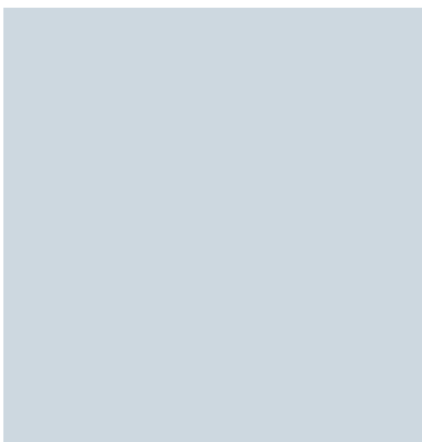
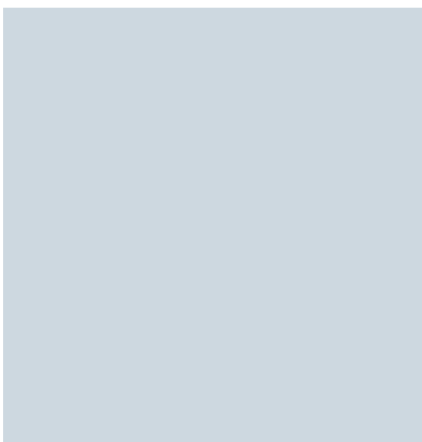

SET DELUXE INDIVIDUAL • 20 1139

Leer für max. 50 Kernbohrer bis Ø 120 mm möglich.
Anzahl der Auswerferstifte nach Wunsch. Gerne stellen wir auch Ihr Wunschset zusammen.
Empty for max. 50 annular cutters. Maximum possible Ø 120 mm. Quantity ejector pins on request. We also compile your desired set on request.

44
Stück
Pieces

Abschließbares Acryldisplay
Ideal als Showcase und Mini-Lager. Alle gängigen Abmessungen sofort sichtbar und griffbereit.

Lockable acrylic display
Ideal as showcase and small warehouse. All current sizes directly visible and available.

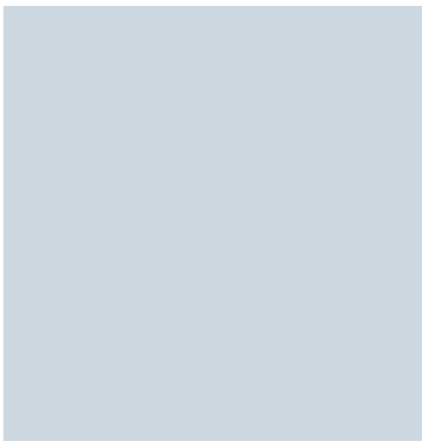

DISPLAY INDIVIDUAL • 20 1344

Leer für max. 44 Kernbohrer bis Ø 60 mm möglich.
Anzahl der Auswerferstifte nach Wunsch. Gerne stellen wir auch Ihr Wunschset zusammen.
Empty for max. 44 annular cutters. Maximum possible Ø 60 mm. Quantity ejector pins on request. We also compile your desired set on request.

- 1
- 2
- 3
- 4
- 5
- 6
- 7
- 8
- 9
- 10

BLUE-DRILL LINE 30 SETS / DISPLAYS: INHALT 20 1312N
SETS / DISPLAYS: CONTENT 20 1312N

- 1
- 2
- 3
- 4
- 5
- 6
- 7
- 8
- 9
- 10

<p>6 Stück Pieces</p>	<p>SET BASIC • 20 1958 </p> <p>Ø 2×16, 2×18, 2×22 mm 2× Auswerferstifte / Ejector pins Die meistverkauften drei Abmessungen in einem Set The best selling three dimensions in a set</p>	<p>SET BASIC PLUS • 20 1348 </p> <p>Ø 14, 16, 18, 20, 22, 26 mm 2× Auswerferstifte / Ejector pins Die BESTSELLER bis Ø 26 mm BESTSELLER up to Ø 26 mm</p>	<p>SET INDIVIDUAL • 20 1138 </p> <p>Leer für max. 6 Kernbohrer + 4 Auswerferstifte. Max. Ø 40 mm möglich. Gerne stellen wir auch Ihr Wunschset zusammen. Empty for max. 6 annular cutters + 4 ejector pins. Maximum possible Ø 40 mm. We also compile your desired set on request.</p>
<p>12 Stück Pieces</p>	<p>SET PROFI • 20 1959 </p> <p>Ø 3×14, 3×18, 3×20, 3×22 mm 2× Auswerferstifte / Ejector pins Die meistverkauften vier Abmessungen in einem Set The best selling four dimensions in a set</p>	<p>SET PROFI PLUS • 20 1960 </p> <p>Ø 2×14, 2×16, 2×18, 2×20, 2×22, 2×26 mm 2× Auswerferstifte / Ejector pins Die BESTSELLER bis Ø 26 mm BESTSELLER up to Ø 26 mm</p>	<p>SET PROFI INDIVIDUAL • 20 1132 </p> <p>Leer für max. 12 Kernbohrer + 4 Auswerferstifte. Max. Ø 40 mm möglich. Gerne stellen wir auch Ihr Wunschset zusammen. Empty for max. 12 annular cutters + 4 ejector pins. Maximum possible Ø 40 mm. We also compile your desired set on request.</p>
<p>≤ 50 Stück Pieces</p>			<p>SET DELUXE INDIVIDUAL • 20 1139 </p> <p>Leer für max. 50 Kernbohrer bis Ø 120 mm möglich. Anzahl der Auswerferstifte nach Wunsch. Gerne stellen wir auch Ihr Wunschset zusammen. Empty for max. 50 annular cutters. Maximum possible Ø 120 mm. Quantity ejector pins on request. We also compile your desired set on request.</p>
<p>44 Stück Pieces</p>	<p>Abschließbares Acryldisplay Ideal als Showcase und Mini-Lager. Alle gängigen Abmessungen sofort sichtbar und griffbereit.</p> <p>Lockable acrylic display Ideal as showcase and small warehouse. All current sizes directly visible and available.</p>		<p>DISPLAY INDIVIDUAL • 20 1344 </p> <p>Leer für max. 44 Kernbohrer bis Ø 60 mm möglich. Anzahl der Auswerferstifte nach Wunsch. Gerne stellen wir auch Ihr Wunschset zusammen. Empty for max. 44 annular cutters. Maximum possible Ø 60 mm. Quantity ejector pins on request. We also compile your desired set on request.</p>

BLUE-DRILL LINE/55

SETS / DISPLAYS: INHALT 20 1313N
SETS / DISPLAYS: CONTENT 20 1313N

Lagerprogramm + Zubehör siehe Seite 472-473
Stock range + accessories see page 472-473

6
Stück
Pieces

SET BASIC • 20 1961

Ø 2×14, 2×18, 2×22 mm
2× Auswerferstifte / Ejector pins
Die meistverkauften drei Abmessungen in einem Set
The best selling three dimensions in a set

SET BASIC PLUS • 20 1349

Ø 14, 16, 18, 20, 22, 26 mm
2× Auswerferstifte / Ejector pins
Die BESTSELLER bis Ø 26 mm
BESTSELLER up to Ø 26 mm

SET INDIVIDUAL • 20 1138

Leer für max. 6 Kernbohrer + 4 Auswerferstifte.
Max. Ø 40 mm möglich. Gerne stellen wir auch Ihr Wunschset zusammen.
Empty for max. 6 annular cutters + 4 ejector pins.
Maximum possible Ø 40 mm. We also compile your desired set on request.

12
Stück
Pieces

SET PROFI • 20 1962

Ø 3×14, 3×18, 3×20, 3×22 mm
2× Auswerferstifte / Ejector pins
Die meistverkauften vier Abmessungen in einem Set
The best selling four dimensions in a set

SET PROFI PLUS • 20 1963

Ø 2×14, 2×16, 2×18, 2×20, 2×22, 2×26 mm
2× Auswerferstifte / Ejector pins
Die BESTSELLER bis Ø 26 mm
BESTSELLER up to Ø 26 mm

SET PROFI INDIVIDUAL • 20 1132

Leer für max. 12 Kernbohrer + 4 Auswerferstifte.
Max. Ø 40 mm möglich. Gerne stellen wir auch Ihr Wunschset zusammen.
Empty for max. 12 annular cutters + 4 ejector pins.
Maximum possible Ø 40 mm. We also compile your desired set on request.

≤ 50
Stück
Pieces

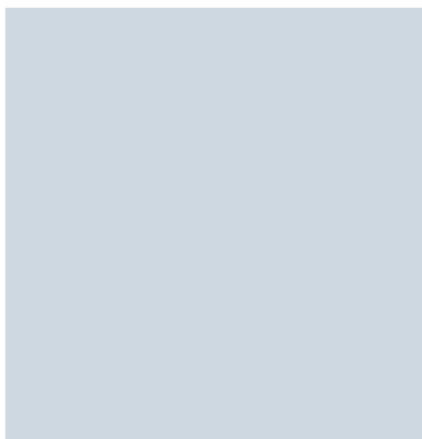
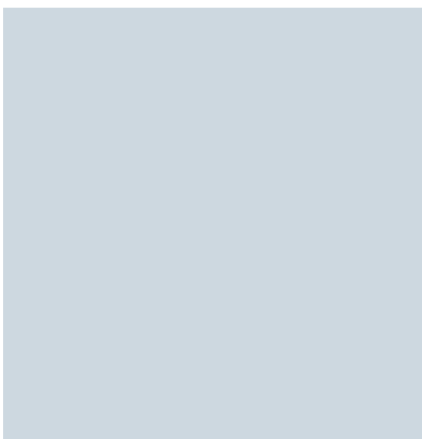

SET DELUXE INDIVIDUAL • 20 1139

Leer für max. 50 Kernbohrer bis Ø 120 mm möglich.
Anzahl der Auswerferstifte nach Wunsch. Gerne stellen wir auch Ihr Wunschset zusammen.
Empty for max. 50 annular cutters. Maximum possible Ø 120 mm. Quantity ejector pins on request. We also compile your desired set on request.

44
Stück
Pieces

Abschließbares Acryldisplay
Ideal als Showcase und Mini-Lager. Alle gängigen Abmessungen sofort sichtbar und griffbereit.

Lockable acrylic display
Ideal as showcase and small warehouse. All current sizes directly visible and available.

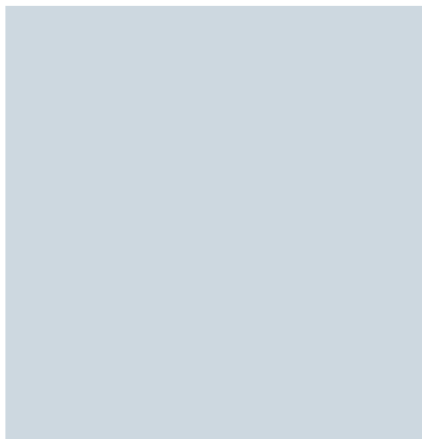

DISPLAY INDIVIDUAL • 20 1344

Leer für max. 44 Kernbohrer bis Ø 60 mm möglich.
Anzahl der Auswerferstifte nach Wunsch. Gerne stellen wir auch Ihr Wunschset zusammen.
Empty for max. 44 annular cutters. Maximum possible Ø 60 mm. Quantity ejector pins on request. We also compile your desired set on request.





- 1
- 2
- 3
- 4
- 5
- 6
- 7
- 8
- 9
- 10

BLUE-DRILL LINE 30
ZOLL / INCH

SETS / DISPLAYS: INHALT 20 1611
SETS / DISPLAYS: CONTENT 20 1611

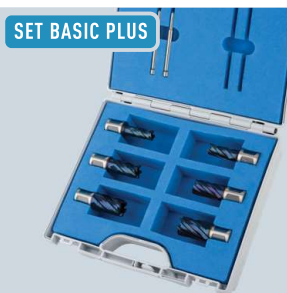
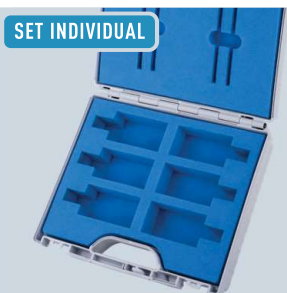
Lagerprogramm + Zubehör siehe Seite 478-479
Stock range + accessories see page 478-479

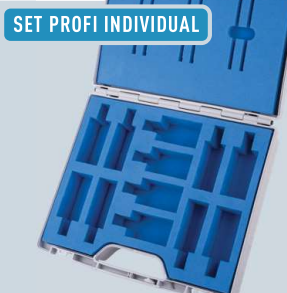
- 1
- 2
- 3
- 4
- 5
- 6
- 7
- 8
- 9
- 10

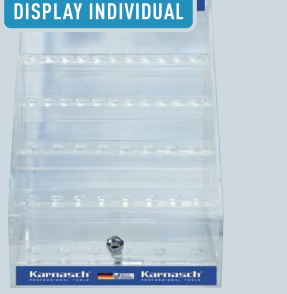
<p>6 Stück Pieces</p>	<p>SET BASIC</p>  <p>• 20 2101</p>	<p>SET BASIC PLUS</p>  <p>• 20 2102</p>	<p>SET INDIVIDUAL</p>  <p>• 20 1138</p>
	<p>Ø 2× 5/8", 2× 13/16", 2× 9/16" 2× Auswerferstifte / Ejector pins Die meistverkauften drei Abmessungen in einem Set The best selling three dimensions in a set</p>	<p>Ø 9/16", 5/8", 11/16", 3/4", 13/16", 7/8" 2× Auswerferstifte / Ejector pins Die BESTSELLER bis Ø 7/8" BESTSELLER up to Ø 7/8"</p>	<p>Leer für max. 6 Kernbohrer + 4 Auswerferstifte. Max. Ø 40 mm möglich. Gerne stellen wir auch Ihr Wunschset zusammen. Empty for max. 6 annular cutters + 4 ejector pins. Maximum possible Ø 40 mm. We also compile your desired set on request.</p>
<p>12 Stück Pieces</p>	<p>SET PROFI</p>  <p>• 20 2103</p>	<p>SET PROFI PLUS</p>  <p>• 20 2104</p>	<p>SET PROFI INDIVIDUAL</p>  <p>• 20 1132</p>
	<p>Ø 4× 5/8", 4× 13/16", 4× 9/16" 2× Auswerferstifte / Ejector pins Die meistverkauften drei Abmessungen in einem Set The best selling three dimensions in a set</p>	<p>Ø 2× 9/16", 2× 5/8", 2× 11/16", 2× 3/4", 2× 13/16", 2× 7/8" 2× Auswerferstifte / Ejector pins Die BESTSELLER bis Ø 7/8" BESTSELLER up to Ø 7/8"</p>	<p>Leer für max. 12 Kernbohrer + 4 Auswerferstifte. Max. Ø 40 mm möglich. Gerne stellen wir auch Ihr Wunschset zusammen. Empty for max. 12 annular cutters + 4 ejector pins. Maximum possible Ø 40 mm. We also compile your desired set on request.</p>
<p>≤ 50 Stück Pieces</p>			<p>SET DELUXE INDIVIDUAL</p>  <p>• 20 1139</p>
			<p>Leer für max. 50 Kernbohrer bis Ø 120 mm möglich. Anzahl der Auswerferstifte nach Wunsch. Gerne stellen wir auch Ihr Wunschset zusammen. Empty for max. 50 annular cutters. Maximum possible Ø 120 mm. Quantity ejector pins on request. We also compile your desired set on request.</p>
<p>44 Stück Pieces</p>	<p>Abschließbares Acryldisplay Ideal als Showcase und Mini-Lager. Alle gängigen Abmessungen sofort sichtbar und griffbereit.</p> <p>Lockable acrylic display Ideal as showcase and small warehouse. All current sizes directly visible and available.</p>		<p>DISPLAY INDIVIDUAL</p>  <p>• 20 1344</p>
			<p>Leer für max. 44 Kernbohrer bis Ø 60 mm möglich. Anzahl der Auswerferstifte nach Wunsch. Gerne stellen wir auch Ihr Wunschset zusammen. Empty for max. 44 annular cutters. Maximum possible Ø 60 mm. Quantity ejector pins on request. We also compile your desired set on request.</p>

6 Stück Pieces

SET BASIC • 20 1987

Ø 2×14, 2×18, 2×22 mm
2× Auswerferstifte / Ejector pins
Die meistverkauften drei Abmessungen in einem Set
The best selling three dimensions in a set

SET BASIC PLUS • 20 1324

Ø 12, 14, 16, 18, 20, 22 mm
2× Auswerferstifte / Ejector pins
Die BESTSELLER bis Ø 22 mm
BESTSELLER up to Ø 22 mm

SET INDIVIDUAL • 20 1138

Leer für max. 6 Kernbohrer + 4 Auswerferstifte.
Max. Ø 40 mm möglich. Gerne stellen wir auch Ihr Wunschset zusammen.
Empty for max. 6 annular cutters + 4 ejector pins.
Maximum possible Ø 40 mm. We also compile your desired set on request.

12 Stück Pieces

SET PROFI • 20 1988

Ø 4×14, 4×18, 4×22 mm
2× Auswerferstifte / Ejector pins
Die meistverkauften drei Abmessungen in einem Set
The best selling three dimensions in a set

SET PROFI PLUS • 20 1989

Ø 2×12, 2×14, 2×16, 2×18, 2×20, 2×22 mm
2× Auswerferstifte / Ejector pins
Die BESTSELLER bis Ø 22 mm
BESTSELLER up to Ø 22 mm

SET PROFI INDIVIDUAL • 20 1132

Leer für max. 12 Kernbohrer + 4 Auswerferstifte.
Max. Ø 40 mm möglich. Gerne stellen wir auch Ihr Wunschset zusammen.
Empty for max. 12 annular cutters + 4 ejector pins.
Maximum possible Ø 40 mm. We also compile your desired set on request.

≤ 50 Stück Pieces

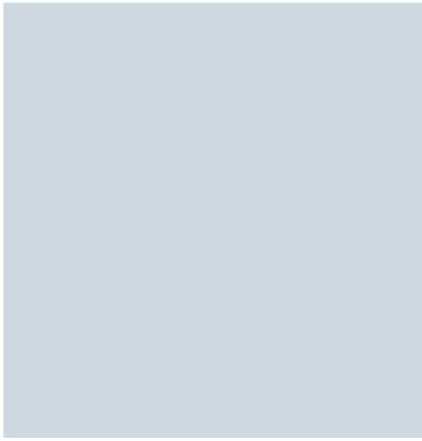
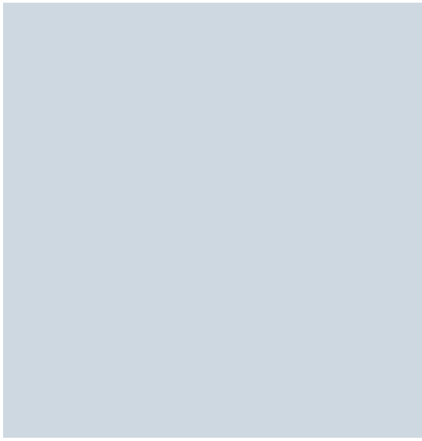

SET DELUXE INDIVIDUAL • 20 1139

Leer für max. 50 Kernbohrer bis Ø 120 mm möglich.
Anzahl der Auswerferstifte nach Wunsch. Gerne stellen wir auch Ihr Wunschset zusammen.
Empty for max. 50 annular cutters. Maximum possible Ø 120 mm. Quantity ejector pins on request. We also compile your desired set on request.

44 Stück Pieces

Abschließbares Acryldisplay
Ideal als Showcase und Mini-Lager. Alle gängigen Abmessungen sofort sichtbar und griffbereit.

Lockable acrylic display
Ideal as showcase and small warehouse. All current sizes directly visible and available.

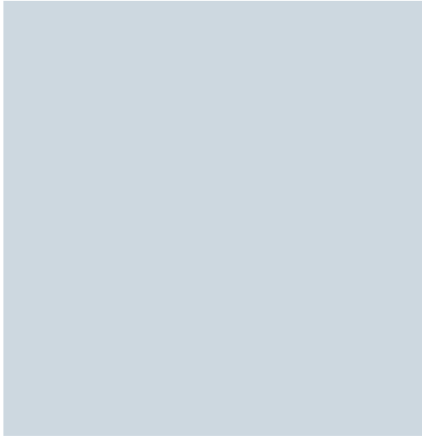

DISPLAY INDIVIDUAL • 20 1344

Leer für max. 44 Kernbohrer bis Ø 60 mm möglich.
Anzahl der Auswerferstifte nach Wunsch. Gerne stellen wir auch Ihr Wunschset zusammen.
Empty for max. 44 annular cutters. Maximum possible Ø 60 mm. Quantity ejector pins on request. We also compile your desired set on request.













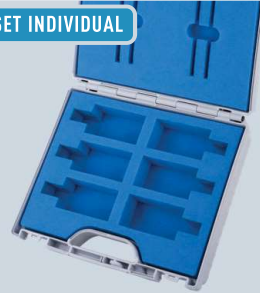

- 1
- 2
- 3
- 4
- 5
- 6
- 7
- 8
- 9
- 10

GOLD-DRILL LINE 55

SETS / DISPLAYS: INHALT 20 1270N
SETS / DISPLAYS: CONTENT 20 1270N

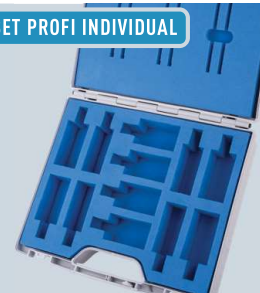
Lagerprogramm + Zubehör siehe Seite 488-489
Stock range + accessories see page 488-489

- 1 
- 2 
- 3 
- 4 
- 5 
- 6 
- 7 
- 8 
- 9 
- 10 

<p>6 Stück Pieces</p>	<p>SET BASIC • 20 1990 </p>  <p>Ø 2×14, 2×18, 2×22 mm 2× Auswerferstifte / Ejector pins Die meistverkauften drei Abmessungen in einem Set The best selling three dimensions in a set</p>	<p>SET BASIC PLUS • 20 1326 </p>  <p>Ø 12, 14, 16, 18, 22, 26 mm 2× Auswerferstifte / Ejector pins Die BESTSELLER bis Ø 26 mm BESTSELLER up to Ø 26 mm</p>	<p>SET INDIVIDUAL • 20 1138 </p>  <p>Leer für max. 6 Kernbohrer + 4 Auswerferstifte. Max. Ø 40 mm möglich. Gerne stellen wir auch Ihr Wunschset zusammen. Empty for max. 6 annular cutters + 4 ejector pins. Maximum possible Ø 40 mm. We also compile your desired set on request.</p>
<p>12 Stück Pieces</p>	<p>SET PROFI • 20 1991 </p>  <p>Ø 4×14, 4×18, 4×22 mm 2× Auswerferstifte / Ejector pins Die meistverkauften drei Abmessungen in einem Set The best selling three dimensions in a set</p>	<p>SET PROFI PLUS • 20 1992 </p>  <p>Ø 2×12, 2×14, 2×16, 2×18, 2×22, 2×26 mm 2× Auswerferstifte / Ejector pins Die BESTSELLER bis Ø 26 mm BESTSELLER up to Ø 26 mm</p>	<p>SET PROFI INDIVIDUAL • 20 1132 </p>  <p>Leer für max. 12 Kernbohrer + 4 Auswerferstifte. Max. Ø 40 mm möglich. Gerne stellen wir auch Ihr Wunschset zusammen. Empty for max. 12 annular cutters + 4 ejector pins. Maximum possible Ø 40 mm. We also compile your desired set on request.</p>
<p>≤ 50 Stück Pieces</p>			<p>SET DELUXE INDIVIDUAL • 20 1139 </p>  <p>Leer für max. 50 Kernbohrer bis Ø 120 mm möglich. Anzahl der Auswerferstifte nach Wunsch. Gerne stellen wir auch Ihr Wunschset zusammen. Empty for max. 50 annular cutters. Maximum possible Ø 120 mm. Quantity ejector pins on request. We also compile your desired set on request.</p>
<p>44 Stück Pieces</p>	<p>Abschließbares Acryldisplay Ideal als Showcase und Mini-Lager. Alle gängigen Abmessungen sofort sichtbar und griffbereit.</p> <p>Lockable acrylic display Ideal as showcase and small warehouse. All current sizes directly visible and available.</p>		<p>DISPLAY INDIVIDUAL • 20 1344 </p>  <p>Leer für max. 44 Kernbohrer bis Ø 60 mm möglich. Anzahl der Auswerferstifte nach Wunsch. Gerne stellen wir auch Ihr Wunschset zusammen. Empty for max. 44 annular cutters. Maximum possible Ø 60 mm. Quantity ejector pins on request. We also compile your desired set on request.</p>

GOLD-DRILL LINE 30
ZOLL / INCH

SETS / DISPLAYS: INHALT 20 1610
SETS / DISPLAYS: CONTENT 20 1610

Lagerprogramm + Zubehör siehe Seite 494-495
Stock range + accessories see page 494-495

6
Stück
Pieces

SET BASIC • 20 1981

Ø 2× 5/8", 2× 13/16", 2× 9/16"
2× Auswerferstifte / Ejector pins
Die meistverkauften drei Abmessungen in einem Set
The best selling three dimensions in a set

SET BASIC PLUS • 20 1476

Ø 9/16", 5/8", 11/16", 3/4", 13/16", 7/8"
2× Auswerferstifte / Ejector pins
Die BESTSELLER bis Ø 7/8"
BESTSELLER up to Ø 7/8"

SET INDIVIDUAL • 20 1138

Leer für max. 6 Kernbohrer + 4 Auswerferstifte.
Max. Ø 40 mm möglich. Gerne stellen wir auch Ihr Wunschset zusammen.
Empty for max. 6 annular cutters + 4 ejector pins.
Maximum possible Ø 40 mm. We also compile your desired set on request.

12
Stück
Pieces

SET PROFI • 20 1982

Ø 4× 5/8", 4× 13/16", 4× 9/16"
2× Auswerferstifte / Ejector pins
Die meistverkauften drei Abmessungen in einem Set
The best selling three dimensions in a set

SET PROFI PLUS • 20 1983

Ø 2× 9/16", 2× 5/8", 2× 11/16", 2× 3/4", 2× 13/16", 2× 7/8"
2× Auswerferstifte / Ejector pins
Die BESTSELLER bis Ø 7/8"
BESTSELLER up to Ø 7/8"

SET PROFI INDIVIDUAL • 20 1132

Leer für max. 12 Kernbohrer + 4 Auswerferstifte.
Max. Ø 40 mm möglich. Gerne stellen wir auch Ihr Wunschset zusammen.
Empty for max. 12 annular cutters + 4 ejector pins.
Maximum possible Ø 40 mm. We also compile your desired set on request.

≤ 50
Stück
Pieces

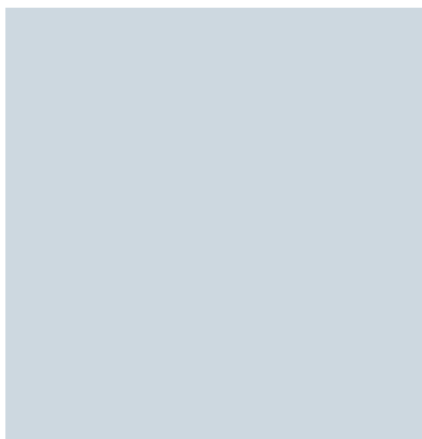
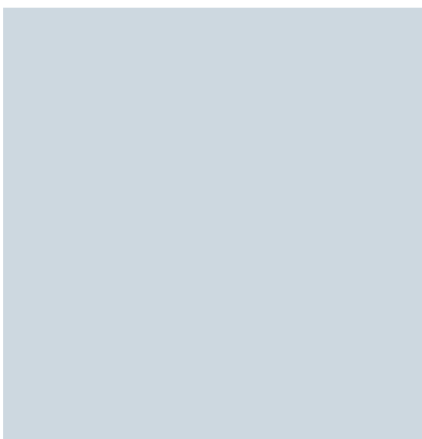

SET DELUXE INDIVIDUAL • 20 1139

Leer für max. 50 Kernbohrer bis Ø 120 mm möglich.
Anzahl der Auswerferstifte nach Wunsch. Gerne stellen wir auch Ihr Wunschset zusammen.
Empty for max. 50 annular cutters. Maximum possible Ø 120 mm. Quantity ejector pins on request. We also compile your desired set on request.

44
Stück
Pieces

Abschließbares Acryldisplay
Ideal als Showcase und Mini-Lager. Alle gängigen Abmessungen sofort sichtbar und griffbereit.

Lockable acrylic display
Ideal as showcase and small warehouse. All current sizes directly visible and available.

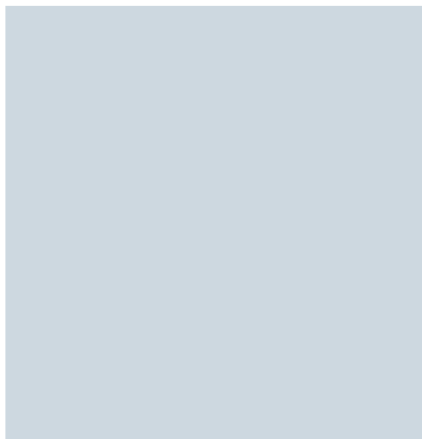

DISPLAY INDIVIDUAL • 20 1344

Leer für max. 44 Kernbohrer bis Ø 60 mm möglich.
Anzahl der Auswerferstifte nach Wunsch. Gerne stellen wir auch Ihr Wunschset zusammen.
Empty for max. 44 annular cutters. Maximum possible Ø 60 mm. Quantity ejector pins on request. We also compile your desired set on request.

- 1
- 2
- 3
- 4
- 5
- 6
- 7
- 8
- 9
- 10

GOLD-DRILL LINE 55
ZOLL / INCH

SETS / DISPLAYS: INHALT 20 1620
SETS / DISPLAYS: CONTENT 20 1620

Lagerprogramm + Zubehör siehe Seite 496-497
Stock range + accessories see page 496-497

- 1
- 2
- 3
- 4
- 5
- 6
- 7
- 8
- 9
- 10

6 Stück Pieces

SET BASIC • 20 1984

Ø 2× 5/8", 2× 11/16", 2× 13/16"
2× Auswerferstifte / Ejector pins
Die meistverkauften drei Abmessungen in einem Set
The best selling three dimensions in a set

SET BASIC PLUS • 20 1477

Ø 9/16", 5/8", 11/16", 3/4", 13/16", 7/8"
2× Auswerferstifte / Ejector pins
Die BESTSELLER bis Ø 7/8"
BESTSELLER up to Ø 7/8"

SET INDIVIDUAL • 20 1138

Leer für max. 6 Kernbohrer + 4 Auswerferstifte.
Max. Ø 40 mm möglich. Gerne stellen wir auch Ihr Wunschset zusammen.
Empty for max. 6 annular cutters + 4 ejector pins.
Maximum possible Ø 40 mm. We also compile your desired set on request.

12 Stück Pieces

SET PROFI • 20 1985

Ø 3× 5/8", 3× 11/16", 3× 13/16", 3× 7/8"
2× Auswerferstifte / Ejector pins
Die meistverkauften vier Abmessungen in einem Set
The best selling four dimensions in a set

SET PROFI PLUS • 20 1986

Ø 2× 9/16", 2× 5/8", 2× 11/16", 2× 3/4", 2× 13/16", 2× 7/8"
2× Auswerferstifte / Ejector pins
Die BESTSELLER bis Ø 7/8"
BESTSELLER up to Ø 7/8"

SET PROFI INDIVIDUAL • 20 1132

Leer für max. 12 Kernbohrer + 4 Auswerferstifte.
Max. Ø 40 mm möglich. Gerne stellen wir auch Ihr Wunschset zusammen.
Empty for max. 12 annular cutters + 4 ejector pins.
Maximum possible Ø 40 mm. We also compile your desired set on request.

≤ 50 Stück Pieces

SET DELUXE INDIVIDUAL • 20 1139

Leer für max. 50 Kernbohrer bis Ø 120 mm möglich.
Anzahl der Auswerferstifte nach Wunsch. Gerne stellen wir auch Ihr Wunschset zusammen.
Empty for max. 50 annular cutters. Maximum possible Ø 120 mm. Quantity ejector pins on request. We also compile your desired set on request.

44 Stück Pieces

Abschließbares Acryldisplay
Ideal als Showcase und Mini-Lager. Alle gängigen Abmessungen sofort sichtbar und griffbereit.

Lockable acrylic display
Ideal as showcase and small warehouse. All current sizes directly visible and available.

DISPLAY INDIVIDUAL • 20 1344

Leer für max. 44 Kernbohrer bis Ø 60 mm möglich.
Anzahl der Auswerferstifte nach Wunsch. Gerne stellen wir auch Ihr Wunschset zusammen.
Empty for max. 44 annular cutters. Maximum possible Ø 60 mm. Quantity ejector pins on request. We also compile your desired set on request.

HARD-LINE 40

SETS / DISPLAYS: INHALT 20 1147
SETS / DISPLAYS: CONTENT 20 1147

Lagerprogramm + Zubehör siehe Seite 510
Stock range + accessories see page 510

6
Stück
Pieces

SET BASIC • 20 1933

Ø 2×14, 2×18, 2×22 mm
2× Auswerferstifte / Ejector pins
Die meistverkauften drei Abmessungen in einem Set
The best selling three dimensions in a set

SET BASIC PLUS • 20 1337

Ø 14, 16, 18, 20, 22, 26 mm
2× Auswerferstifte / Ejector pins
Die BESTSELLER bis Ø 26 mm
BESTSELLER up to Ø 26 mm

SET INDIVIDUAL • 20 1138

Leer für max. 6 Kernbohrer + 4 Auswerferstifte.
Max. Ø 40 mm möglich. Gerne stellen wir auch Ihr Wunschset zusammen.
Empty for max. 6 annular cutters + 4 ejector pins.
Maximum possible Ø 40 mm. We also compile your desired set on request.

12
Stück
Pieces

SET PROFI • 20 1934

Ø 4×14, 4×18, 4×22 mm
2× Auswerferstifte / Ejector pins
Die meistverkauften drei Abmessungen in einem Set
The best selling three dimensions in a set

SET PROFI PLUS • 20 1935

Ø 2×14, 2×16, 2×18, 2×20, 2×22, 2×26 mm
2× Auswerferstifte / Ejector pins
Die BESTSELLER bis Ø 26 mm
BESTSELLER up to Ø 26 mm

SET PROFI INDIVIDUAL • 20 1132

Leer für max. 12 Kernbohrer + 4 Auswerferstifte.
Max. Ø 40 mm möglich. Gerne stellen wir auch Ihr Wunschset zusammen.
Empty for max. 12 annular cutters + 4 ejector pins.
Maximum possible Ø 40 mm. We also compile your desired set on request.

≤ 50
Stück
Pieces

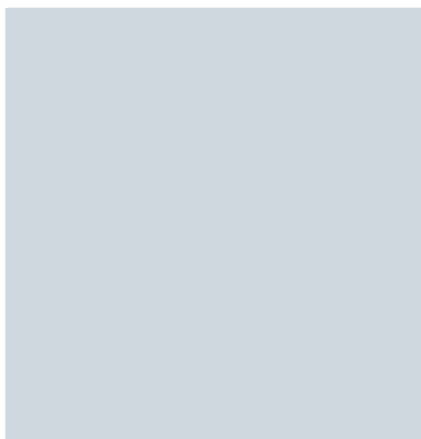
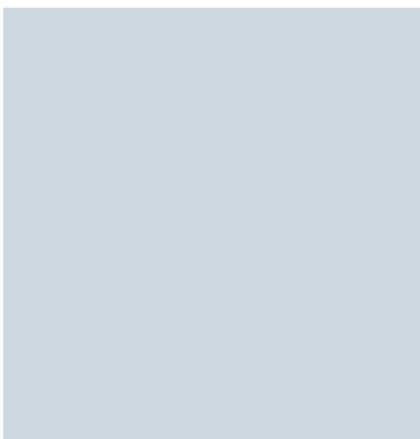

SET DELUXE INDIVIDUAL • 20 1139

Leer für max. 50 Kernbohrer bis Ø 120 mm möglich.
Anzahl der Auswerferstifte nach Wunsch. Gerne stellen wir auch Ihr Wunschset zusammen.
Empty for max. 50 annular cutters. Maximum possible Ø 120 mm. Quantity ejector pins on request. We also compile your desired set on request.

44
Stück
Pieces

Abschließbares Acryldisplay
Ideal als Showcase und Mini-Lager. Alle gängigen Abmessungen sofort sichtbar und griffbereit.

Lockable acrylic display
Ideal as showcase and small warehouse. All current sizes directly visible and available.

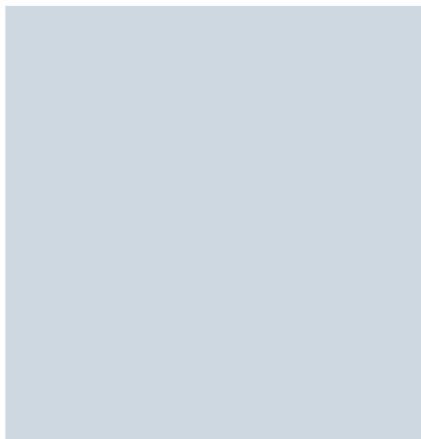

DISPLAY INDIVIDUAL • 20 1344

Leer für max. 44 Kernbohrer bis Ø 60 mm möglich.
Anzahl der Auswerferstifte nach Wunsch. Gerne stellen wir auch Ihr Wunschset zusammen.
Empty for max. 44 annular cutters. Maximum possible Ø 60 mm. Quantity ejector pins on request. We also compile your desired set on request.

- 1
- 2
- 3
- 4
- 5
- 6
- 7
- 8
- 9
- 10

HARD-LINE 55

SETS / DISPLAYS: INHALT 20 1148
SETS / DISPLAYS: CONTENT 20 1148

Lagerprogramm + Zubehör siehe Seite 511
Stock range + accessories see page 511

- 1
- 2
- 3
- 4
- 5
- 6
- 7
- 8
- 9
- 10

6 Stück Pieces

SET BASIC • 20 1941

Ø 2x14, 2x18, 2x22 mm
2x Auswerferstifte / Ejector pins
Die meistverkauften drei Abmessungen in einem Set
The best selling three dimensions in a set

SET BASIC PLUS • 20 1354

Ø 12, 14, 18, 20, 22, 26 mm
2x Auswerferstifte / Ejector pins
Die BESTSELLER bis Ø 26 mm
BESTSELLER up to Ø 26 mm

SET INDIVIDUAL • 20 1138

Leer für max. 6 Kernbohrer + 4 Auswerferstifte.
Max. Ø 40 mm möglich. Gerne stellen wir auch Ihr Wunschset zusammen.
Empty for max. 6 annular cutters + 4 ejector pins.
Maximum possible Ø 40 mm. We also compile your desired set on request.

12 Stück Pieces

SET PROFI • 20 1942

Ø 4x14, 4x18, 4x22 mm
2x Auswerferstifte / Ejector pins
Die meistverkauften drei Abmessungen in einem Set
The best selling three dimensions in a set

SET PROFI PLUS • 20 1943

Ø 2x12, 2x14, 2x18, 2x20, 2x22, 2x26 mm
2x Auswerferstifte / Ejector pins
Die BESTSELLER bis Ø 26 mm
BESTSELLER up to Ø 26 mm

SET PROFI INDIVIDUAL • 20 1132

Leer für max. 12 Kernbohrer + 4 Auswerferstifte.
Max. Ø 40 mm möglich. Gerne stellen wir auch Ihr Wunschset zusammen.
Empty for max. 12 annular cutters + 4 ejector pins.
Maximum possible Ø 40 mm. We also compile your desired set on request.

≤ 50 Stück Pieces

SET DELUXE INDIVIDUAL • 20 1139

Leer für max. 50 Kernbohrer bis Ø 120 mm möglich.
Anzahl der Auswerferstifte nach Wunsch. Gerne stellen wir auch Ihr Wunschset zusammen.
Empty for max. 50 annular cutters. Maximum possible Ø 120 mm. Quantity ejector pins on request. We also compile your desired set on request.

44 Stück Pieces

Abschließbares Acryldisplay
Ideal als Showcase und Mini-Lager. Alle gängigen Abmessungen sofort sichtbar und griffbereit.

Lockable acrylic display
Ideal as showcase and small warehouse. All current sizes directly visible and available.

DISPLAY INDIVIDUAL • 20 1344

Leer für max. 44 Kernbohrer bis Ø 60 mm möglich.
Anzahl der Auswerferstifte nach Wunsch. Gerne stellen wir auch Ihr Wunschset zusammen.
Empty for max. 44 annular cutters. Maximum possible Ø 60 mm. Quantity ejector pins on request. We also compile your desired set on request.

BLUE-DRILL LINE / 40

SETS / DISPLAYS: INHALT 20 1146
SETS / DISPLAYS: CONTENT 20 1146

Lagerprogramm + Zubehör siehe Seite 516
Stock range + accessories see page 516

6 Stück Pieces

SET BASIC • 20 1964

Ø 2×14, 2×18, 2×22 mm
2× Auswerferstifte / Ejector pins
Die meistverkauften drei Abmessungen in einem Set
The best selling three dimensions in a set

SET BASIC PLUS • 20 1333

Ø 14, 16, 18, 20, 22, 26 mm
2× Auswerferstifte / Ejector pins
Die BESTSELLER bis Ø 26 mm
BESTSELLER up to Ø 26 mm

SET INDIVIDUAL • 20 1138

Leer für max. 6 Kernbohrer + 4 Auswerferstifte.
Max. Ø 40 mm möglich. Gerne stellen wir auch Ihr Wunschset zusammen.
Empty für max. 6 annular cutters + 4 ejector pins.
Maximum possible Ø 40 mm. We also compile your desired set on request.

12 Stück Pieces

SET PROFI • 20 1965

Ø 3×14, 3×18, 3×20, 3×22 mm
2× Auswerferstifte / Ejector pins
Die meistverkauften vier Abmessungen in einem Set
The best selling four dimensions in a set

SET PROFI PLUS • 20 1966

Ø 2×14, 2×16, 2×18, 2×20, 2×22, 2×26 mm
2× Auswerferstifte / Ejector pins
Die BESTSELLER bis Ø 26 mm
BESTSELLER up to Ø 26 mm

SET PROFI INDIVIDUAL • 20 1132

Leer für max. 12 Kernbohrer + 4 Auswerferstifte.
Max. Ø 40 mm möglich. Gerne stellen wir auch Ihr Wunschset zusammen.
Empty für max. 12 annular cutters + 4 ejector pins.
Maximum possible Ø 40 mm. We also compile your desired set on request.

≤ 50 Stück Pieces

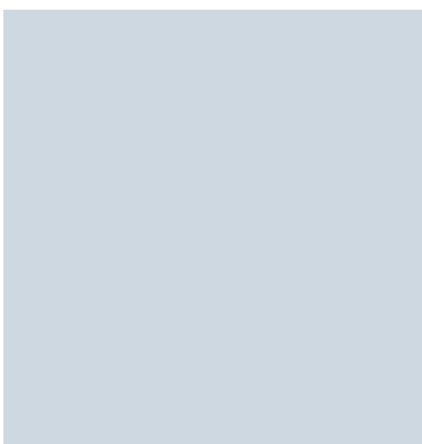
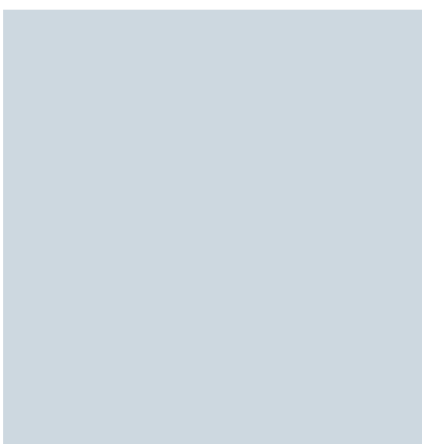

SET DELUXE INDIVIDUAL • 20 1139

Leer für max. 50 Kernbohrer bis Ø 120 mm möglich.
Anzahl der Auswerferstifte nach Wunsch. Gerne stellen wir auch Ihr Wunschset zusammen.
Empty für max. 50 annular cutters. Maximum possible Ø 120 mm. Quantity ejector pins on request. We also compile your desired set on request.

44 Stück Pieces

Abschließbares Acryldisplay
Ideal als Showcase und Mini-Lager. Alle gängigen Abmessungen sofort sichtbar und griffbereit.

Lockable acrylic display
Ideal as showcase and small warehouse. All current sizes directly visible and available.

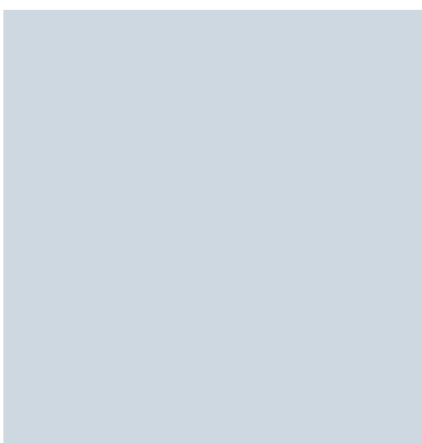

DISPLAY INDIVIDUAL • 20 1344









Leer für max. 44 Kernbohrer bis Ø 60 mm möglich.
Anzahl der Auswerferstifte nach Wunsch. Gerne stellen wir auch Ihr Wunschset zusammen.
Empty für max. 44 annular cutters. Maximum possible Ø 60 mm. Quantity ejector pins on request. We also compile your desired set on request.

- 1
- 2
- 3
- 4
- 5
- 6
- 7
- 8
- 9
- 10

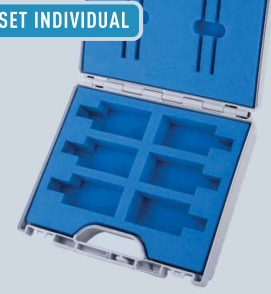
GOLD-DRILL LINE 40 SETS / DISPLAYS: INHALT 20 1146U
SETS / DISPLAYS: CONTENT 20 1146U

Lagerprogramm + Zubehör siehe Seite 520
Stock range + accessories see page 520

- 1
- 2
- 3
- 4
- 5
- 6
- 7
- 8
- 9
- 10

<p>6 Stück Pieces</p>	<p>SET BASIC • 20 1999 </p>  <p>Ø 2×14, 2×18, 2×22 mm 2× Auswerferstifte / Ejector pins Die meistverkauften drei Abmessungen in einem Set The best selling three dimensions in a set</p>	<p>SET BASIC PLUS • 20 1335 </p>  <p>Ø 12, 14, 16, 18, 20, 22 mm 2× Auswerferstifte / Ejector pins Die BESTSELLER bis Ø 22 mm BESTSELLER up to Ø 22 mm</p>	<p>SET INDIVIDUAL • 20 1138 </p>  <p>Leer für max. 6 Kernbohrer + 4 Auswerferstifte. Max. Ø 40 mm möglich. Gerne stellen wir auch Ihr Wunschset zusammen. Empty for max. 6 annular cutters + 4 ejector pins. Maximum possible Ø 40 mm. We also compile your desired set on request.</p>
<p>12 Stück Pieces</p>	<p>SET PROFI • 20 2001 </p>  <p>Ø 4×14, 4×18, 4×22 mm 2× Auswerferstifte / Ejector pins Die meistverkauften drei Abmessungen in einem Set The best selling three dimensions in a set</p>	<p>SET PROFI PLUS • 20 2002 </p>  <p>Ø 2×12, 2×14, 2×16, 2×18, 2×20, 2×22 mm 2× Auswerferstifte / Ejector pins Die BESTSELLER bis Ø 22 mm BESTSELLER up to Ø 22 mm</p>	<p>SET PROFI INDIVIDUAL • 20 1132 </p>  <p>Leer für max. 12 Kernbohrer + 4 Auswerferstifte. Max. Ø 40 mm möglich. Gerne stellen wir auch Ihr Wunschset zusammen. Empty for max. 12 annular cutters + 4 ejector pins. Maximum possible Ø 40 mm. We also compile your desired set on request.</p>
<p>≤ 50 Stück Pieces</p>			<p>SET DELUXE INDIVIDUAL • 20 1139 </p>  <p>Leer für max. 50 Kernbohrer bis Ø 120 mm möglich. Anzahl der Auswerferstifte nach Wunsch. Gerne stellen wir auch Ihr Wunschset zusammen. Empty for max. 50 annular cutters. Maximum possible Ø 120 mm. Quantity ejector pins on request. We also compile your desired set on request.</p>
<p>44 Stück Pieces</p>	<p>Abschließbares Acryldisplay Ideal als Showcase und Mini-Lager. Alle gängigen Abmessungen sofort sichtbar und griffbereit.</p> <p>Lockable acrylic display Ideal as showcase and small warehouse. All current sizes directly visible and available.</p>		<p>DISPLAY INDIVIDUAL • 20 1344 </p>  <p>Leer für max. 44 Kernbohrer bis Ø 60 mm möglich. Anzahl der Auswerferstifte nach Wunsch. Gerne stellen wir auch Ihr Wunschset zusammen. Empty for max. 44 annular cutters. Maximum possible Ø 60 mm. Quantity ejector pins on request. We also compile your desired set on request.</p>